

Find	Item	Description	QTY - 12V ARFS-500520-90	QTY - 24V ARFS-500530-90
1	CNF-FF-500501-PA CNF-FF-500502-PA	RAPID FOAM FILL PUMP ASSEMBLY - 12V RAPID FOAM FILL PUMP ASSEMBLY - 24V	1 -	- 1
2	CNF-FF-500502-HA CNF-FF-500503-HA	RAPID FOAM FILL HARNESS ASSEMBLY - 12V RAPID FOAM FILL HARNESS ASSEMBLY - 24V	1 -	- 1
3	CNF-FF-500503-PT CNF-FF-500506-HD	RAPID FOAM FILL PICK-UP TUBE ASSEMBLY RAPID FOAM FILL HARDWARE KIT	1	1
4	** BA-3412	BULKHEAD ADAPTER 3/4" MGH x 1/2" FNPT	1	1
5	** AD-1212	ADAPTER 1/2" MNPT x 1/2" BARB BLK POLY	1	1
6	** TE-500	TEE 1/2" MNPT BLK POLY	1	1
7	** WGC-500	CLAMP WEAR GEAR 1/2"-7/8"	6	6
8	** CP-500	CAP 3/4" GH BRASS W/ORING	1	1
9	** EL-500	ELBOW 90 DEG 1/2" NPT	2	2
10	CNF-FF-500507-LA	RAPID FOAM FILL LEVEL SENSOR ASSY	1	1
11	500-PVC-90	PICK UP TUBE, ARFS (90" 500-PVC) *	1	1
12	ARFS-FFLABEL	LABEL	1	1
13	832-SHCSSS	SOCKET HEAD CAP SCREW #8-32 x 2"	4	4
14	832-HNSS	HEX NUT #8-32	4	4
15	08-FWSS	FLAT WASHER #8	8	8
16	08-LWSS	LOCK WASHER #8	4	4
17	1024-BHCSSS	BUTTON HEAD CAP SCREW #10-24 x 3/4"	2	2
18	1024-HNSS	HEX NUT #10-24	2	2
19	10-LWSS	LOCK WASHER #10	2	2

\* LENGTH IS CUSTOMER DRIVEN. STANDARD LENGTH IS 90".  
 \*\* FIND 4,5,6,7,8,9 ARE IN THE CNF-FF-500506-HD HARDWARE KIT.

PHONE: 330.264.5678 or 800.228.1161 | FAX: 330.264.2944 or 800.531.7335 | www.akronbrass.com

WARRANTY AND DISCLAIMER\*: We warrant Akron Brass products for a period of five (5) years\* after purchase against defects in materials or workmanship. Akron Brass will repair or replace product which fails to satisfy this warranty. Repair or replacement shall be at the discretion of Akron Brass. Products must be promptly returned to Akron Brass for warranty service. We will not be responsible for: wear and tear; any improper installation, use, maintenance or storage; negligence of the owner or user; repair or modification after delivery; failure to follow our instructions or recommendations; or anything else beyond our control. WE MAKE NO WARRANTIES, EXPRESS OR IMPLIED, OTHER THAN THOSE INCLUDED IN THIS WARRANTY STATEMENT, AND WE DISCLAIM ANY IMPLIED WARRANTY OF MERCHANTABILITY OR FITNESS FOR ANY PARTICULAR PURPOSE. Further, we will not be responsible for any consequential, incidental or indirect damages (including, but not limited to, any loss of profits) from any cause whatsoever. No person has authority to change this warranty. \*Unless otherwise provided herein. Akron Brass industrial electronic components & the Severe-Duty Monitor have a one (1) year warranty. Select Akron Brass handline nozzles and valves carry a ten (10) year warranty. Scene Star Lights carry a (6) year warranty. Weldon products have a two (2) year warranty from date of manufacture (excluding consumable components). Select Weldon LED products carry a five (5) year warranty. Honda products have the manufacturers' warranty and Akron Brass disclaims any warranty in respect of those products.  
 ©Premier Farnell Corporation. 2012 All rights reserved. No portion of this can be reproduced without the express written consent of Premier Farnell Corporation

Parts List Sheet:  
**ARFS-RAPID FILL**  
 ARFS

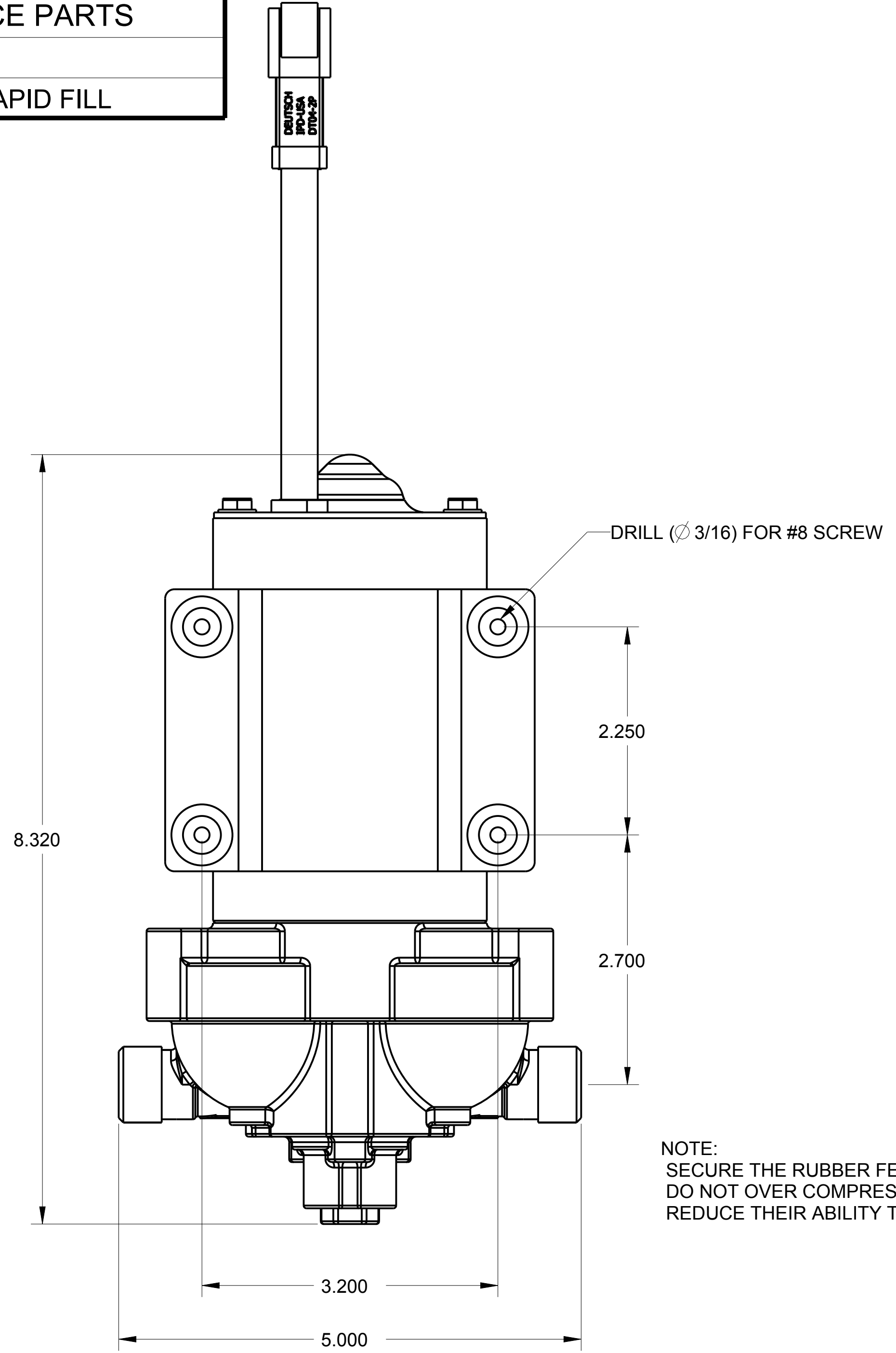
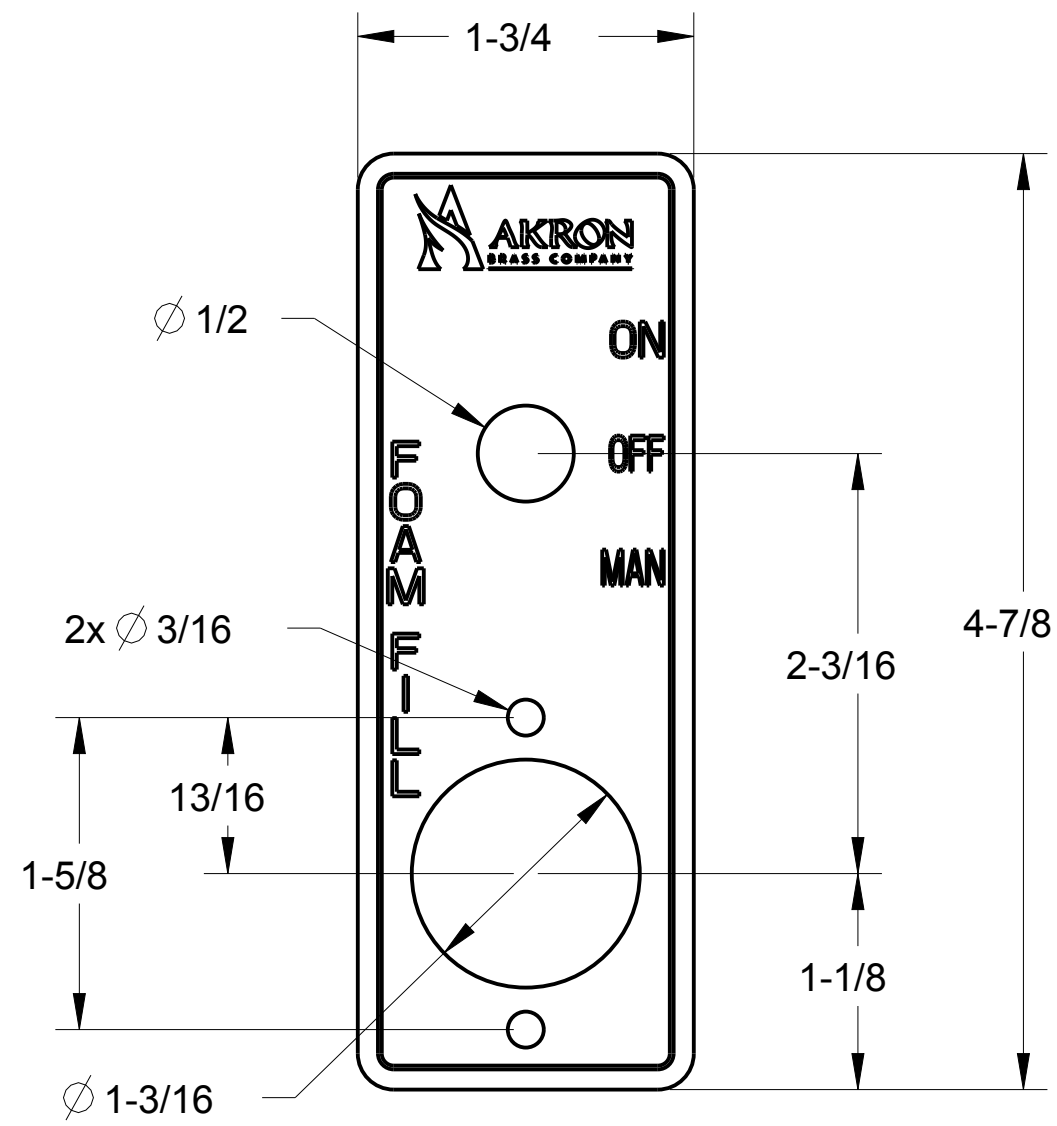

NOTE:  
 SECURE THE RUBBER FEET WITH #8 HARDWARE.  
 DO NOT OVER COMPRESS THE FEET: DOING SO WILL  
 REDUCE THEIR ABILITY TO ISOLATE VIBRATION/NOISE.

PHONE: 330.264.5678 or 800.228.1161 | FAX: 330.264.2944 or 800.531.7335 | [www.akronbrass.com](http://www.akronbrass.com)

WARRANTY AND DISCLAIMER\*: We warrant Akron Brass products for a period of five (5) years\* after purchase against defects in materials or workmanship. Akron Brass will repair or replace product which fails to satisfy this warranty. Repair or replacement shall be at the discretion of Akron Brass. Products must be promptly returned to Akron Brass for warranty service. We will not be responsible for: wear and tear; any improper installation, use, maintenance or storage; negligence of the owner or user; repair or modification after delivery; failure to follow our instructions or recommendations; or anything else beyond our control. WE MAKE NO WARRANTIES, EXPRESS OR IMPLIED, OTHER THAN THOSE INCLUDED IN THIS WARRANTY STATEMENT, AND WE DISCLAIM ANY IMPLIED WARRANTY OF MERCHANTABILITY OR FITNESS FOR ANY PARTICULAR PURPOSE. Further, we will not be responsible for any consequential, incidental or indirect damages (including, but not limited to, any loss of profits) from any cause whatsoever. No person has authority to change this warranty. \*Unless otherwise provided herein. Akron Brass industrial electronic components & the Severe-Duty Monitor have a one (1) year warranty. Select Akron Brass handline nozzles and valves carry a ten (10) year warranty. Scene Star Lights carry a (6) year warranty. Weldon products have a two (2) year warranty from date of manufacture (excluding consumable components). Select Weldon LED products carry a five (5) year warranty. Honda products have the manufacturers' warranty and Akron Brass disclaims any warranty in respect of those products.  
 ©Premier Farnell Corporation. 2012 All rights reserved. No portion of this can be reproduced without the express written consent of Premier Farnell Corporation

Parts List Sheet:  
**ARFS-RAPID FILL**