

DAYMAKER PARTS ASSY.

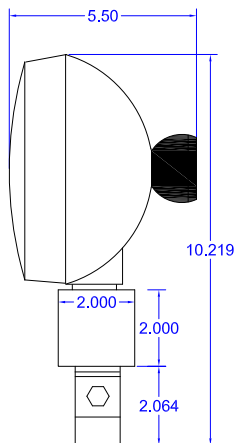
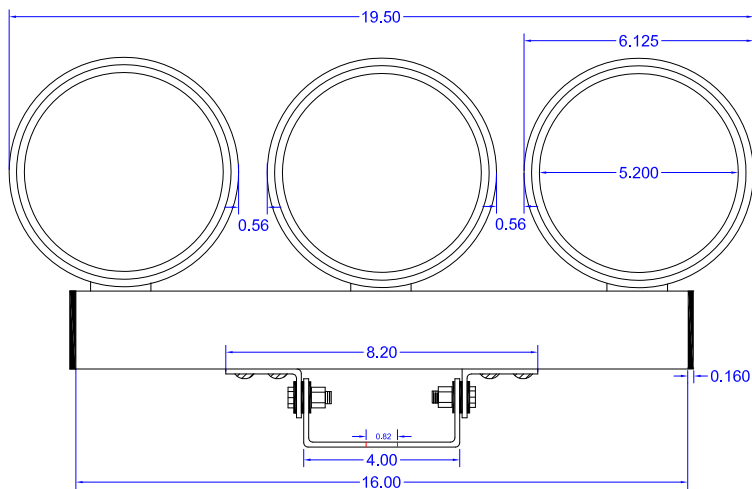
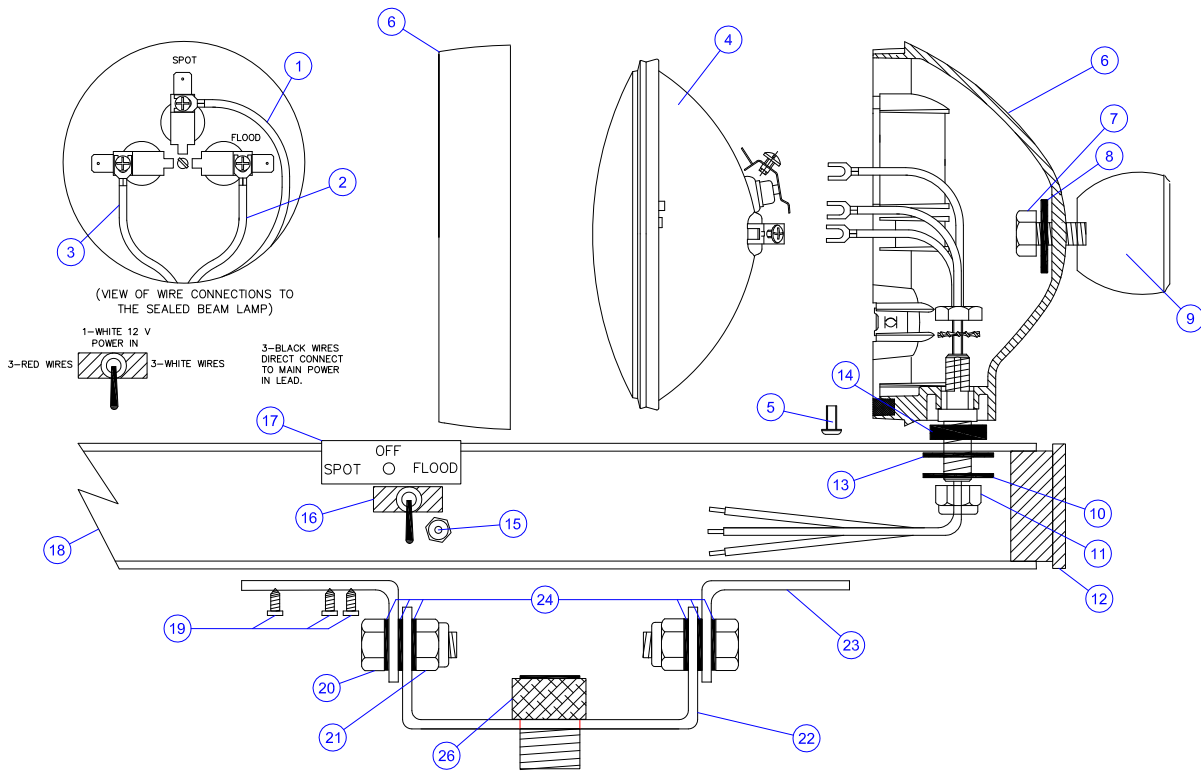

PARTS LIST

NO.	ASSY. NO.	PART NO.	DESCRIPTION	QTY.
1		435-WW	WHITE WIRE	3
2		436-RW	RED WIRE	3
3		437-BW	BLACK WIRE	3
4		4007	SEAL BEAM LAMP - STD	3
5		434-SS	SCREW	3
6		400-SA	6" CHROME SHELL ASSY.	3
7		402-BT	BOLT	3
8		403-FW	WASHER	3
9		401-KB	KNOB	3
10		403-FW	S.S. WASHER	3
11		416-LN	LOCK NUT	3
12		321-FP	CAP PLUG	2
13		414-NW	NYLON WASHER	3
14		413-NW	NYLON WASHER	3
15		345-SB	SWITCH BOOT	1
16		346-SW	SWITCH	1
17		412-DM	SWITCH DECAL	1
18		DM-BAR	2" ALUM. TUBE	1
19		411-SS	S.S. SELF TAPPING SCREW	6
20		409-BT	S.S. BOLT	2
21		410-LN	LOCK NUT	2
22		405-LB	LOWER BRACKET	1
23		406-UB	UPPER BRACKET	2
24		407-NW	NYLON WASHER	6

Zone	Chg.	Description	Date	Approved
01		REVISED PART#	8/18/06	

<p>AKRON A PREMIER FARNELL COMPANY WICKSTER, OHIO 44091 330 264-5678</p>	Designed By:	
	Drawn By:	CAF
	Appr'd By:	
	Plot Date:	8/18/06
Title: DAYMAKER HEAD Product(s): EXTENDA-LITE Style(s):		Drawing No. L-DAYMAKER
Supercedes:		
Scale:	NONE	Sheet(s): 1 OF 1