



# UV *SmartCAFS*

## Installation and Operation Manual



**HALE PRODUCTS, INC.**  
A Unit of IDEX Corporation  
607 NW 27<sup>th</sup> Ave  
Ocala, FL 34475  
United States



800-533-3569



800-520-3473



[www.haleproducts.com](http://www.haleproducts.com)  
[Halecustomerservice@idexcorp.com](mailto:Halecustomerservice@idexcorp.com)

FSG-MNL-00157  
REV F, January 2024

REVISION RECORD				
REV	Date	BY	Page	Description
A	28DEC2015	JDF	All	New Issue
B	24JAN2017	JJS	Drawings	Revised Drawing Update
C	21AUG2018	RAA	21, 22 86	Add pictures of gear pump w/ new motor driver Changed separator element replacement kit QTY from 1 to 2
D	13JUL2020	JS2	10 16 22 40-44 49 60 95-105 108-111	Added Dual Foam data Updated manifolds Updated dimensional diagrams Updated FSG-PL-01308 and FSG-PL-01422 Added multi-display setup/operation instructions Added Auto-Fill info, layout and components Updated wiring diagram, PL729, FSG-PL-01306, FSG-PL-01307 Added Air pressure limiter, dual bypass solenoids, coolant valve
E	22DEC2020	JS2	60-61	Added wiring details for autofill installation.
F	11JAN2024	JS2	105-106 114	Updated FSG-PL-01307 to latest Updated view for the 178-1050-10-0 Air manifold and provided new troubleshoot info in regards to the pressure limiter

**T.O.C.****Table of Contents**

<b>REVISION RECORD</b> .....	<b>2</b>
<b>T.O.C.</b> .....	<b>3</b>
<b>INTRODUCTION</b> .....	<b>7</b>
<b>ENVIRONMENTAL PROTECTION</b> .....	<b>7</b>
<b>SAFETY - RELEVANT DATA</b> .....	<b>8</b>
MAINTENANCE .....	8
TRAINING .....	8
NOISE .....	9
GAUGES .....	9
CLUTCH ENGAGEMENT .....	9
<b>GENERAL DATA</b> .....	<b>10</b>
COMPRESSOR .....	10
PUMP .....	10
COOLING SYSTEM.....	10
FOAM PROPORTIONING SYSTEM 3.3 - CLASS A AND B FOAM COMPATIBLE .....	10
FOAM PROPORTIONING SYSTEM 5.0 - CLASS A AND B FOAM COMPATIBLE .....	10
FOAM PROPORTIONING SYSTEM 6.5 - CLASS A AND B FOAM COMPATIBLE .....	10
FOAM PROPORTIONING SYSTEM DUAL 6.5 - CLASS A AND B FOAM COMPATIBLE .....	10
<b>LUBRICANTS</b> .....	<b>11</b>
COMPRESSOR SYSTEM .....	11
PUMP GEARBOX .....	11
CLUTCH HOUSING.....	11
<b>MAXIMUM INPUT RPM</b> .....	<b>11</b>
<b>MODEL IDENTIFICATION SYSTEM</b> .....	<b>12</b>
<b>RECOMMENDED FOAM AGENTS</b> .....	<b>13</b>
<b>MAJOR COMPONENTS AND CONTROLS</b> .....	<b>14</b>
GENERAL ARRANGEMENT.....	14
SMARTCAFS MIXING MANIFOLD.....	15
(A) VOLUTE STYLE PUMP.....	15
(B) HIGH PRESSURE .....	16
(C) STANDARD PRESSURE .....	16
FOAM UNIT 3.3, 5.0, 6.5 FOAM PUMP COMPONENT GROUP.....	17
CONTROL PANEL - SMARTCAFS .....	18
COMPONENT PANEL CUT-OUT DIMENSIONS .....	18
<b>SYSTEM OVERVIEW</b> .....	<b>19</b>
SAFETY INTERLOCKS ARE PROVIDED TO ENSURE THAT: .....	19
COMPRESSOR .....	19
OIL COOLER.....	19
SEPARATOR TANK .....	19
MANIFOLD .....	20
FOAM UNIT - FOAM PROPORTIONING SYSTEM.....	20

FOAM UNIT 3.3, 5.0, 6.5 SYSTEM – REMOTE MOUNTED ..... 21

FOAM UNIT DIMENSIONS ..... 22

**INSTALLATION AND INITIAL SET-UP ..... 24**

LIFTING POINTS ..... 24

STRAP LIFT POINTS ..... 24

**DRIVE LINE ..... 25**

PUMP CLEARANCE ..... 27

PANEL STRAINER ..... 28

COMPRESSOR CONNECTIONS ..... 29

COMPRESSOR OIL SERVICE ACCESS ..... 30

FLUID DRAIN POINTS ..... 31

WATER DRAIN – VOLUTE STYLE ..... 32

WATER DRAIN – Q-SERIES ..... 33

**SYSTEM OIL FILL ..... 34**

OIL FILLING POINTS ..... 34

ADDING OIL ..... 34

GEARBOX ..... 34

    GEARBOX OIL FILLING AND CHECKING ..... 34

OIL SEPARATOR TANK ..... 35

    SEPARATOR TANK FOR COMPRESSOR OIL ..... 36

HOT-SHIFT CLUTCH HOUSING ..... 37

    CLUTCH FLUID FILLING & CHECKING ..... 37

**SCHEMATICS ..... 38**

PLUMBING CONNECTIONS – DSD ..... 38

PLUMBING CONNECTIONS – Q-SERIES ..... 40

SMARTCAFS200 INTERCONNECTION DIAGRAM – DSD ..... 42

SMARTCAFS200 INTERCONNECTION DIAGRAM – Q-SERIES ..... 43

SMARTCAFS200 INTERCONNECTION DIAGRAM – ALL UNITS ..... 44

**FOAM TANK LOW LEVEL SENSOR ..... 45**

**ADDITIONAL INSTALLATION POINTS ..... 45**

FOAM TANK TO FOAM PUMP ..... 45

**VEHICLE DESIGN CONSIDERATIONS ..... 46**

**COMMISSIONING / START-UP PROCEDURE ..... 47**

OPTIONAL TANK SELECTION FOR FOAM UNIT 3.3/5.0/6.5 ..... 48

OPTIONAL MULTI-DISPLAY SETUP/OPERATION ..... 49

    (A) SETUP ..... 49

    (B) OPERATION ..... 50

**GENERAL OPERATION ..... 51**

PRESET SCREEN (START SCREEN) ..... 51

    (C) PRESET BUTTONS ..... 51

    (D) WATER FLOW DISPLAY ..... 52

    (E) HOME BUTTON ..... 52

    (F) MENU BUTTON ..... 52

OPERATING SCREEN ..... 52

    (G) WATER FLOW DISPLAY ..... 52

    (H) FOAM FLOW CAPACITY ..... 52

    (I) FOAM PERCENTAGE INDICATOR ..... 53

(J)	FOAM POWER BUTTON.....	53
(K)	FOAM INCREASE AND DECREASE BUTTONS .....	53
(L)	AIR/WATER PRESSURE DUPLEX GAUGE .....	53
(M)	HOME BUTTON.....	53
(N)	CURRENT PRESET .....	53
(O)	AIR DISPLAY .....	54
(P)	CAFS AIR/WATER FLOW RATIO .....	54
(Q)	CAFS ARC VALVE POSITION.....	54
(R)	CAFS POWER BUTTON .....	54
(S)	CAFS WET AND DRY BUTTONS .....	54
(T)	TANK-TO-PUMP VALVE BUTTON .....	54
(U)	AUTO-FILL MANUAL BUTTON .....	55
(V)	AUTO-FILL ON/OFF BUTTON .....	55
(W)	MENU BUTTON.....	55
(X)	ADDITIONAL INFORMATION DISPLAY .....	55
<b>FOAM/CAFS OPERATION .....</b>		<b>56</b>
ENGAGE THE PUMP .....		56
START FOAM/CAFS OPERATION BY SELECTING A PRESET (OR MANUAL) .....		56
INCREASE ENGINE SPEED FOR DESIRED WATER PRESSURE .....		57
SELECTING A NEW PRESET .....		57
MODIFY THE CURRENT OPERATING PARAMETERS .....		57
DISENGAGING THE COMPRESSOR CLUTCH.....		58
OVERHEAT SHUT DOWN .....		59
FLUSHING .....		59
<b>OPTIONAL WATER AUTO-FILL OPERATION.....</b>		<b>60</b>
SYSTEM LAYOUT.....		60
COMPONENTS .....		61
ENABLING AUTO-FILL .....		62
START/STOP AUTOMATIC AUTO-FILL .....		62
MANUALLY OPEN THE AUTO-FILL VALVE.....		63
SETTING THE DESIRED TANK LEVEL FOR AUTO-FILL .....		63
<b>MENUS.....</b>		<b>64</b>
SYSTEM MENU .....		64
SETTING THE SYSTEM TIME .....		64
USER MENU.....		65
(Y)	UP/DOWN ARROW BUTTONS .....	65
(Z)	“+” AND “-” BUTTONS.....	66
(AA)	EXIT BUTTON .....	66
(BB)	SAVE BUTTON.....	66
OEM MENU .....		66
(CC)	UP/DOWN ARROW BUTTONS.....	67
(DD)	“+” AND “-” BUTTONS .....	67
(EE)	EXIT BUTTON .....	67
(FF)	SAVE BUTTON.....	67
<b>CALIBRATIONS .....</b>		<b>68</b>
WATER FLOW CALIBRATION (STANDARD) .....		68
WATER FLOW CALIBRATION (DIRECT) .....		71
FOAM FLOW CALIBRATION .....		71
<b>CONFIGURATION .....</b>		<b>74</b>
PRESET CONFIGURATION (STANDARD) .....		74
PRESET CONFIGURATION (LIVE).....		75

**ON-SCREEN WARNINGS AND INFORMATION .....76**

**MAINTENANCE MINDER .....77**

**ROUTINE MAINTENANCE .....79**

AIR COMPRESSOR MOISTURE DRAIN..... 80

OIL AND OIL FILTER ..... 81

COOLING WATER STRAINER ..... 82

AIR CLEANER ELEMENT..... 82

**COMPRESSOR BELT MAINTENANCE .....83**

REMOVE BELT GUARD ..... 83

CHECKING BELT TENSION..... 84

ADJUSTING BELT TENSION ..... 85

**HOT SHIFT CLUTCH MAINTENANCE.....86**

CHANGING CLUTCH OIL..... 86

**MAINTENANCE SCHEDULE FOR SMARTCAFS.....87**

**MAINTENANCE OPERATIONS PUMP – SMARTCAFS.....88**

CAFS MIXING MANIFOLD – GREASING BALL VALVE ..... 88

LUBRICANTS:..... 88

VACUUM TEST PUMP MANIFOLD ..... 89

PRESSURE TEST – PERFORMED WITHOUT PUMP RUNNING..... 89

CAFS - SETTING THE AIR BALANCE CONTROL VALVES ..... 90

    1. SYMPTOMS OF IMPROPER ADJUSTMENT ..... 90

    2. FUNCTIONALLY TEST SMART CAFS AIR PRESSURE /WATER PRESSURE & ADJUST MATCH ..... 90

CAFS – HOT SHIFT CLUTCH ENGAGEMENT ..... 92

    1. THE HOT SHIFT CLUTCH IS ENGAGED WHEN THE CAFS SWITCH IS ACTIVATED..... 92

    3. SETTING THE HOT SHIFT CLUTCH ENGAGEMENT: ..... 92

**RECOMMENDED SPARES KIT FOR SERVICE .....93**

**HALE PUMP ILLUSTRATED PARTS LIST .....93**

**COMPRESSOR ILLUSTRATED PARTS LIST .....93**

**FOAM UNIT ILLUSTRATED PARTS LIST .....93**

**PARTS LIST.....94**

MAJOR ASSEMBLIES ..... 94

SMARTCAFS200 WIRING HARNESS ..... 96

THERMAL RELIEF VALVE..... 98

PARTS LIST – SUCTION MANIFOLD..... 99

PARTS LIST – DISCHARGE MANIFOLD..... 100

PARTS LIST – BELT GUARD & CAFS MIXING MANIFOLD ..... 101

PARTS LIST – OIL FILTER & STRAINER ..... 102

PARTS LIST – COMPRESSOR..... 103

PARTS LIST – SEPARATOR, OIL RESERVOIR..... 105

**QUICK REFERENCE GUIDE/TROUBLESHOOTING .....108**

AIR INJECTION/CONTROL ..... 108

COMPRESSOR OPERATION ..... 111

CAFS OPERATION..... 115

**LIMITED WARRANTY .....117**

## INTRODUCTION

This manual contains information relevant to HALE Series Pumps, when partnered with Compressed Air Foam Systems (CAFS) Foam unit Models 3.3, 5.0 and 6.5 and the UV SmartCAFS control system. Distinction between the models regarding Installation, Maintenance and Operation is clearly noted with text and illustrations.

For further information on the Foam unit 3.3, 5.0 and 6.5 Foam Proportioning Systems, MDTII Manual Dual Tank Selector, Compressor and Intelli-tank Water/foam level display unit, please see the separate manuals supplied.



Please read this manual before operating the pump.

**CRITICAL:** The pump, gearbox, separator tank and compressor assemblies are **NOT** filled with oil. These assemblies must be properly filled before operation of the CAFS system is permitted.

Correct lubrication and maintenance is essential if satisfactory performance is to be maintained.

Do not run the pump without water in the pump casing.



**THIS DSD SMARTCAFS IS AN INCOMPLETE SYSTEM FOR INSTALLATION IN A FIRE FIGHTING VEHICLE BY TRAINED INSTALLERS & DESIGNERS. THE INSTALLER OF THE SYSTEM IS RESPONSIBLE FOR PROVIDING SIGNIFICANT ELEMENTS FOR THE SYSTEM TO BE FULLY FUNCTIONAL AND OPERATIONAL. HALE PRODUCTS, INC. ASSUMES NO LIABILITY FOR INCORRECTLY INSTALLED APPLICATIONS AND NO WARRANTY WILL BE AVAILABLE FOR APPLICATIONS FAILING TO MEET THE CRITERIA OUTLINED WITHIN THIS MANUAL.**

## ENVIRONMENTAL PROTECTION

It is prohibited to pour engine oil and other contaminants onto the ground, down sewers, drains, or into water courses.

Dispose of lubricants through authorised waste disposal contractors, licensed waste disposal sites, or to the waste reclamation trade.

If in doubt, contact your Local Environmental Agency for advice regarding disposal policies.

## SAFETY - RELEVANT DATA

Thank you for purchasing a HALE Pump.

HALE Pumps are designed to give safe and reliable service. BEFORE use however, it is essential that the Operating and Installation Instructions are carefully read and understood.

### MAINTENANCE

It is the responsibility of the user to ensure that the equipment is maintained in a safe operational condition. Local legislative conditions may apply.

### TRAINING

It is ESSENTIAL that HALE pumps are operated ONLY by TRAINED PERSONNEL. Please contact HALE PRODUCTS, INC to discuss your training needs.

Follow the operating procedures outlined by the CAFS component suppliers in addition to the information provided here.



**READ ALL INSTRUCTIONS THOROUGHLY BEFORE BEGINNING ANY INSTALLATION PROCESS.**

- A compressed air foam system can be a valuable firefighting tool; however, proper operation and proper tactical use of this tool needs to be addressed through training and education. Further education and training on foam and compressed air foam is required for effective and safe firefighting use of this equipment. Dry foam is not recommended for structural fire suppression or direct fire attack.
- Make sure proper personal protective equipment is used when operating or servicing the apparatus.
- Rotating drive line parts can cause injury. Be extremely careful that NO part of your body (head, feet, arms, legs, finger, hair) is in an area of rotating parts where you could be subject to injury.
- Before attempting to start the CAFS system make sure to close all manual drains and discharge valves.
- Adding compressed air to the hose line dramatically increases the energy content. Hose lines charged with compressed air foam have very little weight but contain large amounts of energy.
- CAFS systems add power to the water stream via compressed air. Proper education, training and nozzle selection are required for operational effectiveness and safety. Greater nozzle reaction can be expected from some nozzles.
- **Nozzle selection** – Hale does not recommend any specific type or brand of nozzle for use with CAFS systems.

Each fire department must conduct its own evaluation to ensure an appropriate nozzle choice for the various types of hazards they expect to encounter. Each fire department or the authority having jurisdiction (AHJ) must develop associated operational procedures and guidelines. Hale Products, Inc. does not recommend or claim suitability or fitness for any given nozzle brand or style.





ONCE A NOZZLE HAS BEEN SELECTED IT IS IMPERATIVE TO PROVIDE AMPLE TRAINING IN THE USE OF THE NOZZLE. OPEN CAFS NOZZLES SLOWLY AND MAKE SURE THE NOZZLE IS SECURED AGAINST REACTION FORCE.

- Do not remove the cap from the FS series water strainer from the CAFS system while the unit is running.
- Projectiles can cause injury. DO NOT use a blank hose cap on CAFS discharges. CAFS stores energy in the form of compressed air in the piping that could turn a blank hose cap into a projectile when removed.
- DO NOT perform maintenance on the CAFS system while the unit is running. Make sure the system is shut down and components have cooled before attempting maintenance.
- The operating pressure range of the CAFS system is 75-150 PSI [5.1-10.3 Bar]. DO NOT EXCEED 150 PSI (10.3 BAR).



THE PROPER OIL LEVEL MUST BE MAINTAINED IN THE AIR COMPRESSOR SYSTEM AT ALL TIMES. LOW OIL LEVEL OR NO OIL COULD RESULT IN EXCESSIVE COMPRESSOR TEMPERATURE AND POSSIBLE COMPRESSOR FIRE. OVER FILLING COMPRESSOR SYSTEM CAN RESULT IN SYSTEM MALFUNCTIONING.

THE FIRE PUMP IS EQUIPPED WITH A MECHANICAL SEAL. DO NOT RUN PUMP DRY FOR EXTENDED PERIODS OF TIME OR SEAL DAMAGE COULD RESULT.

DO NOT EXCEED 220°F [105°C] DURING COMPRESSOR SYSTEM OPERATION AS INDICATED BY THE RED INDICATOR LAMP ON THE PANEL.

- DO NOT remove or alter any guard or insulating devices or attempt to operate the system when these guards are removed. Make sure all access/service panels and covers are installed, closed and latched tight where applicable.
- DO NOT remove or alter any hydraulic or pneumatic connections, electrical devices, etc. DO NOT tamper with or disconnect safety features or modify protective guards (such as covers or doors). DO NOT add or remove structural parts.

## NOISE

Operators must wear suitable EAR PROTECTION when the pump is running.

## GAUGES

Do not clean the glass surfaces of the gauges with abrasive or solvent cleaners. These will cloud the glass surface. Use a mild detergent and water.

## CLUTCH ENGAGEMENT

Clutch must be engaged between engine idle and engine 900 RPM to ensure clutch longevity.

**GENERAL DATA****COMPRESSOR**

Model	Enduro 12	
Maximum Operating Speed	6500 rev/min	
Nominal speed of operation	5000 rev/min	
Nominal power consumption	75HP	[56.0kW]
Direction of rotation	Counter-clockwise (viewed on pulley)	
Volume output	210 SCFM [5946 l/min] @ 125 PSI [8.6 Bar]	
Operational pressure range	75-150 PSI [5.1-10.3 Bar]	

**PUMP**

Minimum idle speed	600-700 RPM
--------------------	-------------

**COOLING SYSTEM**

Type	Oil / Water Plate Heat Exchanger
Cooling water flow-rate	13 G/min at 100Psi [50 l/min at 7.0 Bar]

**FOAM PROPORTIONING SYSTEM 3.3 - CLASS A AND B FOAM COMPATIBLE**

Manufacturer	Hale Products Inc.	
Model	Foam unit 3.3	
Type	Electronic foam proportioning system	
Operating voltage	12 and 24 volt systems available	
Fuse rating 12V / 24V	60 / 40 amp	
Current draw (Operating) 12V / 24V	30 / 15 amp	
Current draw (Max) 12V / 24V	60 / 30 amp	
Wire size	12V / 24V	Minimum 8.5mm <sup>2</sup>
Max. Foam Agent Flow rate	3.3 GPM [12.5 LPM]	

**FOAM PROPORTIONING SYSTEM 5.0 - CLASS A AND B FOAM COMPATIBLE**

Model	Foam unit 5.0
Max. Foam Agent Flow rate	5.0 GPM [19.0 LPM]
<i>Other data as per Foam unit 3.3</i>	

**FOAM PROPORTIONING SYSTEM 6.5 - CLASS A AND B FOAM COMPATIBLE**

Model	Foam unit 6.5 <1>
Max. Foam Agent Flow rate	6.5 GPM [24.6 LPM]
Current draw (Max) 12V / 24V	90 / 45 amp

NOTE <1> THE 12V SYSTEM USES A 24VDC MOTOR AND A 12 VDC TO 24 VDC CONVERTER.

For more information on the SmartFOAM units, refer to SmartFOAM Manual FSG-MNL-00158.

**FOAM PROPORTIONING SYSTEM DUAL 6.5 - CLASS A AND B FOAM COMPATIBLE**

Model	Dual Foam unit 6.5
Max. Foam Agent Flow rate	13.0 GPM [49.2 LPM]
<i>Other data as per Foam unit 6.5</i>	

## LUBRICANTS

### COMPRESSOR SYSTEM



**Recommended:** SAE 15W-40 automotive multigrade oil.  
**Capacity:** 8~9 Quarts [7.5~8.5 litres]

### PUMP GEARBOX

**Recommended:** SAE EP90, 80W-90 or 75W-140 Synthetic (Must meet service rating API GL-5)  
**Capacity:** 4 quarts [3.8 litres] approximately.

### CLUTCH HOUSING

**Recommended:** Dextron III or Mercon ATF.  
**Capacity:** 12 oz. [0.4 litres] approximately.

MAXIMUM INPUT RPM			
 <b>WARNING</b> 			
<b>EXCEEDING THESE LIMITS OR FAILURE TO FOLLOW THE RECOMMENDATIONS OUTLINED ON THIS DRAWING COULD DAMAGE THE PUMP AND RESULT IN PERSONAL INJURY.</b>			
<b>MAXIMUM GEARBOX SHAFT TORQUE (ROAD) = 16,000 LBS-FT [21,693 N-m]</b>			
MODEL	MAX GEARBOX INPUT RPM	MODEL	MAX GEARBOX INPUT RPM
23L	2630	23X	2580
21L	2920	21X	2810
19L	3220	19X	3060
SEE HALE TORQUE LIMIT CHART F-72 FOR ADDITIONAL DATA. MAXIMUM ALLOWABLE HYDRODYNAMIC PRESSURE: 400 PSIG MAXIMUM ALLOWABLE HYDROSTATIC PRESSURE: 600 PSIG			

## MODEL IDENTIFICATION SYSTEM

The HALE type pumps are available at the following NFPA ratings:

# QMAX150-23LC

PUMP MODEL	PUMP		GEARBOX		ACCESSORY	
TERM	RATED CAPACITY (IMPERIAL)		L-GEARBOX		TERM	VARIANT
DSD	TERM	RATING	TERM	RATIO	C	CAFS
QMAX	75	750 GPM	19L	1.86		
QMAXXS	100	1000 GPM	21L	2.05		
QTWO	125	1250 GPM	23L	2.28		
	150	1500 GPM	X-GEARBOX			
	175	1750 GPM	TERM	RATIO		
	200	2000 GPM	19X	1.96		
	225	2250 GPM	21X	2.13		
	250	2500 GPM	23X	2.32		
	300	3000 GPM				
	350	3500 GPM				
	RATED CAPACITY (METRIC)					
	TERM	RATING				
	300M	3000 LPM				
	400M	4000 LPM				
	500M	5000 LPM				
	600M	6000 LPM				
	700M	7000 LPM				
	800M	8000 LPM				
	900M	9000 LPM				
	1000M	10000 LPM				
	1200M	12000 LPM				
	1400M	14000 LPM				

For example, the QMAX pump specified above has a 1500 GPM rating with a 2.28 rear ratio in the CAFS configuration. The pump model identification is at the bottom of the gearbox:

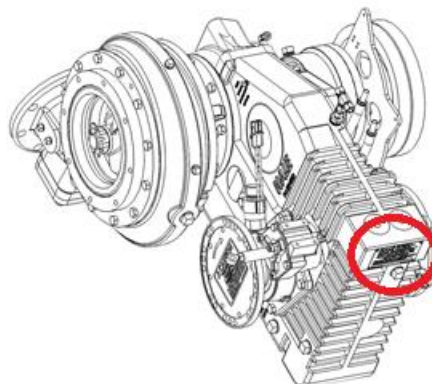

Figure 1: Gearbox Identification Placard

## RECOMMENDED FOAM AGENTS

Hale Foam unit Models 3.3, 5.0, 6.5 can be used with the foam concentrates specified on the Hale Foam Proportioning System Foam Concentrate Compatibility List [Hale Bulletin #650, Rev 33, 11-11-11](#). Check [Hale website](#) for the latest updates.

The foam concentrates in the list have been tested by Hale Products to ensure compatibility with Foam unit systems. This information is intended to assist the end user (AHJ) in selecting compatible foam concentrate(s) but is not a determination of firefighting efficiency. Always consult local application and environmental regulations before selecting the foam concentrate and refer to the Foam unit user manual for additional information.

# MAJOR COMPONENTS AND CONTROLS

## GENERAL ARRANGEMENT

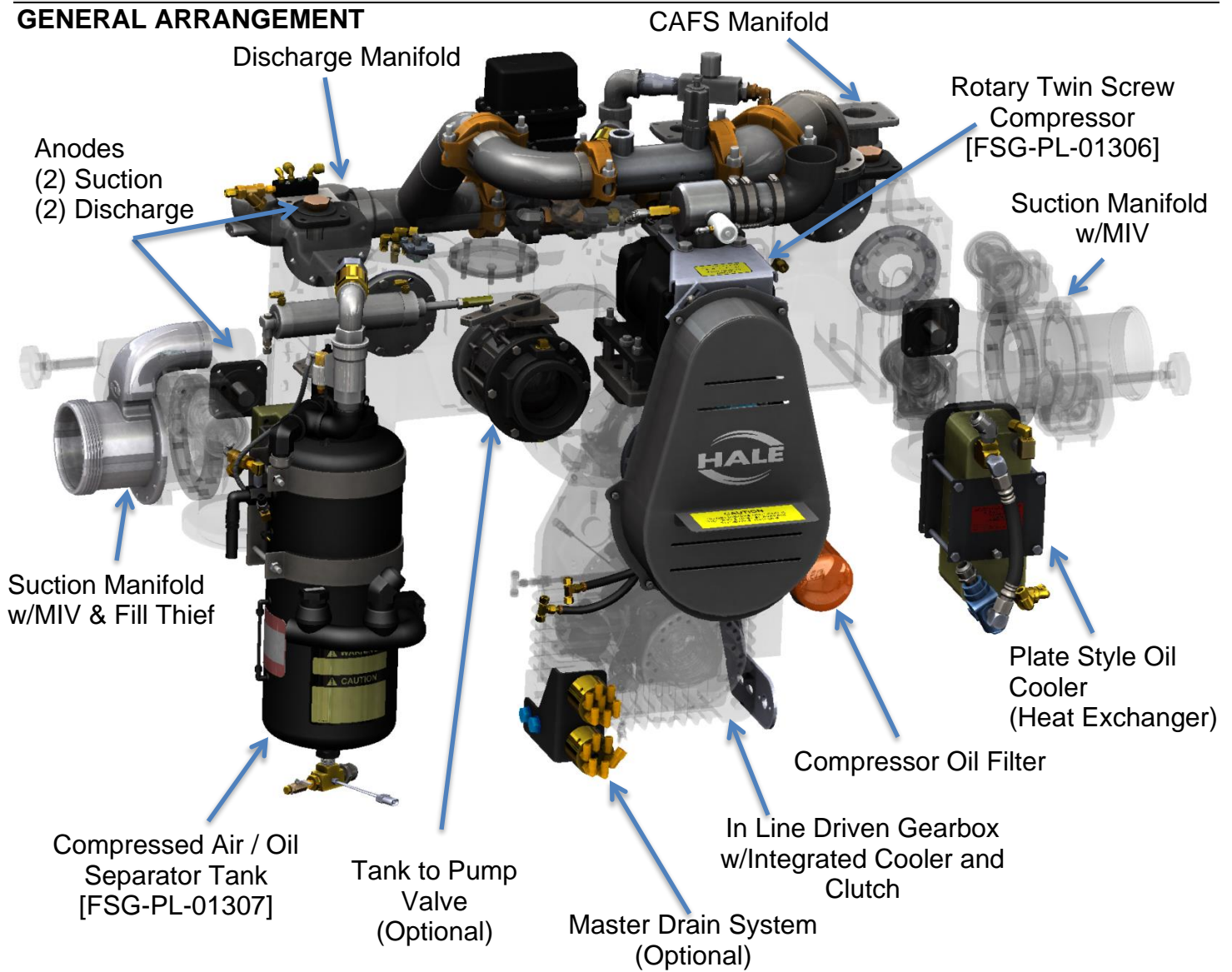

Figure 2: Q-SERIES version shown. Drawing numbers are shown in brackets [FSG-PL-XXXXX].

### SMARTCAFS MIXING MANIFOLD

#### (a) Volute Style Pump

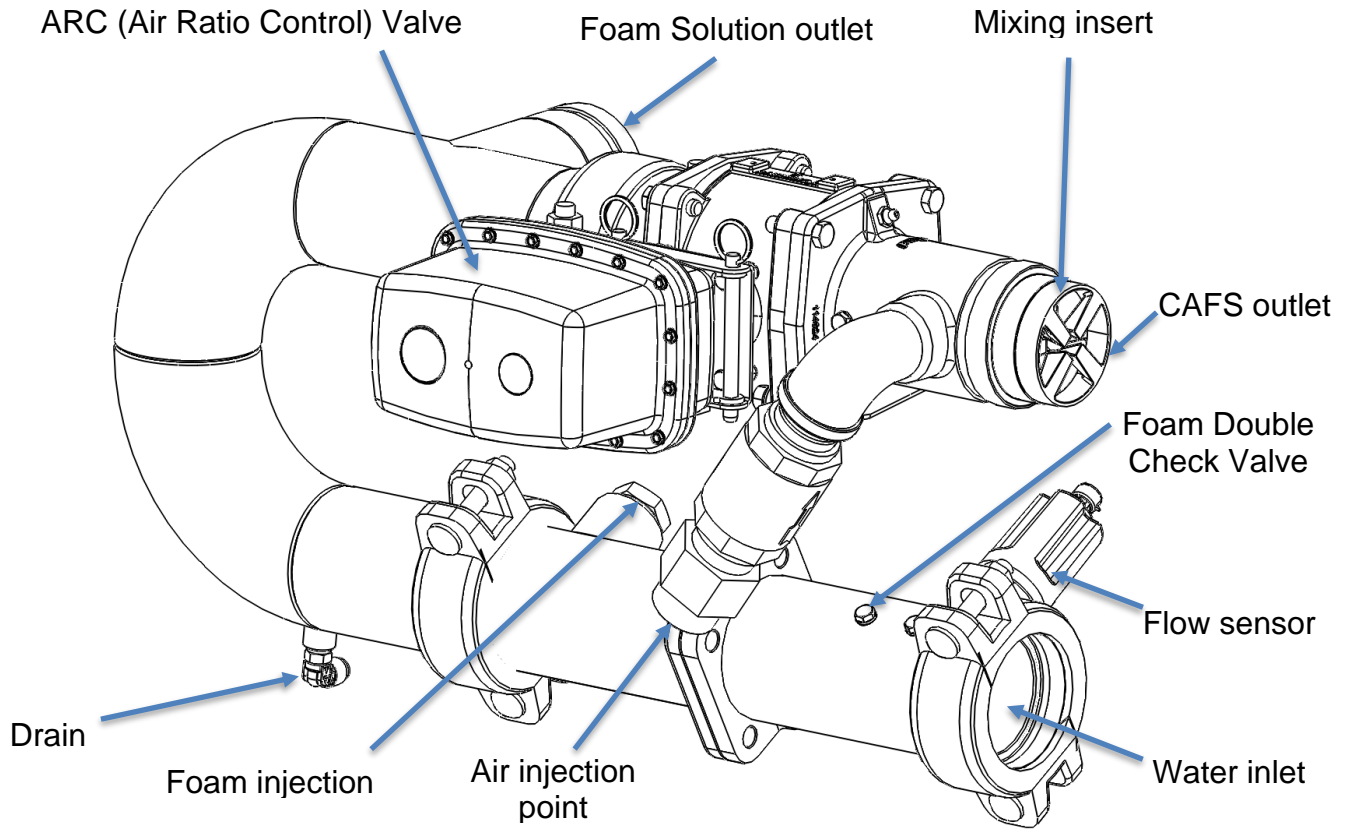

Figure 3: DSD CAFS Mixing Manifold

**(b) High Pressure**

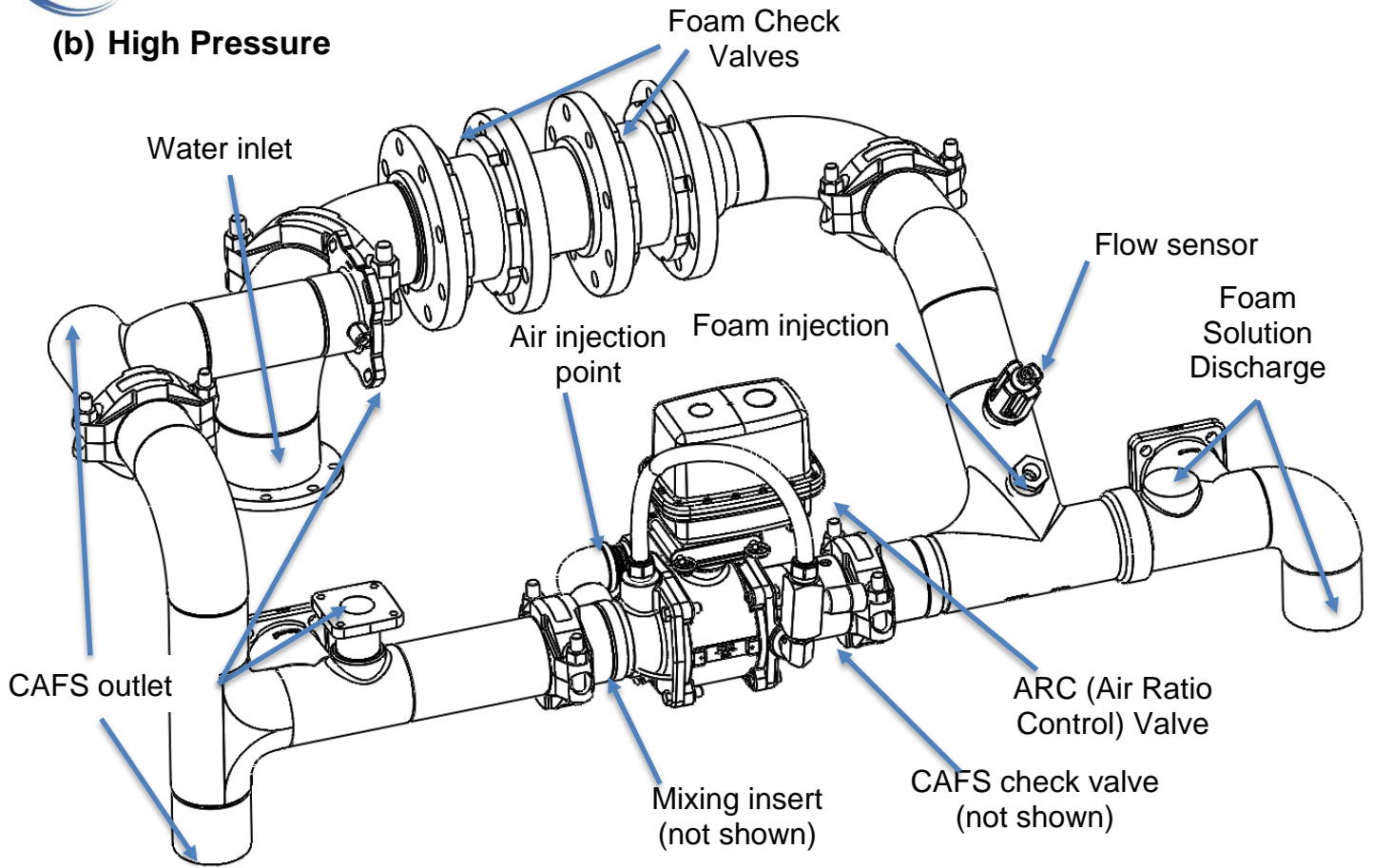

Figure 4: QTWO High Pressure CAFS Discharge

**(c) Standard Pressure**

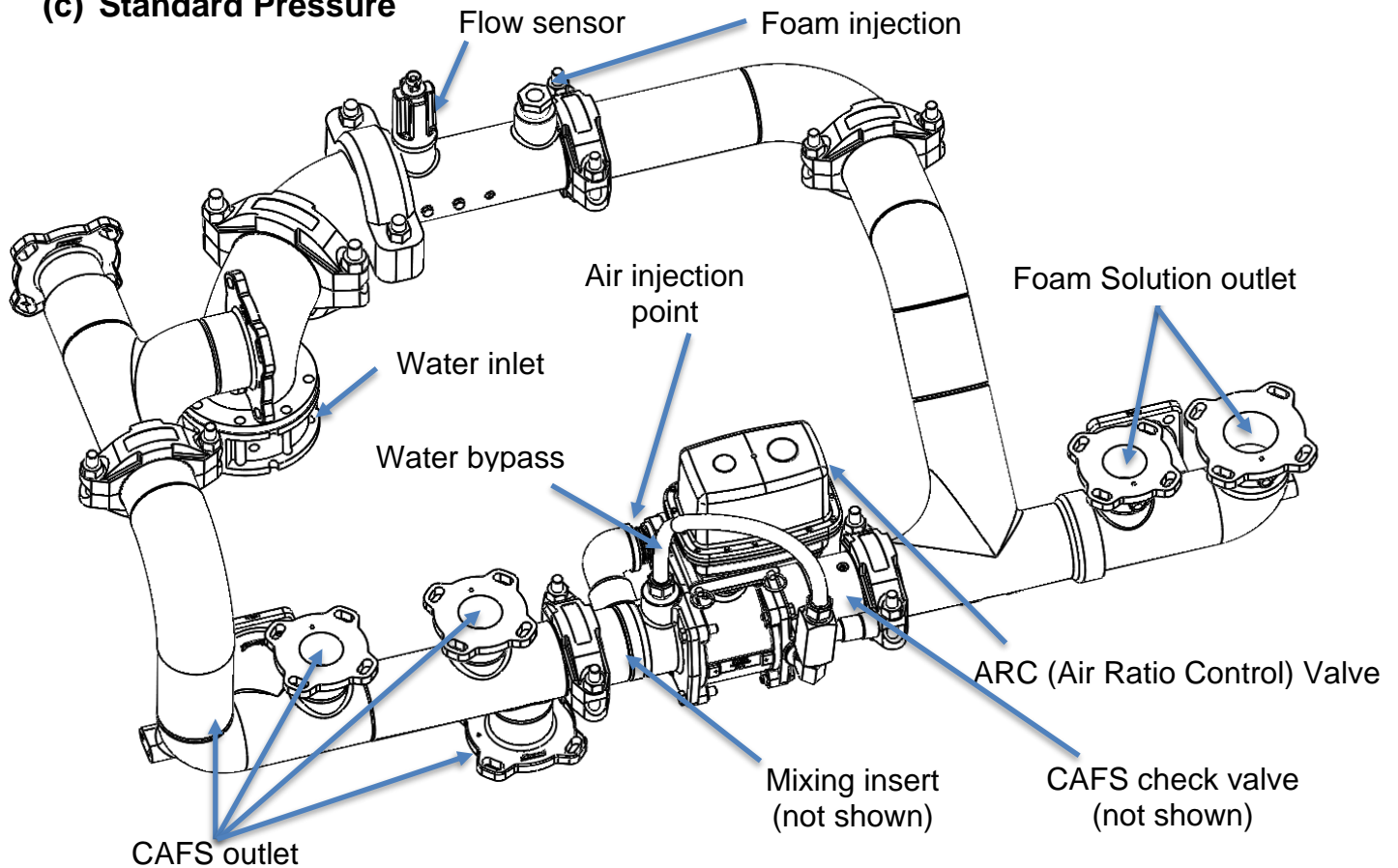

Figure 5: Standard Q-Series CAFS Discharge Manifold



### FOAM UNIT 3.3, 5.0, 6.5 FOAM PUMP COMPONENT GROUP

**NOTE:** Hale Foam unit 3.3, 5.0 or 6.5 foam pump is supplied loose for mounting by vehicle builder.

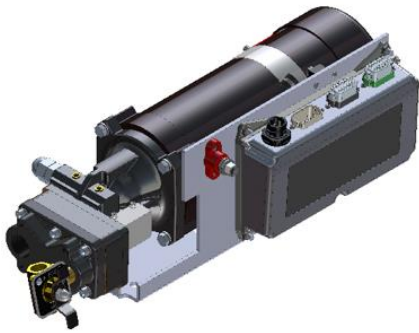

Figure 6: Foam Pump



Figure 7: In-Line Strainer



Figure 8: Water Strainer



Figure 9: ADT Selector



Figure 10: MDT Selector



Figure 11: MST Selector



Figure 12: Bottom Low Level Tank Sensor



Figure 13: Side Low Level Tank Sensor



Figure 14: Top Low Level Tank Sensor

### CONTROL PANEL - SMARTCAFS

Master Gauge (Optional)      Master Drain Air Switch (Optional)      Audible Overspeed Alarm      SmartCAFS Control Display

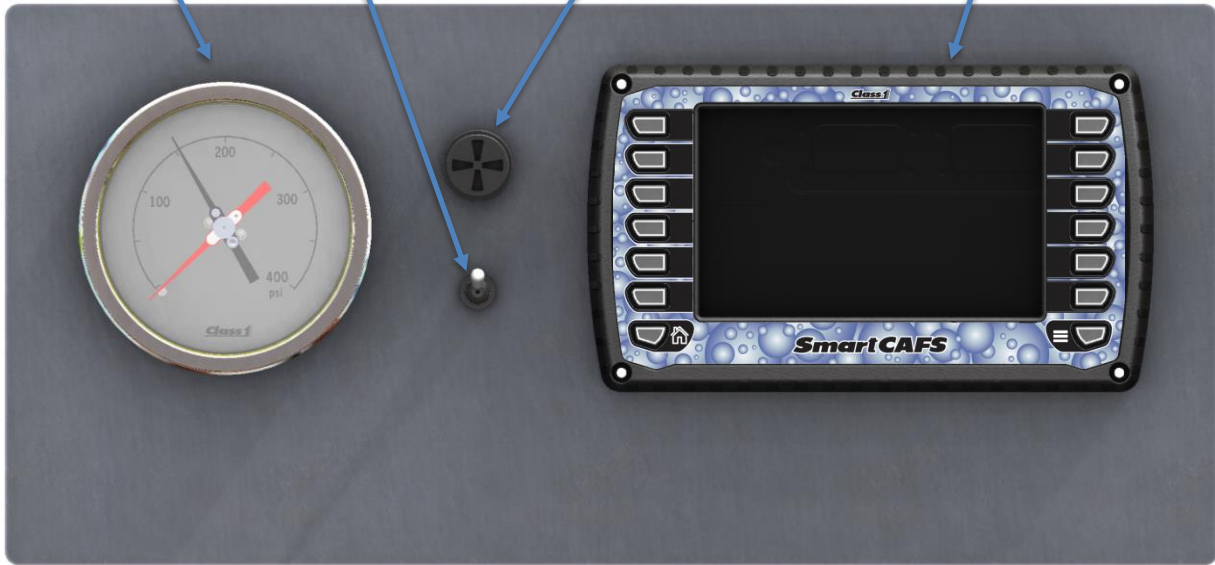

Figure 15: SmartCAFS Testing Panel

### COMPONENT PANEL CUT-OUT DIMENSIONS

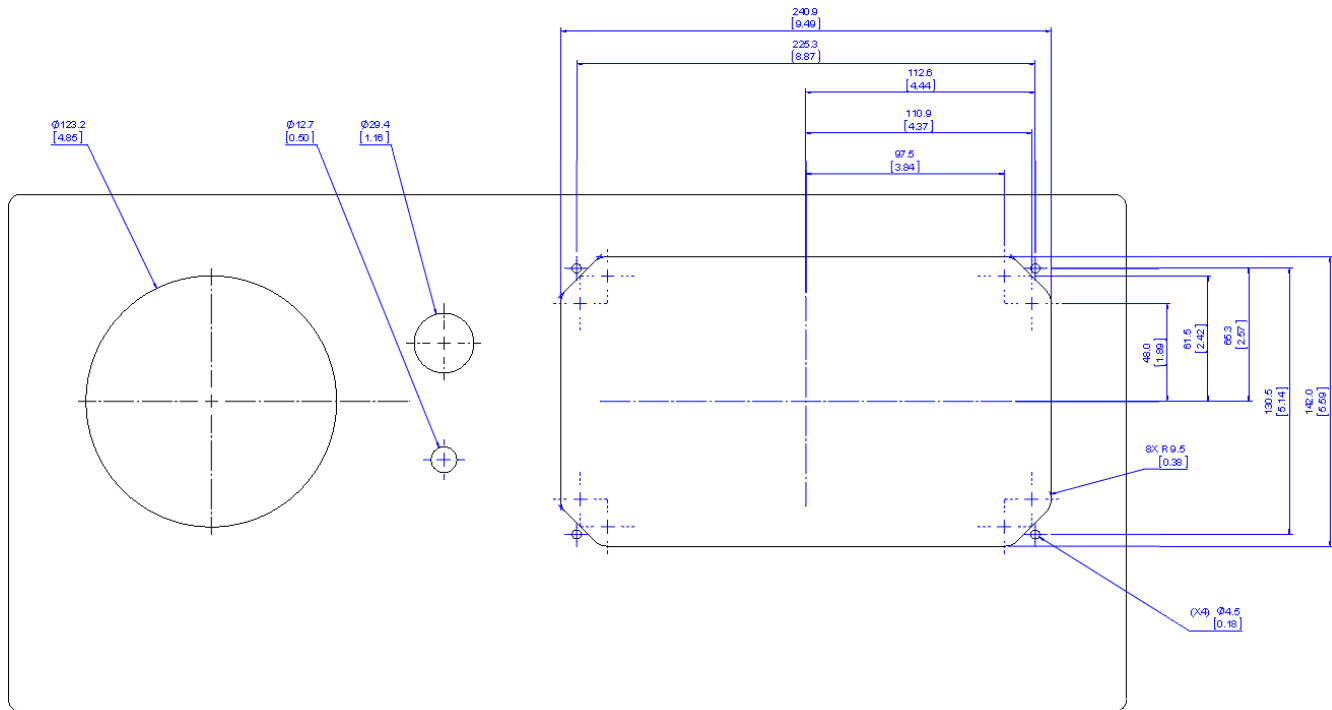

Figure 16: Installation Cut-out Dimensions

## SYSTEM OVERVIEW

The SmartCAFS is a Compressed Air Foam System comprising of two major components (in addition to the main water pump) – Air compressor system (with separate heat exchanger and oil/water separator) and Foam unit system (foam proportioning unit).

The Foam unit foam pump and motor assembly is mounted separately from the water pump and is designed to be remotely mounted according to the [Foam unit Installation Manual](#).

A metered amount of foam concentrate is introduced into the manifold and mixed with water from the pump discharge manifold to produce a solution. The foam and water solution is then fed to a control valve (ARC) where wet or dry foam may be selected (air ratio control section of manifold). Compressed air is then injected and the resulting foam / water / air combination is completely mixed by the X-mixers inside the discharge manifold creating CAFS discharge flow.

### SAFETY INTERLOCKS ARE PROVIDED TO ENSURE THAT:

1. Foam concentrate cannot be introduced unless water is flowing through the unit. Compressed air cannot be introduced unless foam concentrate is flowing.
2. 'Slugging' (unmixed air and water) in the discharge line is prevented. Air cannot be injected in the absence of foam and water.
3. Air injection when the foam tank is empty is prevented. Foam tank low level switches are provided and MUST be fitted.

### COMPRESSOR

The rotary twin-screw compressor is rated at 210 SCFM [5946 l/min] @ 125 PSI [8.6 Bar] per NFPA and is driven by a synchronous belt. The compressor is engaged, or disengaged from the pump drive at idle, via an air-operated, oil lubricated friction plate clutch.

### OIL COOLER

Compressor lubricating oil is cooled by water taken from the main pump, via the water supply line; cooling water being supplied from pump delivery and returned to truck tank. The compressor will reject up to 43HP [32.0 kW] of heat energy to cooling. The installer must consider this additional thermal load. When the compressor is turned off, residual system pressure is vented by a blow-down valve. The system should not store compressed air energy when shut off.

**NOTE:** *The compressor should not be run without cooling water and proper oil level for both the compressor and separator tank.*

### SEPARATOR TANK

The separator tank holds the oil required for lubricating the compressor and separates the oil from the oil/air mix discharged from the compressor. The separator tank also has a minimum pressure valve that ensures that air pressure is maintained above 43.5PSI [3 bar] to maintain correct lubrication.

## MANIFOLD

The manifold incorporates an ARC Valve [air ratio control valve] through which degrees of wet or dry foam mixture can be selected. Compressed air is then injected and the resulting foam / water / air combination is thoroughly mixed by the X-mixers during discharge.

For salt water compatible foams or a specific solution's effectiveness while using salt water, seek advice from the foam agent manufacturers.

## FOAM UNIT - FOAM PROPORTIONING SYSTEM

The Foam unit system consists of three main components:

- 1) Foam Pump / Motor Assembly.
- 2) Control Panel (integral with main pump control panel).
- 3) Flow measurement and injection manifold.

All three elements combine to provide accurate foam proportioning. From the control panel the operator can initiate the system, adjust the foam ratio, monitor 'real time' water flow rate and record total water and foam concentrate usage.

Foam concentrate is only injected when the foam button has the **RED** selector around the control button.

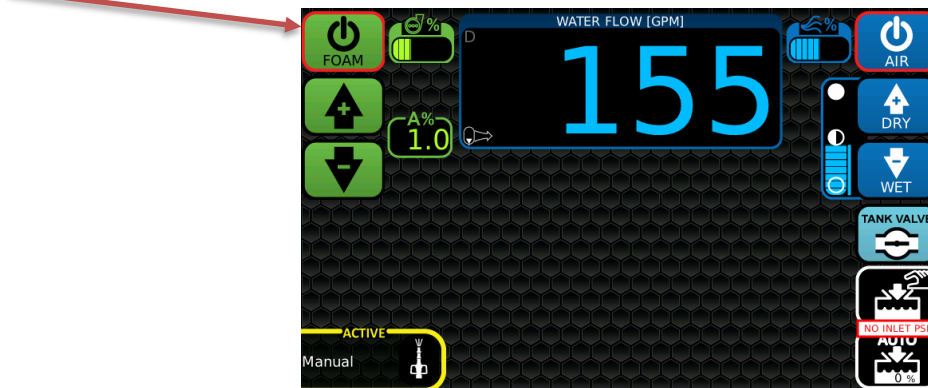

Figure 17: SmartCAFS Foam/CAFS Screen

The Foam unit 3.3, 5.0, 6.5 system for Class A or B foams, will inject foam in the range of 0.1% to 10.0%.

Further information is available in the **Foam unit Model 3.3/5.0/6.5** Description, [Installation and Operation manual](#).

## FOAM UNIT 3.3, 5.0, 6.5 SYSTEM – REMOTE MOUNTED

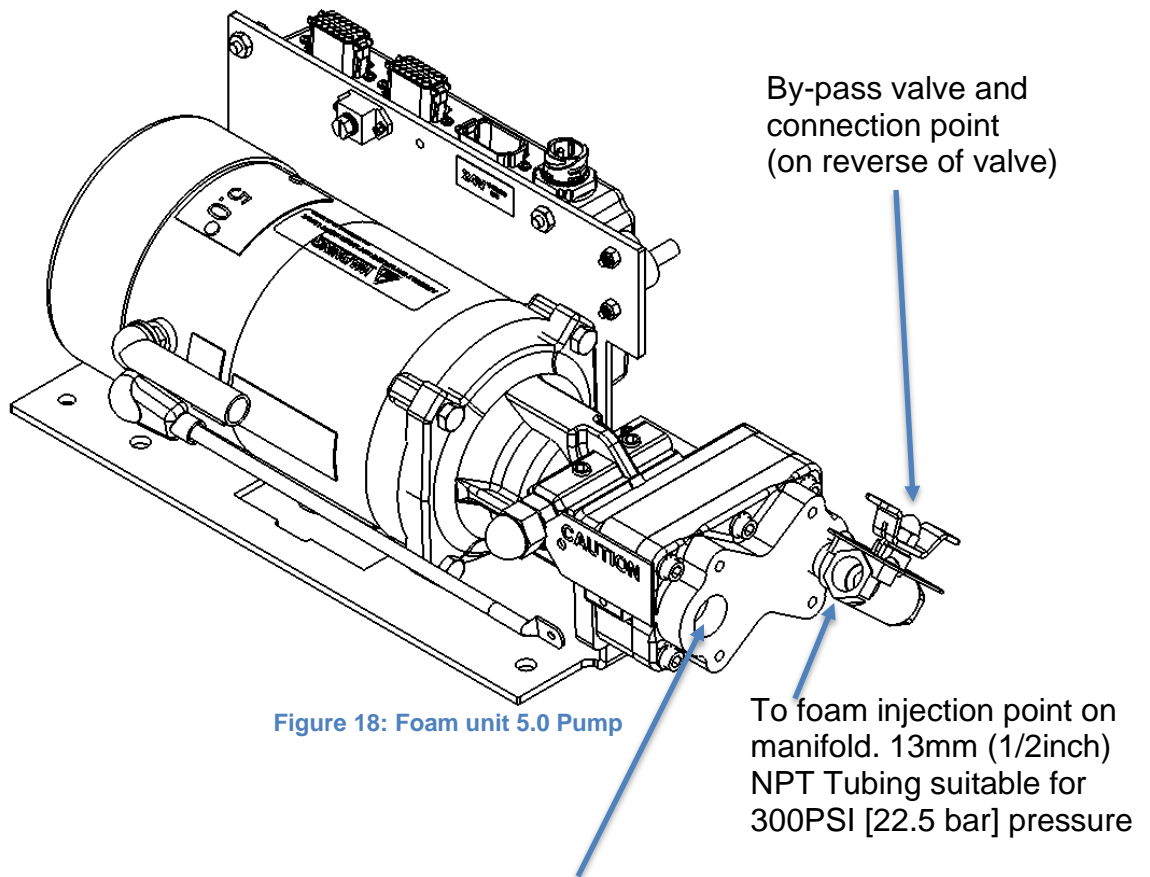

Figure 18: Foam unit 5.0 Pump

Inlet from foam strainer,  
Models 3.3, 5.0 – 19mm (3/4inch) NPT  
Model 6.5 – 25.4mm (1inch) NPT

Note: Foam tank must be located above SmartFOAM unit.

Also refer to installation notes in SmartFOAM manual (FSG-MNL-00158).

### FOAM UNIT DIMENSIONS

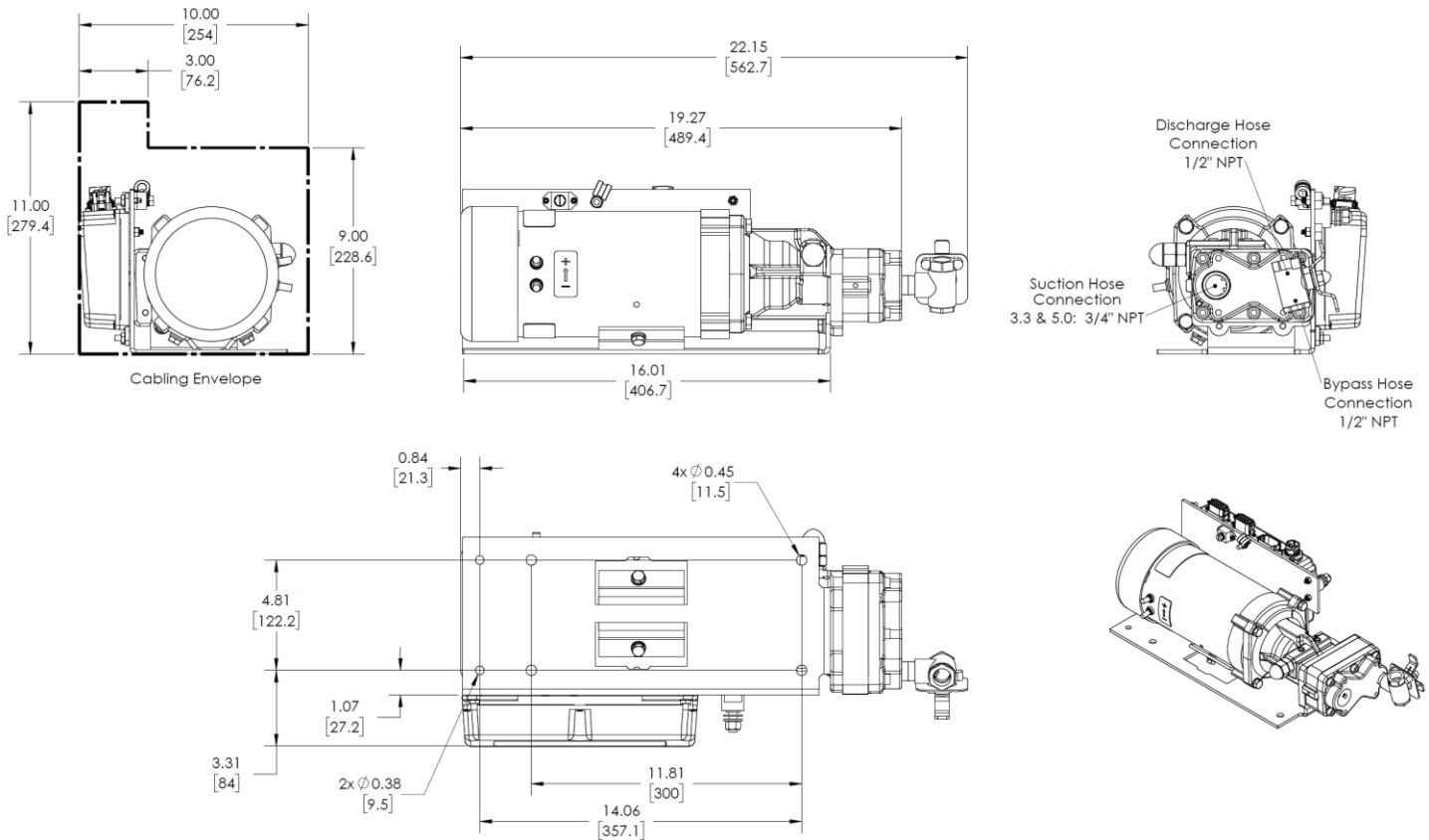

Figure 19: Installation Envelope Dimensions for 3.3 and 5.0 Foam Pumps

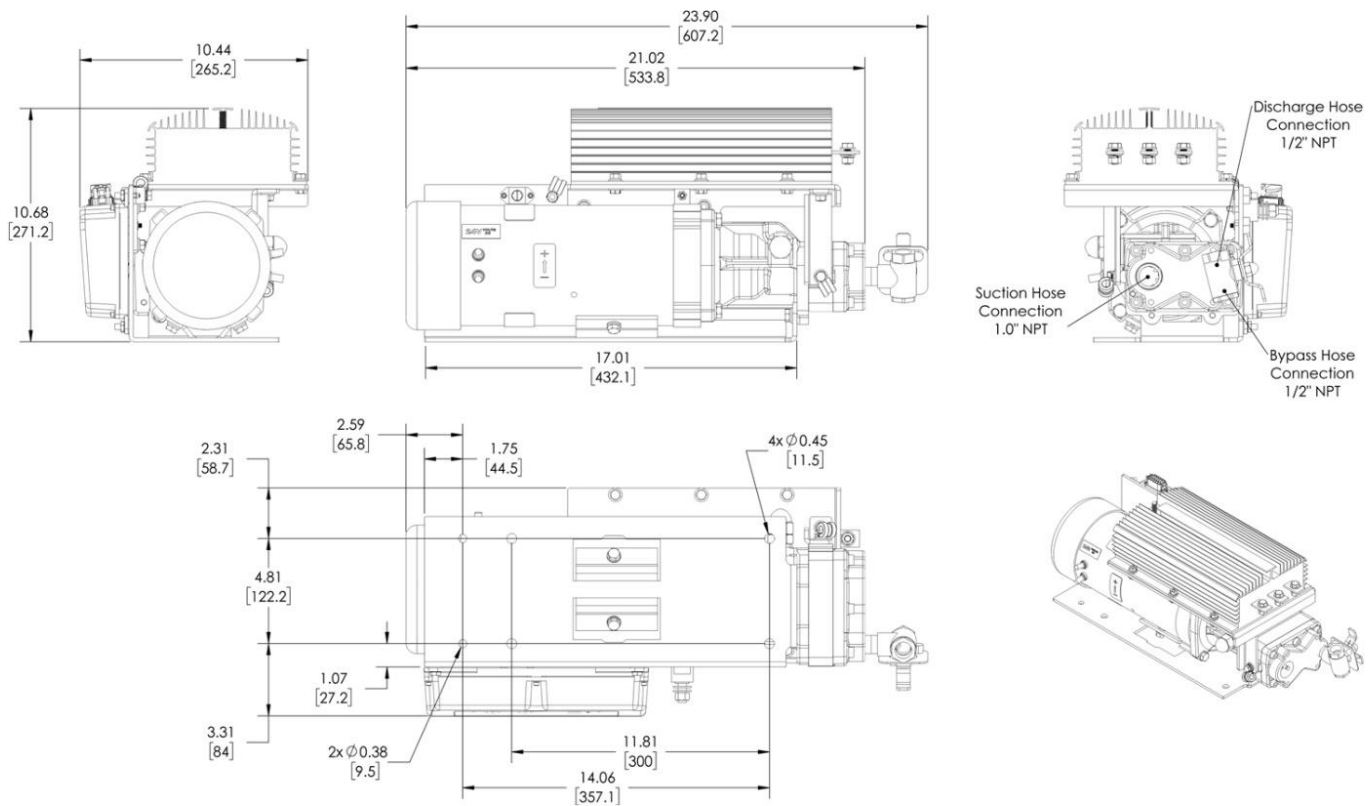

Figure 20: Installation Envelope Dimensions for 6.5 12 VDC Foam Pump (Converter Installed)

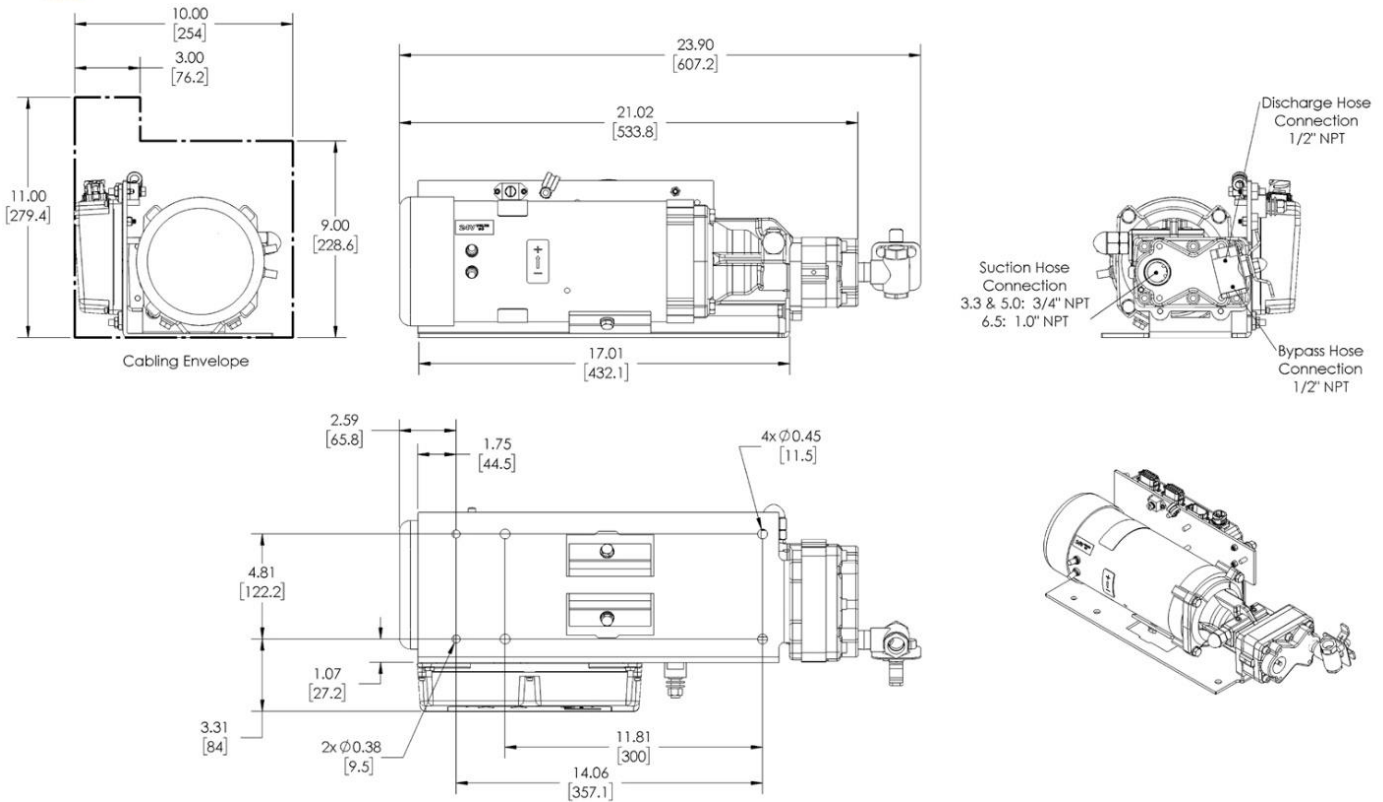

Figure 21: Installation Envelope Dimensions for 6.5 24 VDC Foam Pump

## INSTALLATION AND INITIAL SET-UP

The following connection points should be considered when installing the DSD SmartCAFS assembly into a vehicles frame.

### LIFTING POINTS

Secure handling of the unit for installation and maintenance is vital. Use only the lifting points noted below.

- Primary lift point is the main Gearbox mount bracket.
- Front to rear “balance” lift point is the suction manifold.
- Do NOT use the discharge manifold as a lift point.

### STRAP LIFT POINTS

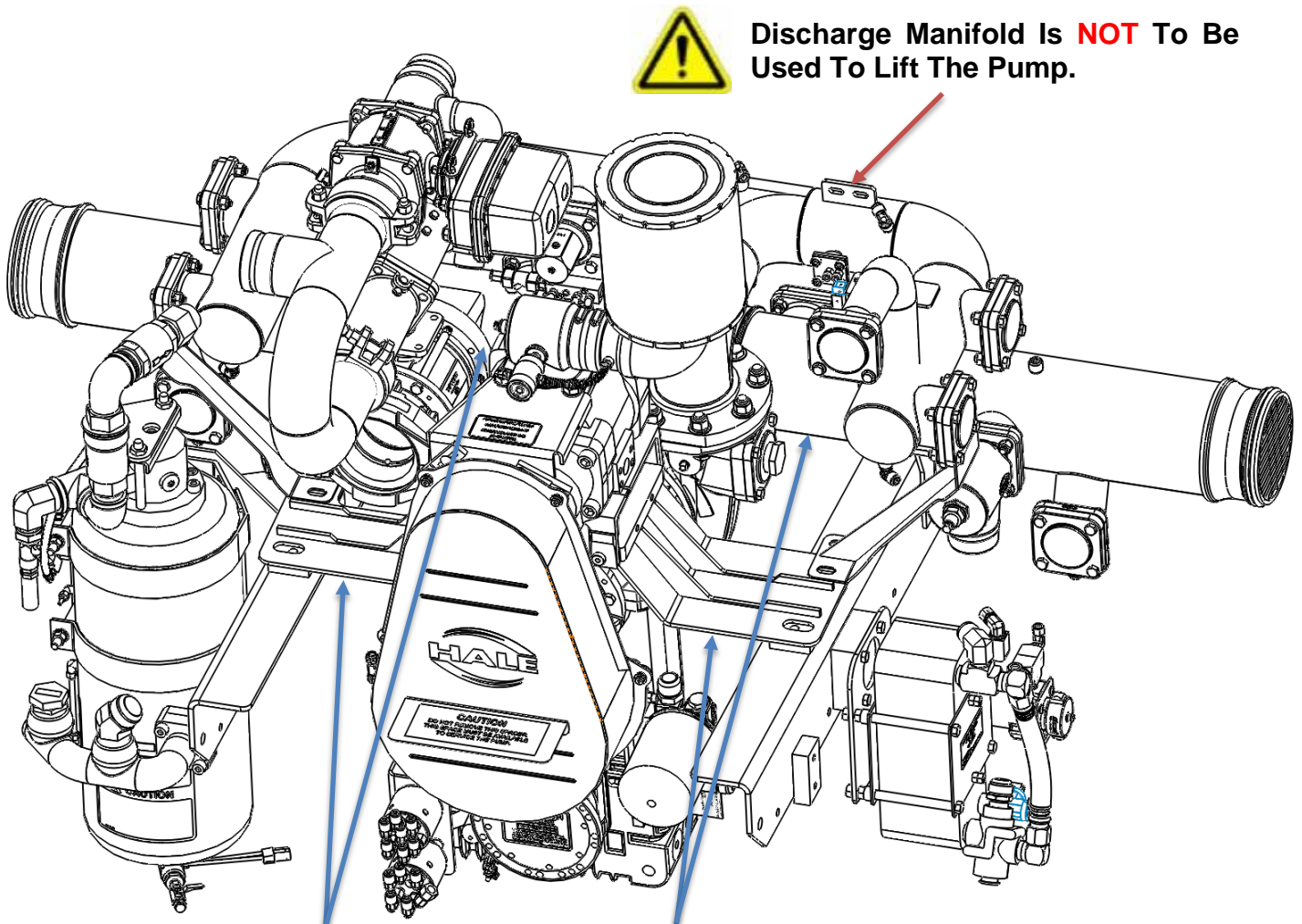

Discharge Manifold Is **NOT** To Be Used To Lift The Pump.

**Main Support Bracket & Suction  
Manifold, Inboard of Frame  
Mounting Rails.**



## DRIVE LINE

For driveline flange connection, appropriate driveline, shouldered hardware in the quantity and size specified must be used.

Due to the increasing sophistication of fire apparatus and truck design, there is potential for an increase in the number of driveline problems.

Flange Series	Qty.	Size
1600, 1610 1650, 1700 1710	8	3/8" (9.5mm)
1780, 1800 1810	12	7/16" (11mm)

These problems include: drive shaft failure, loosened drive ends on pump gearboxes, broken mounting brackets, driveline joint or slider wear, bearing wear on pumps or rear axles, and vibrations at specific road speeds. While the incidence of these problems is low, they are expensive to fix yet easy to avoid.

It is critical to use computer driveline analysis software, such as Dana's "The Expert," during driveline layout. Dana's software is available free on the World Wide Web at:

<http://www2.dana.com/expert/>

While using the software, perform three separate driveline analyses:

- Front drive shaft assembly
- Rear drive shaft assembly
- Total system

Ensure individual shaft cancellation and correct phasing.

When performing calculations, strive to achieve the lowest driveline torsional and inertial vibrations, making sure to avoid severe driveline angles. Be conservative and always err on the side of SAFETY. Always measure the drive shaft after construction to make sure it matches the computer design.

Remember the following points while designing a driveline.

- Problems can occur with or without noticeable vibration.
- Suspension travel and torque wrap-up can change a marginal driveline into one that is unacceptable. Always consider the full movement of the driveline.
- Center your driveline sliders and ensure they have sufficient travel to allow for the entire movement of the suspension.
- Do not measure driveline angles using a bubble protractor. Instead, use a digital inclinometer. Remember to zero the inclinometer on the truck frame, not the ground.
- Split-shaft drivelines inherently have yoke phasing that can change with every shift. This is one reason to design the other aspects of the drive-line more conservatively than a "non-split shaft" truck driveline. Long drivelines can lead to component vibration or failure. As the driveline approaches half critical speed, a vibration can occur that could damage driveline components. This is much more critical in fire apparatus with split shaft pumps. The phasing

between the front and rear shafts changes every time the pump is used.

Maximum Recommended Driveline Lengths lists the maximum driveline length using a safety factor of 42% of critical speed. This table is based on a 0.134" (3.4 mm) wall thickness.

Shaft RPM	2.0 (51)	2.5 (64)	3.0 (76)	3.5 (89)	4.0 (102)	4.5 (114)
2,400	47 (1,194)	53 (1,346)	58 (1,473)	63 (1,600)	76 (1,702)	71 (1,803)
2,600	45 (1,143)	51 (1,295)	55 (1,397)	60 (1,524)	64 (1,626)	68 (1,727)
2,800	44 (1,118)	49 (1,245)	53 (1,346)	58 (1,473)	62 (1,575)	65 (1,651)
3,000	42 (1,067)	47 (1,194)	52 (1,321)	56 (1,422)	60 (1,524)	63 (1,600)
3,200	41 (1,041)	46 (1,168)	50 (1,270)	54 (1,372)	58 (1,473)	61 (1,549)
3,400	39 (991)	44 (1,118)	48 (1,219)	53 (1,346)	56 (1,422)	59 (1,499)
3,600	38 (965)	43 (1,092)	47 (1,194)	51 (1,295)	55 (1,397)	58 (1,473)
3,800	37 (940)	42 (1,067)	46 (1,168)	50 (1,270)	53 (1,346)	56 (1,422)
4,000	36 (914)	41 (1,041)	45 (1,143)	48 (1,219)	52 (1,321)	55 (1,397)

- Although wall thickness does not have a significant effect on drive shaft length for this calculation, it does have some effect. Contact driveline supplier for additional information.
- Extremely short drive lengths between the pump and the rear axle can also cause problems from excessive operating angles when the suspension articulates. Use caution and conservative design values when utilizing air ride suspension and short rear drivelines.
- For application assistance and approval, contact a driveline equipment manufacturer, such as Spicer/Dana or Meritor.

Position the unit onto the truck frame in the required location.

- Bolt the pump frame rails onto the truck frame. (DSD Unit pictured).

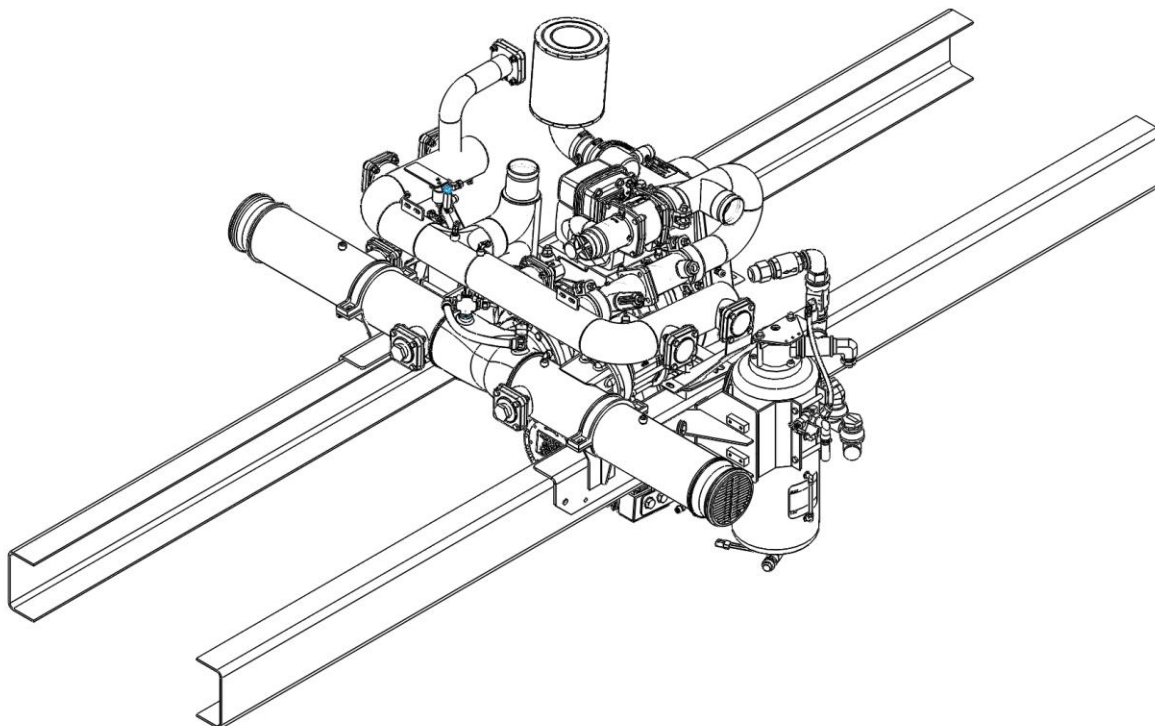

Figure 22: DSD Frame Rail Placement

## PUMP CLEARANCE

- Pump service area is depicted within the zones illustrated below. DSD unit pictured, but clearances for drive belt and anodes are common among all units.
- A pump clearance plate is installed to the pump guard to ensure proper clearance for major pump service. This plate must remain on the pump.
- Suction manifold: Anode service areas are also required.
- DO NOT install any other components in this area that cannot be easily removed.

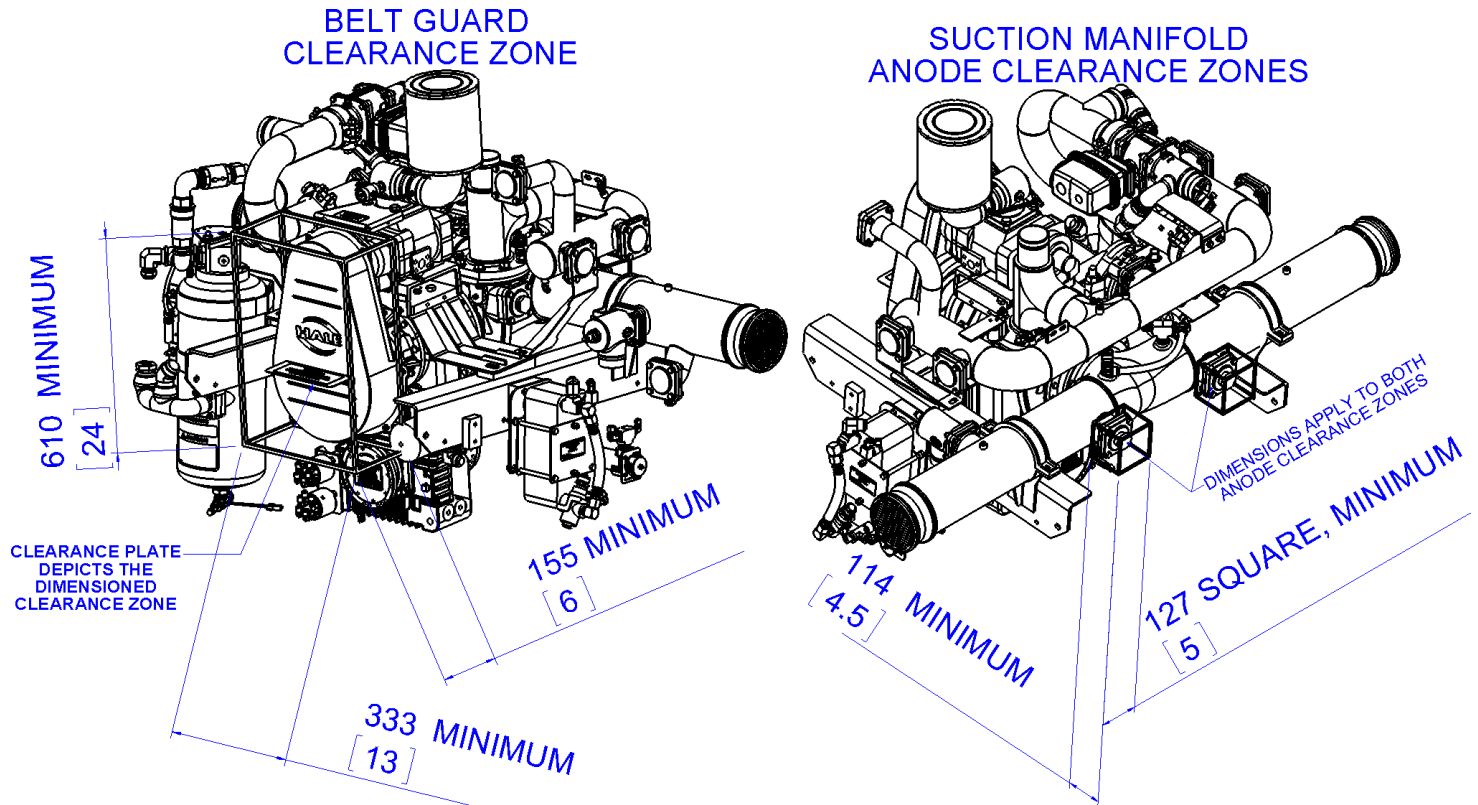

Figure 23: Service Zones Pictured (Dimensions are recommended minimums)

## PANEL STRAINER

- The CAFS system cooling water strainer is mounted to the pump panel through a 2-1/8" (54 mm) hole, with the supplied placard as shown in **Figure 25**.
- Plumb 3/8" (9.5 mm) tubing between the tee, mounted on the bottom of the strainer, and the drain valve.
- Also see [Plate # PL977](#) for additional info.

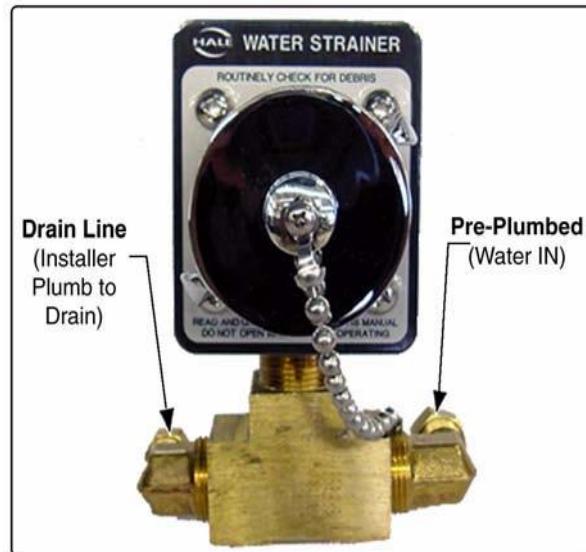

Figure 24: Water Strainer Plumbing

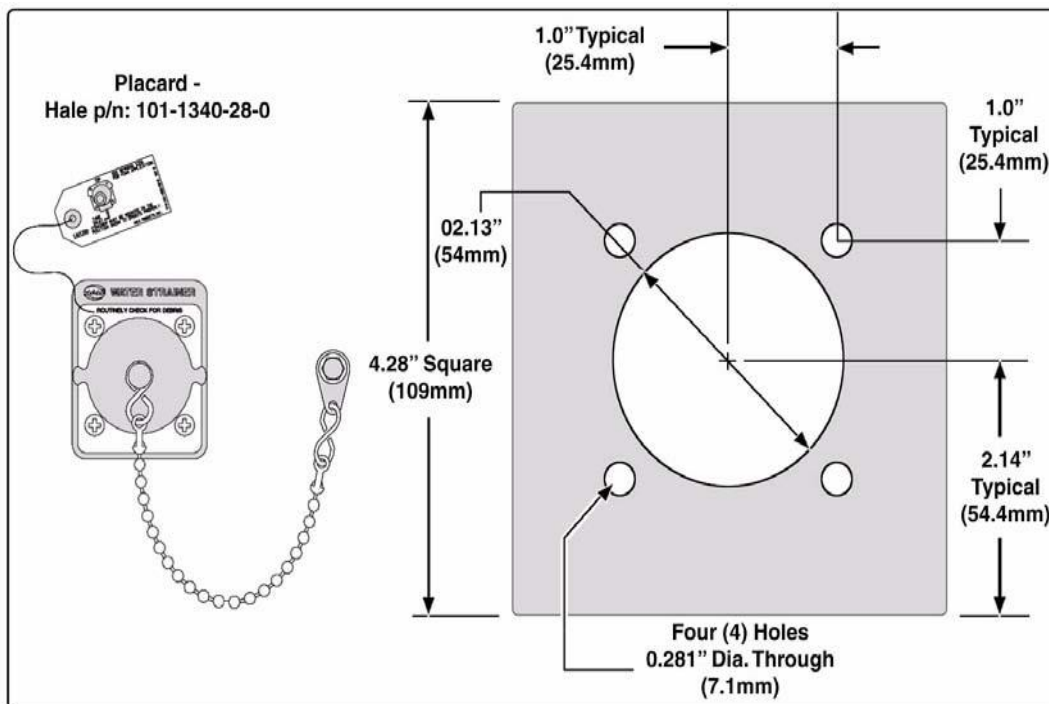

Figure 25: Water Strainer Cut-out

## COMPRESSOR CONNECTIONS

- For reliable operation, the CAFS air filter must be located in a clean, fresh-air environment, usually in the dunnage area above the pump compartment. DO NOT damage the filter during assembly and be sure the mounting area offers protection.
- Mount the air filter 6" (152 mm) MINIMUM above the decking platform to prevent standing water from being sucked into the filter and possibly back into the system. (See Figure 27)
- Use 3" (76.2 mm) CPVC or aluminum pipe and rubber connections. Support the piping with brackets as needed.

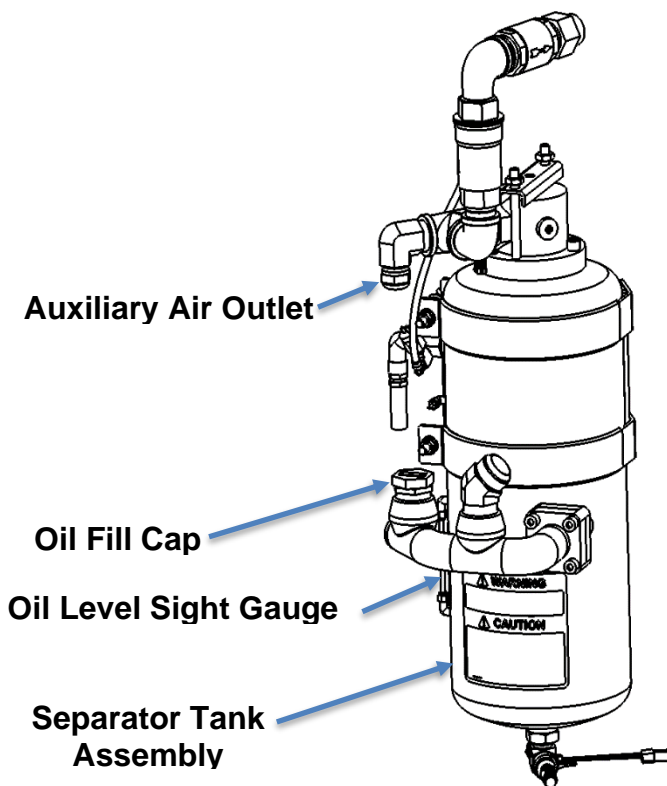

Figure 26: Separator Part Identification

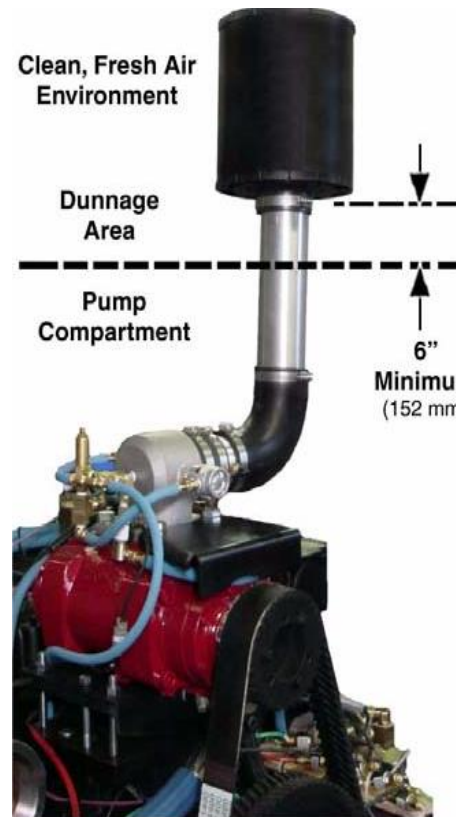

Figure 27: Air Intake Installation

- An auxiliary air outlet for rescue tools and testing can be provided. Refer to NFPA CAFS testing requirements. A fitting is provided, with JIC cap, on the outlet of the separator tank.



If the auxiliary air is connected & used for rescue tools, the DSD pump should be connected to a fresh water source to prevent overheating of the compressor as the cooling system for the compressor relies on a continuous fresh water source. If the truck tank is the only water source for cooling the compressor, the auxiliary air source can be utilized for a shorter period of time depending on the truck's tank size.

- Remove the protective cap, and install an appropriate hose. Use 3/4" (19 mm) to 1" (25.4 mm), wire reinforced hose for maximum air flow. For example, Aeroquip FC350-16, 1" (25.4 mm) wire reinforced hose.

- A quick disconnect and ball valve should be installed on the panel to control air flow from aux air outlet.

### COMPRESSOR OIL SERVICE ACCESS

- To allow access for compressor and pump servicing, a panel with approximately 450 square inches of area and no dimension less than 18" (457 mm) must be provided.
- Include a service door to inspect the receiver tank oil level and provide access to the oil fill fitting. The service door should measure 14" x 14" (356mm) minimum. See figure below.



**DO NOT REMOTE CONNECT OR EXTEND THE OIL FILL LINE. EXTENDING THIS LINE ALLOWS FOR POSSIBLE OVERFILL WHICH WILL CAUSE SERIOUS DAMAGE TO THE COMPRESSOR.**

Affix the WARNING / CAUTION decal (Hale P/N 101-1410-01-0) to the inside of the receiver tank service door.

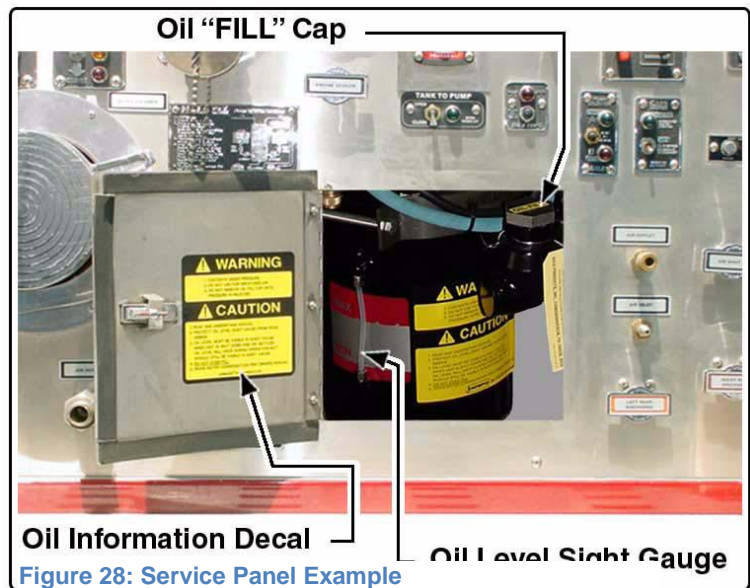

Figure 28: Service Panel Example

### Fluid Drain Points

1. For detailed operation, maintenance & care of the DSD SmartCAFS pump, refer to 8FG/DSD Series HIGH Volume Pumps; Operation and Maintenance Manual (Document number [029-0020-93-0](#)). For Q-Series, refer to [029-0020-63-0 Muscle Pump manual](#).
2. Clutch Fluid Drain & Gearbox Oil Drain.

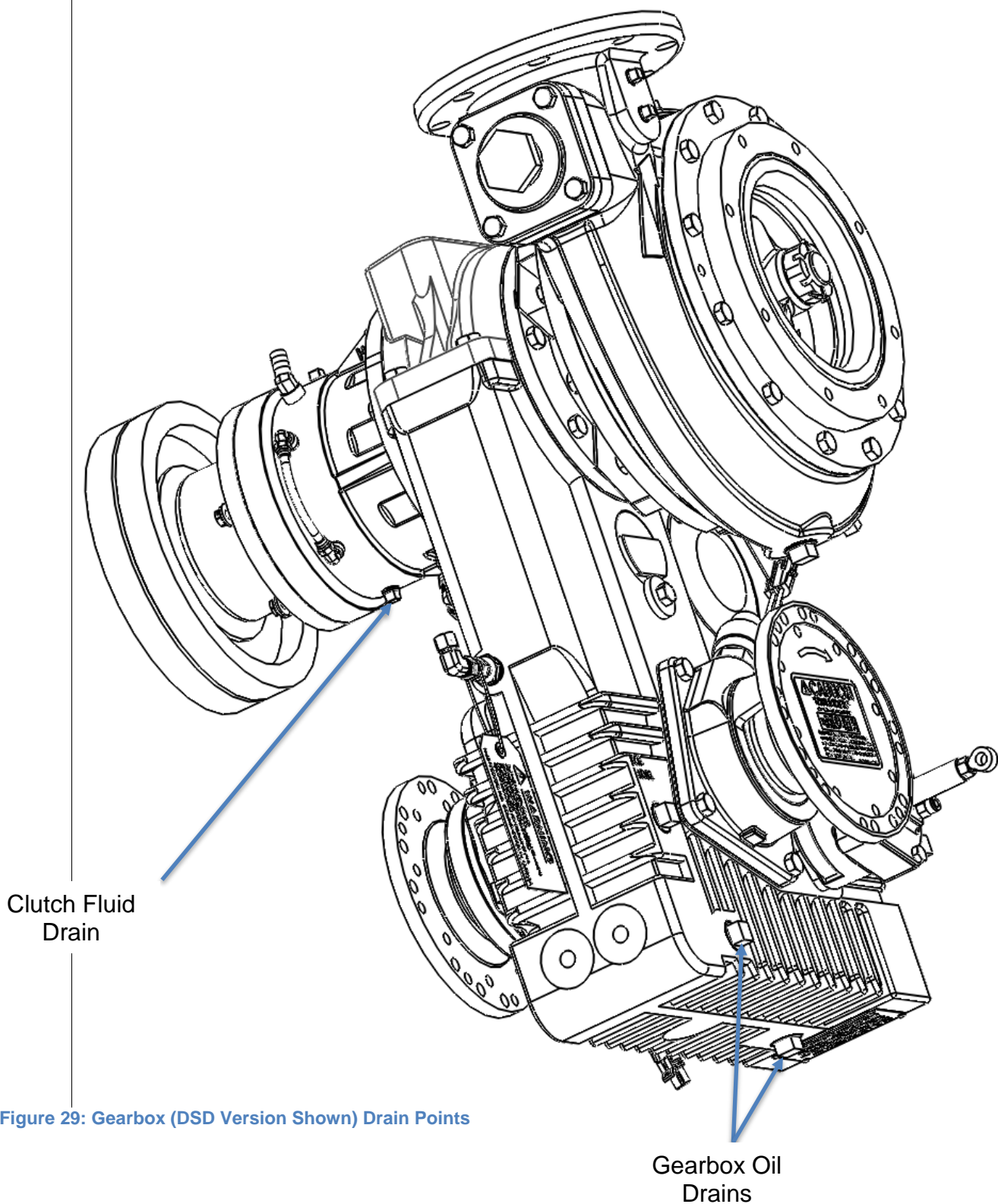
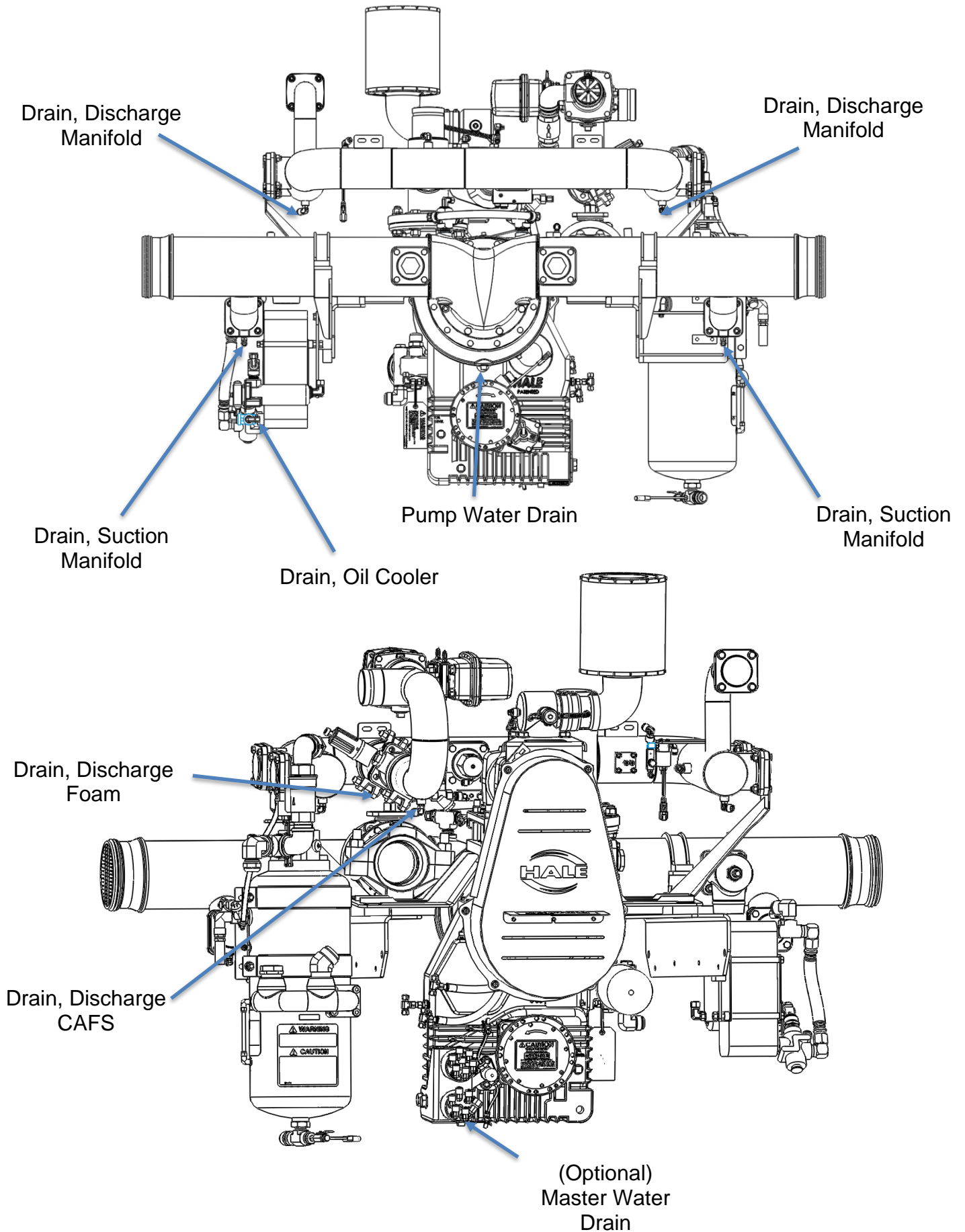

Figure 29: Gearbox (DSD Version Shown) Drain Points

### WATER DRAIN – VOLUTE STYLE





### WATER DRAIN – Q-SERIES

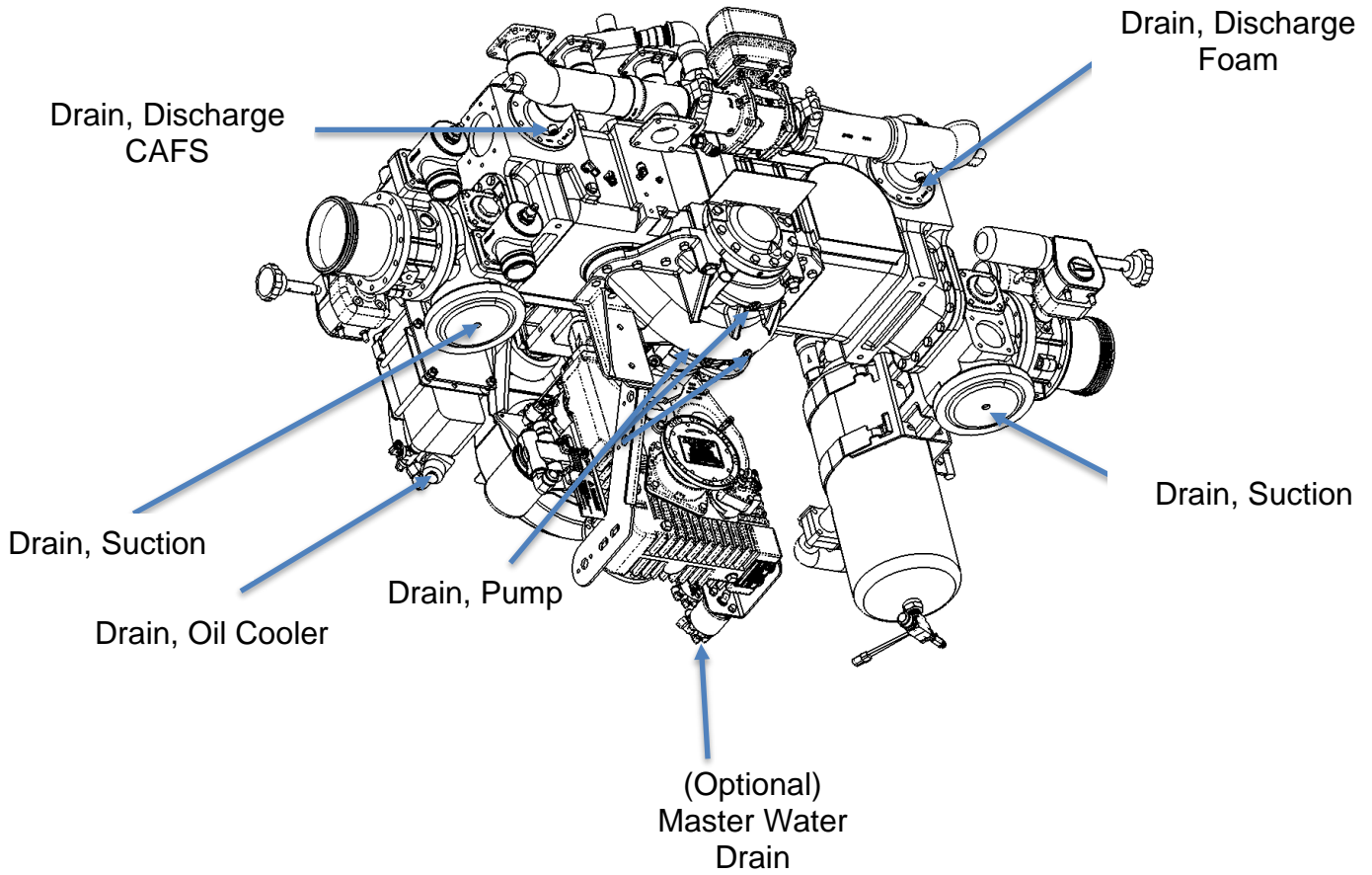

## SYSTEM OIL FILL

### OIL FILLING POINTS

The unit is supplied **without** oil and must be filled with the correct quantity and specification before starting the pump.

### ADDING OIL

Before operating the CAFS system, oil must be added to the pump gearbox and the separator tank.

### GEARBOX

The oil filling point for the Gearbox housing is located as shown.

### GEARBOX OIL FILLING AND CHECKING

Fill the gearbox until the oil flows from the oil fill point. This is the only accurate method of checking that the correct amount of oil has been added to the gearbox, as it allows for different sizes of gear ratios.

- Fill the pump gearbox to the proper level (see [029-0020-63-0 Muscle Pump manual](#) for details). Oil must be SAE EP90, 80W90 or Synthetic 75W-140 gear oil (with an API service rating of GL5).

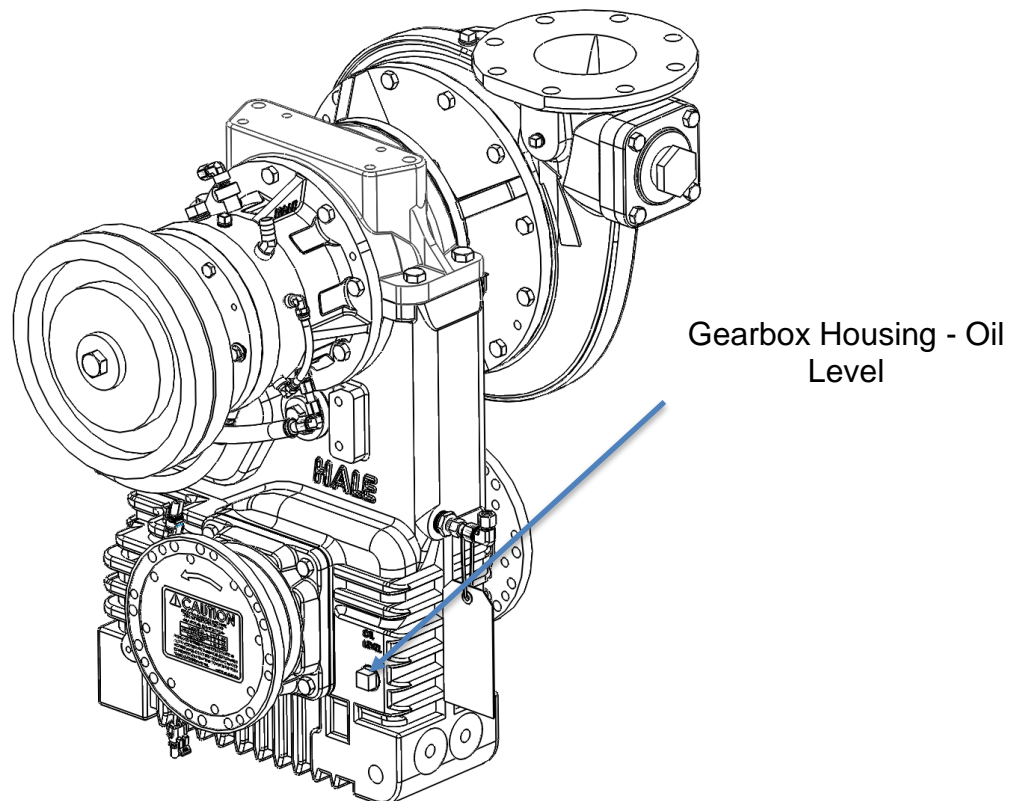

Figure 30: Gearbox Oil Level Check Location (DSD Version Shown)

## OIL SEPARATOR TANK



BEFORE RUNNING THE APPARATUS OR ENGAGING THE PUMP FOR THE FIRST TIME, MAKE SURE THE COMPRESSOR SYSTEM IS FILLED WITH THE APPROPRIATE OIL. AFTER THE INITIAL OIL FILL, ENGAGE THE PUMP AND ALLOW IT TO RUN FOR 10 SECONDS THEN SHUT THE SYSTEM DOWN. ALLOW OIL TO SETTLE, THEN CHECK OIL AND REFILL ACCORDINGLY.

- A heat exchanger is employed to water-cool the compressor, pump and gearbox as the oil passes through.



MAINTAIN A “FULL” OR NEAR-FULL TANK OF WATER TO AVOID OVERHEATING. WHEN THE TANK IS AT “LOW LEVELS” AND OPERATING FOR LENGTHS OF TIME, WITH THE VALVE CLOSED, TANK WATER COULD OVERHEAT.

- Run the pump at IDLE, with the compressor engaged for 30 seconds, then shut it down.
- The oil level should settle within ten minutes to halfway up the sight tube, as noted on the fill decal (See Figure 31).
  - **Recommended:** SAE 15W-40 automotive multigrade oil
  - **Capacity:** 8~9 Quarts [7.5~8.5 litres]

# Separator Tank for Compressor Oil

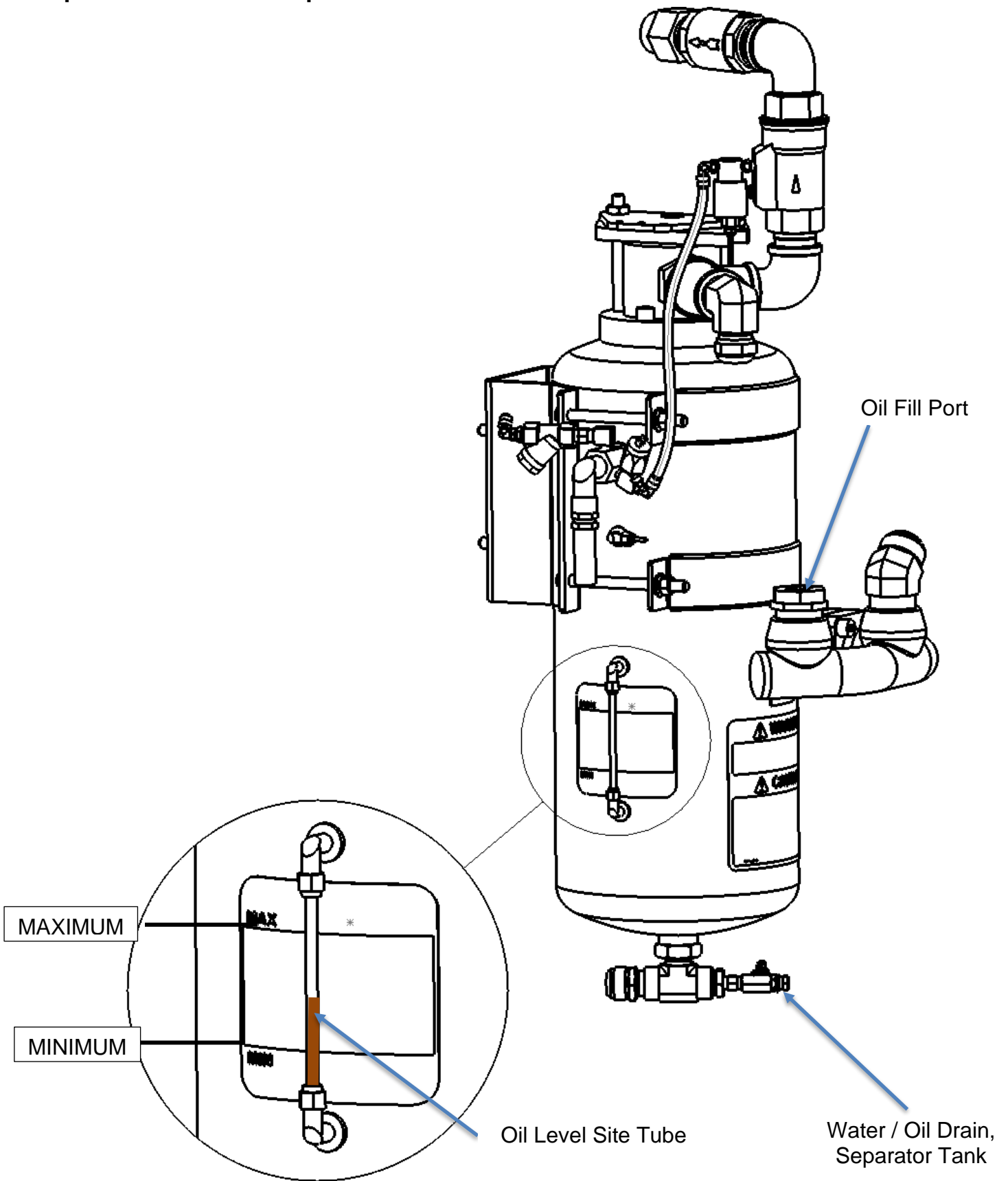

Figure 31: Separator Oil Fill and Drain Identification

- Check system for oil leaks – repair any immediately.
- If no leaks are present and oil level is correct, proceed with foam system calibration.

### HOT-SHIFT CLUTCH HOUSING

- The Hot-Shift clutch housing is shipped from the factory with oil.
- Before operating the CAFS system, check that the oil level sight tube is filled halfway between the top and bottom.
- If needed, fill the front clutch housing to the proper level using Dexron III or Mercon ATF. The front clutch housing holds approximately 12 oz. (0.4 liters) of oil.

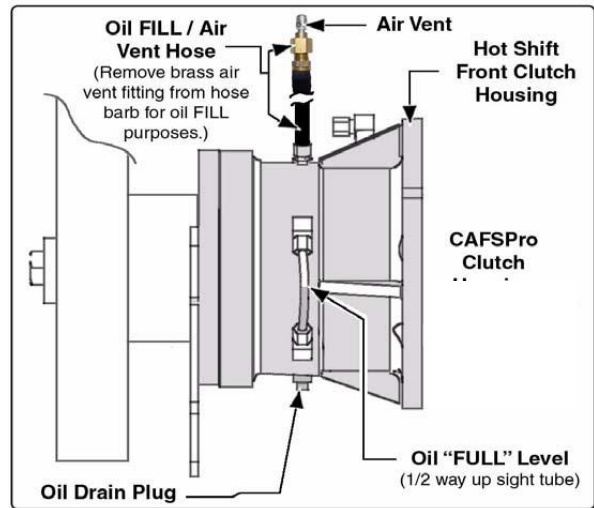

Figure 32: Clutch Component Callout

### CLUTCH FLUID FILLING & CHECKING

1. Remove the plug next to the vent tube in the clutch housing.
2. Remove the vent cap located at the top of the rubber vent tube.
3. Fill the housing through the top of the vent hose until the fluid is at the 1/2 way point in the fluid level indicator tube on the side of the housing.

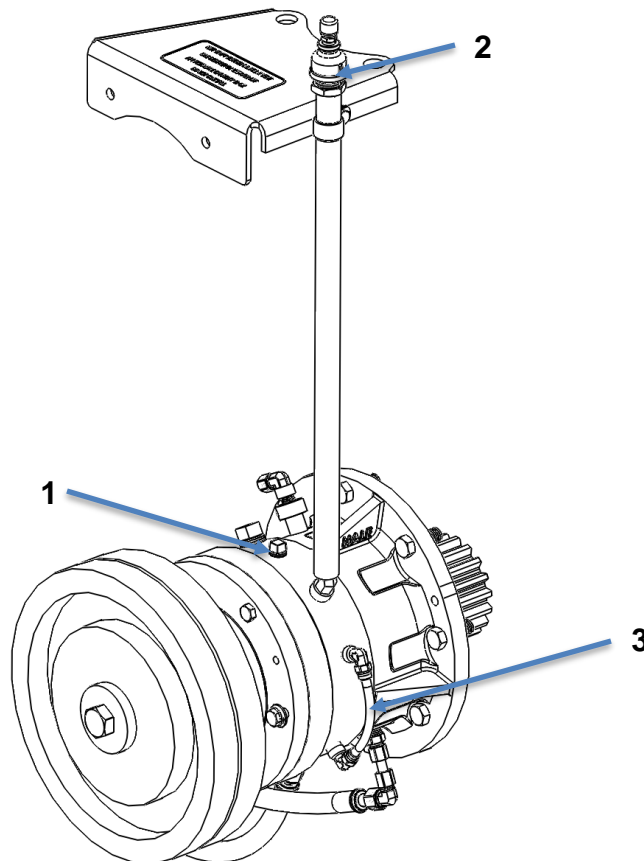
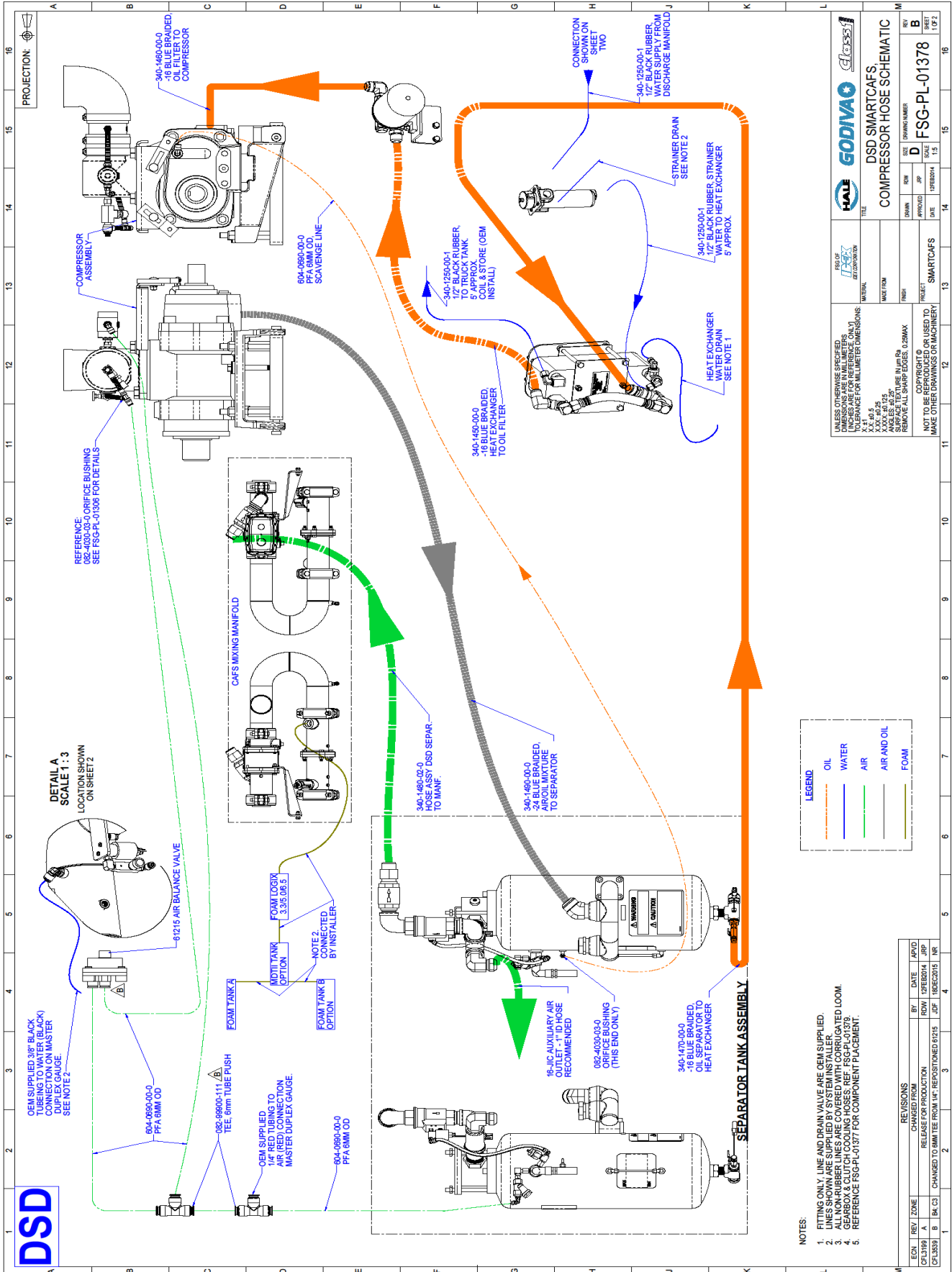
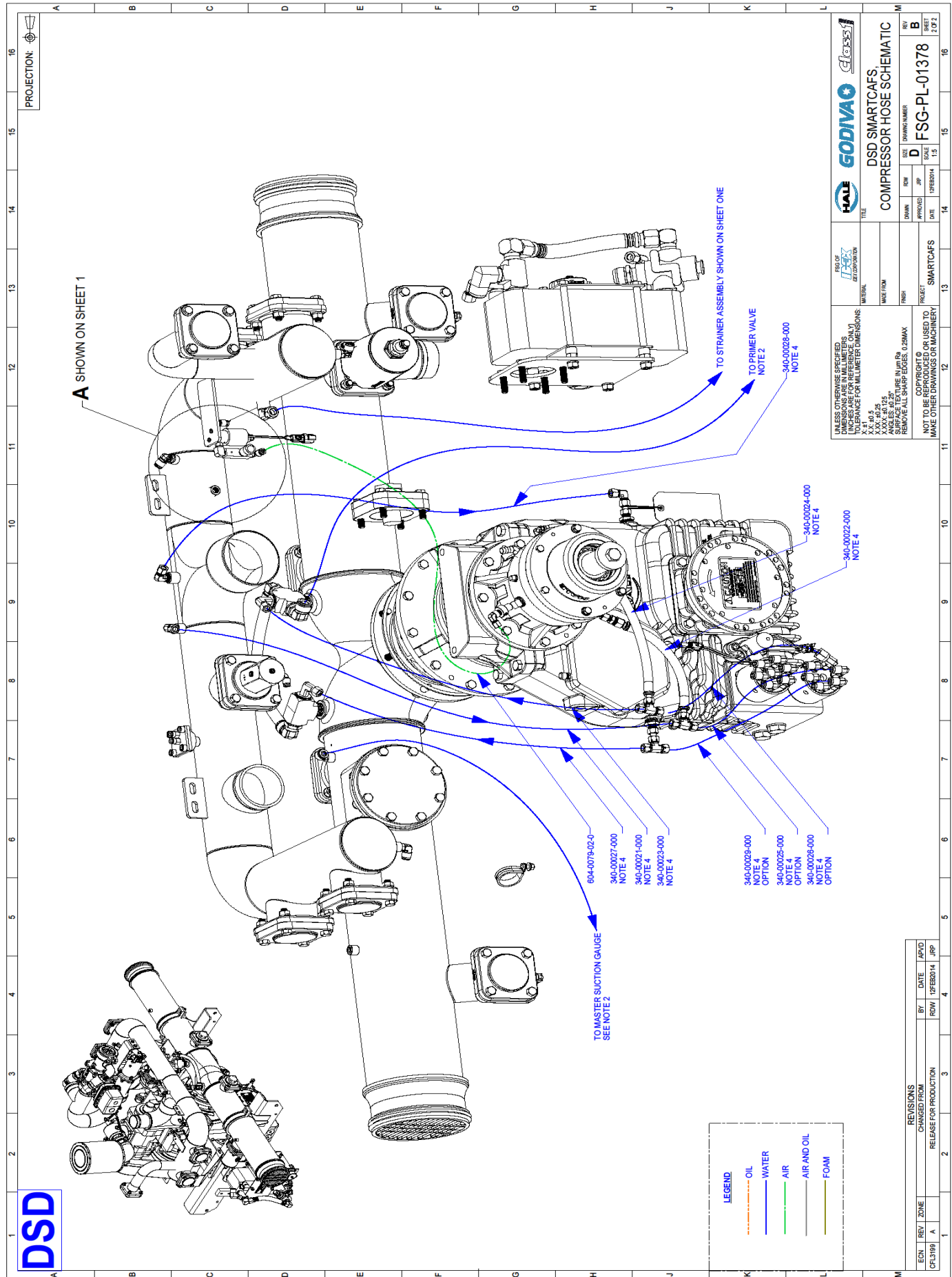

Figure 33: Clutch Fill Point

Schematics

PLUMBING CONNECTIONS – DSD





DIMENSIONS UNLESS SPECIFIED ARE IN INCHES. DIMENSIONS FOR MILLIMETER DIMENSIONS ARE FOR REFERENCE ONLY. DIMENSIONS FOR MILLIMETER DIMENSIONS ARE IN PARENTHESES.		UNLESS OTHERWISE SPECIFIED, DIMENSIONS ARE IN MILLIMETERS. DIMENSIONS FOR REFERENCE ONLY. DIMENSIONS FOR MILLIMETER DIMENSIONS ARE IN PARENTHESES.	
X.X, .01 X.XX, .015 X.XXX, .0125 SURFACE TEXTURE IN $\mu m Ra$ REMOVE ALL SHARP EDGES, 0.25MAX.		COPYRIGHT © NOT TO BE REPRODUCED OR USED TO MAKE OTHER EQUIPMENT.	
FILE DSD SMARTCAFS, COMPRESSOR HOSE SCHEMATIC	DRAWING NUMBER D FSG-PL-01378	DATE 12FEB2014	REV B
DRAWN JPP	ROW D	DATE 12FEB2014	SHEET 1 OF 1

ECN	REV	ZONE	REVISIONS	CHANGED FROM	BY	DATE	APPROVED
CFL3199	A		RELEASE FOR PRODUCTION		ROW	12FEB2014	JPP

PLUMBING CONNECTIONS – Q-SERIES

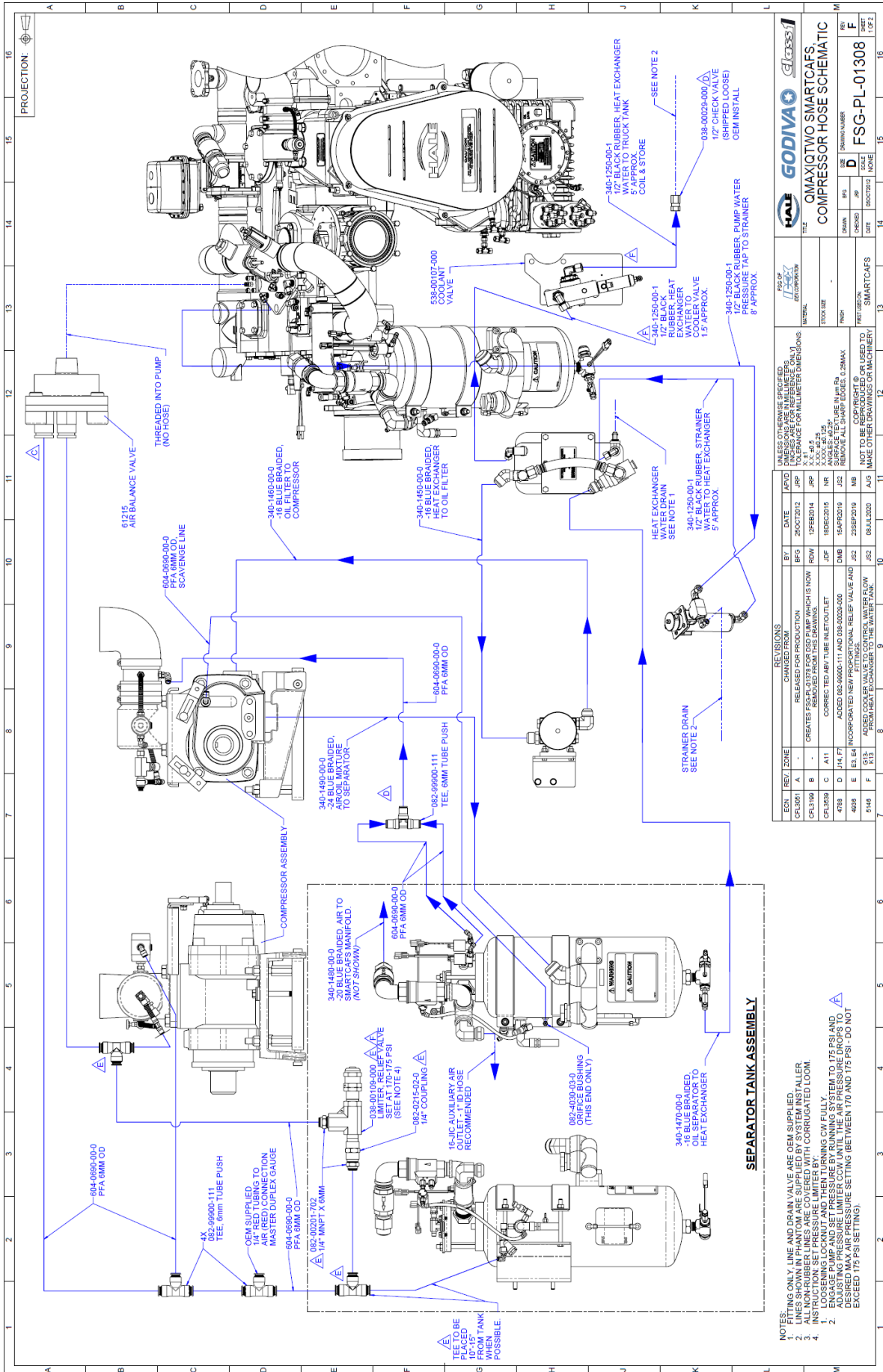

ECN	REV	ZONE	DATE	BY	APPROVED	CHANGED FROM
CP1301	A	-	28OCT2012	JRP	JRP	RELEASED FOR PRODUCTION
CP1309	B	-	12FEB2014	ROW	ROW	CREATES FSG-PL-01308 FOR DSD PUMP WHICH IS NOW X.S. 4.5
CP1493	C	A11	18DEC2015	JDF	MR	CORRECTS AIR TUBE INLET/OUTLET X.S. 4.5, 4.5, X.S. 4.5, 4.5
4793	D	JUN.FT	15APR2019	DMB	JSS	ASSESSES 082-59900-111 AND 082-59900-605 SURFACE TEXTURE IN JUNE 19
4808	E	ESL.E4	23SEP2019	MB	JSS	INCORPORATED NEW PROTECTIVE RELIEF VALVE AND FITTINGS
5148	F	9.13	08JUL2020	AUG	JSS	REVISION TO BE USED TO THE WATER TANK AND HEAT EXCHANGER TO THE WATER TANK

DATE	BY	REVISION
08JUL2020	AUG	SMARTCAFS

UNLESS OTHERWISE SPECIFIED, DIMENSIONS ARE IN MILLIMETERS (INCHES IN PARENTHESES). TOLERANCES FOR MILLIMETERS DIMENSIONS:

FRACTION	TOLERANCE
1/16"	+0.10
1/8"	+0.15
3/16"	+0.20
1/4"	+0.25
3/8"	+0.30
1/2"	+0.35
5/8"	+0.40
3/4"	+0.45
1"	+0.50

REMOVE ALL SHARP EDGES; 0.25 MAX SURFACE TEXTURE IN JUNE 19

NOT TO BE COPIED, REPRODUCED, OR USED TO MAKE OTHER DRAWINGS OR MACHINERY

**REVISIONS**

DATE: 08JUL2020  
 BY: AUG  
 APPROVED: SMARTCAFS

**HALE GODIVA**

QMAXIQTWO SMARTCAFS.  
 COMPRESSOR HOSE SCHEMATIC

REV: FSG-PL-01308  
 1 OF 2

**NOTES:**

- SETTING ONLY. LINE AND DRAIN VALVE ARE OEM SUPPLIED.
- PHANTOM LINES SHOWN IN PHANTOM ARE COVERED BY SYSTEM INSTALLER.
- ALL NON-RUBBER LINES ARE COVERED WITH CORRUGATED LOOM.
- IN LOOSENING LOCKWIT AND THEN TURNING CW FULLY. ENGAGE PUMP AND SET PRESSURE BY RUNNING SYSTEM TO 175 PSI AND DESIRED MAX AIR PRESSURE SETTING (BETWEEN 170 AND 175 PSI - DO NOT EXCEED 175 PSI SETTING).



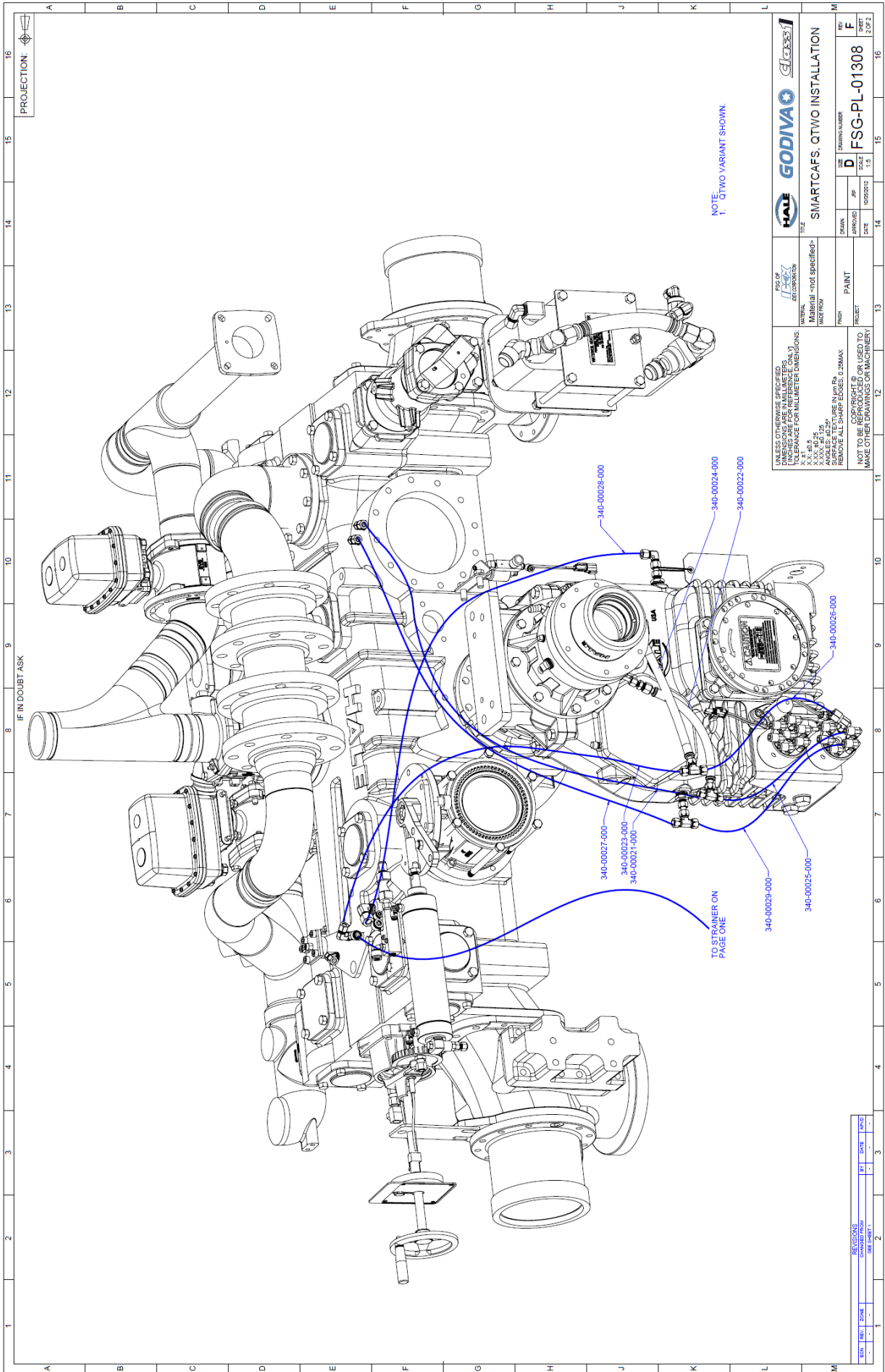

NOTE:  
1. QTWO VARIANT SHOWN.

<b>SMARTCAFS QTWO INSTALLATION</b>	
PART NUMBER <b>FSG-PL-01308</b>	REV <b>F</b>
DRAWING NUMBER <b>D</b>	DATE 03/25/12
APPROVED BY [Signature]	PROJECT PAINT
MATERIAL SIZE	FINISH PROJECT
FINISH OF INTERIOR EXTERIOR	FINISH PROJECT
UNLESS OTHERWISE SPECIFIED, DIMENSIONS ARE IN MILLIMETERS. TOLERANCE FOR MILLIMETER DIMENSIONS: X.X X.XX X.XXX ANGLES: 45° 25° REMOVE ALL SHARP EDGES: 0.2MM MAX. MAKE OTHER DRAWINGS OR MACHINERY.	

REV	DATE	BY	DATE	BY

# SMARTCAFS200 INTERCONNECTION DIAGRAM – DSD

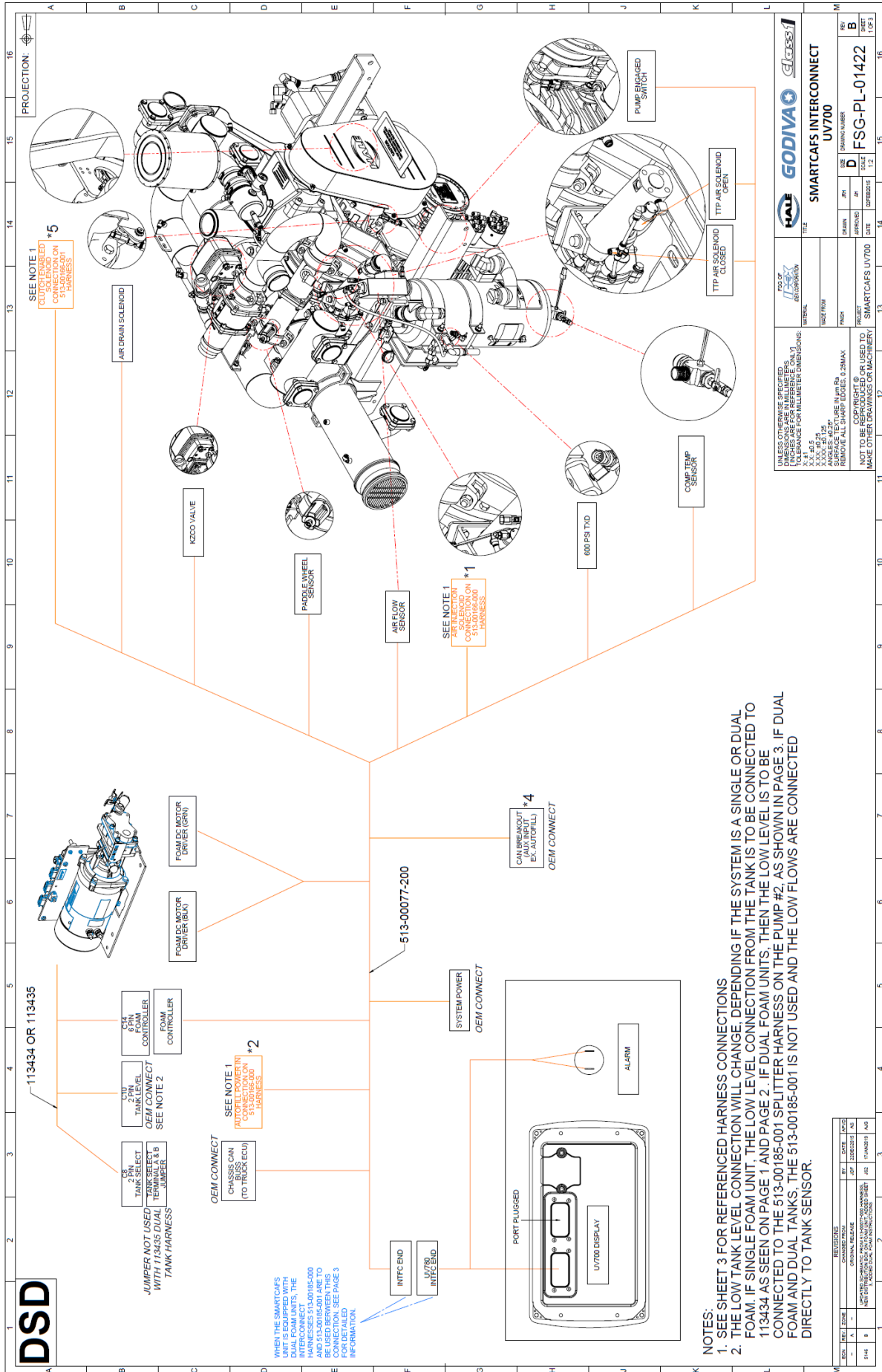

**SMARTCAFS200 INTERCONNECTION DIAGRAM – Q-SERIES**

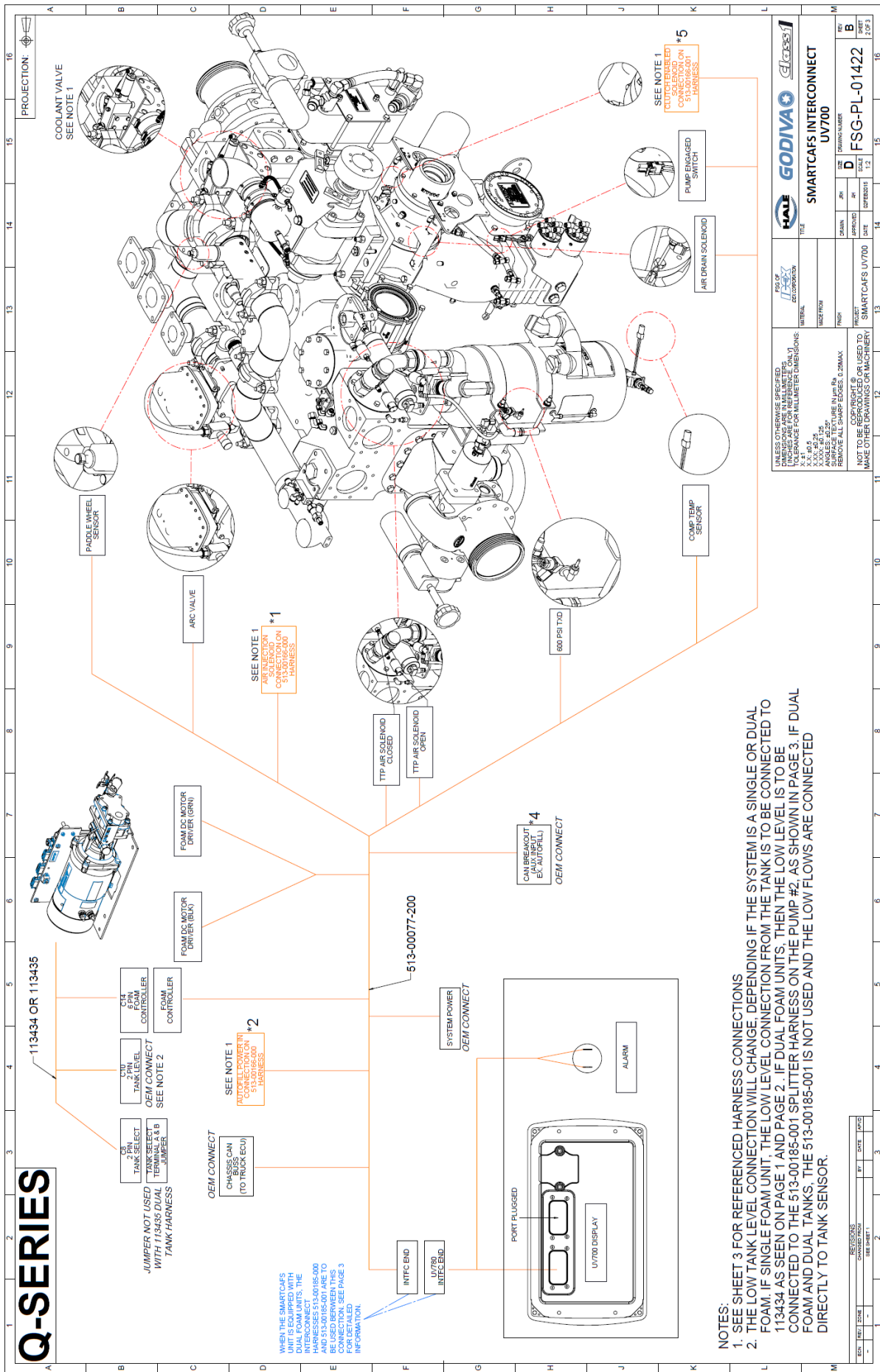

**NOTES:**  
 1. SEE SHEET 3 FOR REFERENCED HARNESS CONNECTIONS.  
 2. THE LOW TANK LEVEL CONNECTION WILL CHANGE, DEPENDING IF THE SYSTEM IS A SINGLE OR DUAL FOAM. IF SINGLE FOAM UNIT, THE LOW LEVEL CONNECTION FROM THE TANK IS TO BE CONNECTED TO 113434 AS SEEN ON PAGE 1 AND PAGE 2. IF DUAL FOAM UNITS, THEN THE LOW LEVEL IS TO BE CONNECTED TO THE 513-00185-001 SPLITTER HARNESS ON THE PUMP #2, AS SHOWN IN PAGE 3. IF DUAL FOAM AND DUAL TANKS, THE 513-00185-001 IS NOT USED AND THE LOW FLOWS ARE CONNECTED DIRECTLY TO TANK SENSOR.

**Q-SERIES**

UNLESS OTHERWISE SPECIFIED, DIMENSIONS ARE IN INCHES AND DECIMAL FRACTIONS ARE FOR REFERENCE ONLY. DIMENSIONS FOR MOUNTING SURFACES ARE IN MILLIMETERS. X .125 .25 .5 .75 1.0 ANGLES: 45° 90° REMOVE ALL SHARP EDGES: 0.25 MAX.		PROJECT: SMARTCAFS UV700 DRAWN: [blank] APPROVED: [blank] DATE: [blank]
PART NUMBER: 513-00185-001 REV: 1		DRAWING NUMBER: SMARTCAFS INTERCONNECT UV700 REV: B DATE: [blank]
PROJECT: SMARTCAFS UV700	SHEET: 43 OF 47	SHEET: 1 OF 1

# SMARTCAFS200 INTERCONNECTION DIAGRAM – ALL UNITS

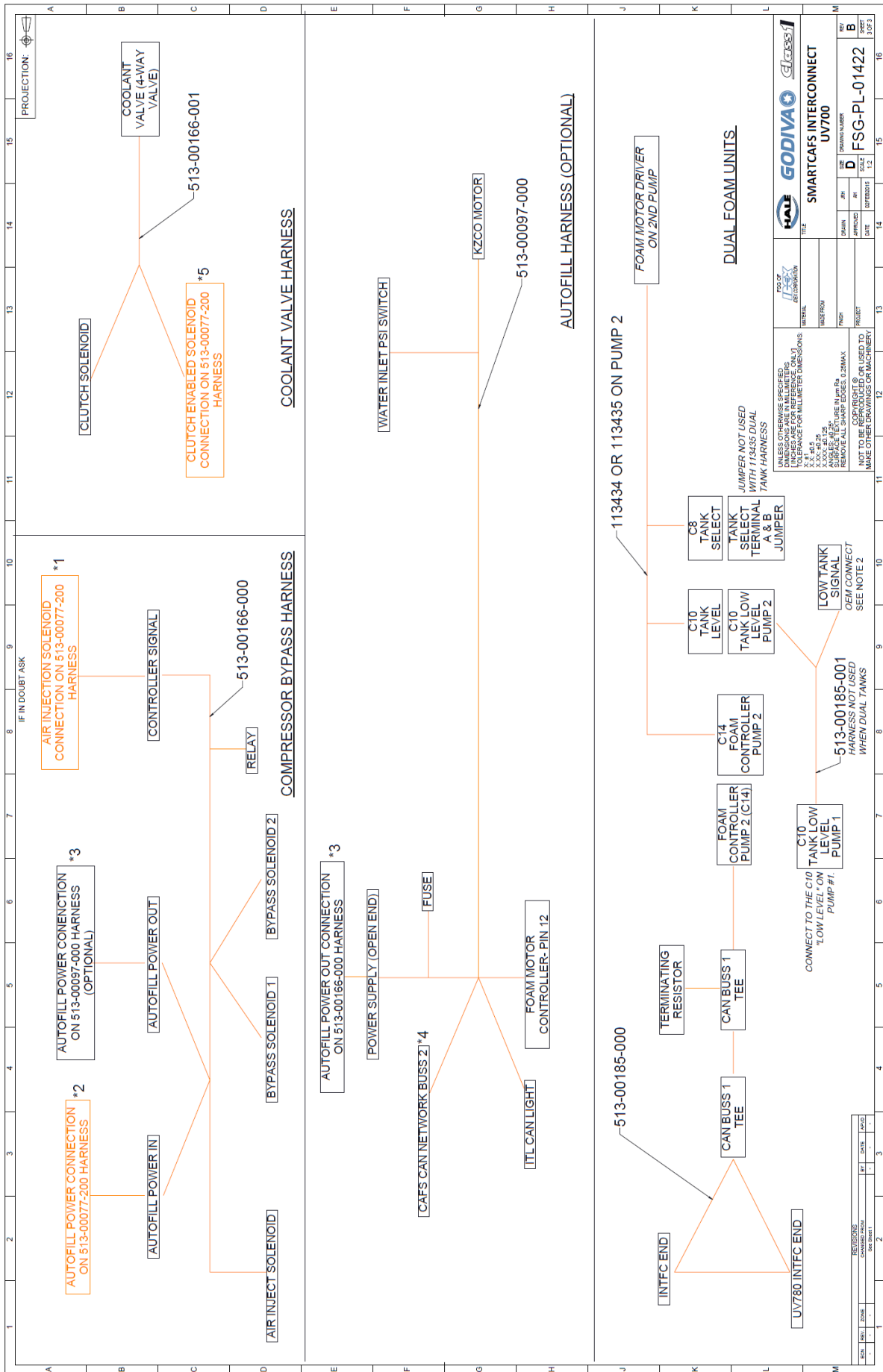

## FOAM TANK LOW LEVEL SENSOR

The unit is supplied with a connector for a low foam level sensor. The sensor is supplied with the unit ready for installation (instructions supplied with the sensor (Hale P/N: 200-2110-02-0)). The low foam level sensor is part of the Safety Interlock system and must be installed.

**Note:** The low foam level sensor must be installed in the tank in the correct orientation. The sensor has an arrow indicating the required orientation and must point upward. The foam tank requires a 1/2" NPT tapped hole for secure mounting of the sensor. The maximum allowable thickness of the tank wall material is 3/4 in [19mm]. The center of the level switch should be located a minimum of 1-1/2 in [40mm] above the foam concentrate outflow to the foam pump.

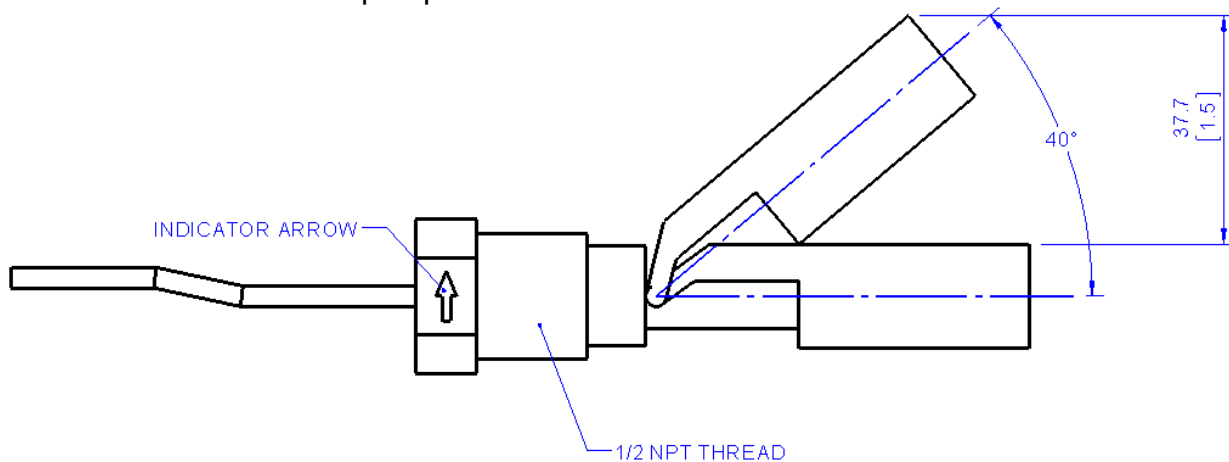

## Additional Installation Points

### FOAM TANK TO FOAM PUMP

The foam feed line must not at any point be lower than the foam pump and be fitted with a valve for maintenance purposes. The isolating tap should be located as close to the tank as possible. A flushing point should be fitted close to the isolating tap to ensure that the maximum length of hose line can be flushed out. The flushing line should also be fitted with an isolating valve.

Foam supply line I.D.	Class A	3/4 in [19mm] minimum
	Class B	1 in [25.4mm] minimum

The foam tank must be located to provide positive head pressure of foam concentrate to the Foam unit, and the supply hose should be arranged to fall gradually from the tank to the foam pump inlet to avoid air pockets. A tank drain valve must also be installed.

The foam tank should be made of plastic or stainless steel, compatible with foam chemicals, with a volume of 6.6 gallons [25 litres] or greater to allow an entire drum of foam agent to be contained. Refer to **Foam unit Model 3.3/5.0/6.5 Manual**.

**Note:** To ensure correct operation of the Foam unit pump, all connections must be secure and pressure tight.

## VEHICLE DESIGN CONSIDERATIONS

The following information is included to assist the vehicle builder to achieve a successful installation.

The in-line foam strainer / valve assembly is a low-pressure device, rated at 43PSI [.296 MPa] and will NOT withstand high flushing water pressure. Refer to Foam unit manual for suggested plumbing layouts.

Seal all electrical power and ground connections with silicone sealant to prevent corrosion.

The system will not operate correctly with poor electrical connections. Verify all electrical connections prior to start up.

Each Hale Foam unit system is tested at the factory using the wiring harness provided. Improper handling and abuse of connections will cause harm and may result in other system damage.

Use fittings which are compatible with those foam concentrates used. Brass or 300 series stainless steel is suitable.

The areas containing the DSD SmartCAFS components must be adequately shielded from the ingress of road spray / debris, chassis and vehicle power train lubricant. Exposure to dirt and grease will have a detrimental effect on the working life of the drive belt and electronics.

Full access to the compressor and gearbox oil fill points and level checkpoints must be considered as well as access for general unit maintenance. The use of removable side panels is advisable.

The compressor oil cooler water return line should have a check valve installed at the point of entry into the truck tank. **PLUMBING CONNECTIONS** – on Page 38. Hale part number 038-00029-000 is recommended for proper operation. Installer is responsible for final connections to the truck tank. Proper draining points to be installed.

To prevent compressed air from being trapped in the pipe work, sealed blank caps **MUST NOT** be used on CAFS discharges.

## COMMISSIONING / START-UP PROCEDURE

1. Check that all the necessary connections have been correctly made.
2. Ensure that the Compressed Air / Oil Separator Tank and pump gearbox are filled with the correct oil type and quantity.
3. Prime and Run the water pump at 125 PSI [0.86 MPa] with compressor engaged.
4. Run the compressor for 30 seconds to allow oil to circulate.
5. Stop unit and check compressor oil level – top up if necessary.
6. Turn the bypass valve on the Foam unit pump to “bypass” and provide a suitable receptacle to collect the foam agent.
7. Ensure that there is sufficient foam agent in the tank(s). For **Foam unit 3.3/5.0/6.5** select tank **A**
8. Select simulated flow on the UV display by pressing the Menu button then pressing the “Simulated Water” button on the screen or button. Then return to the operating screen by selecting the “Return to Operation” button.

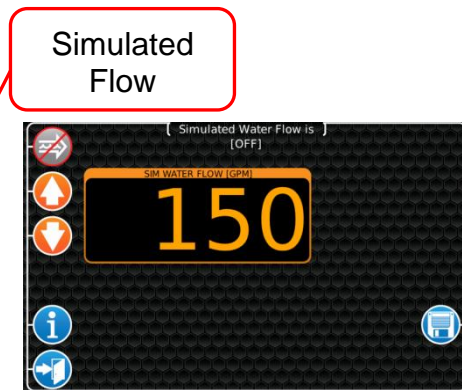
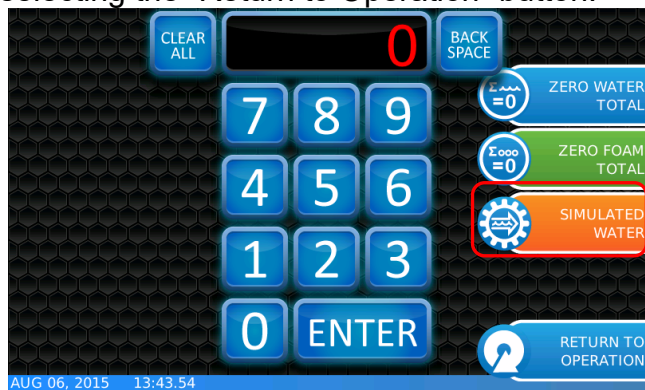

9. Press the  button on the control head, and the Foam unit pump will prime itself. The pump will run for 30 seconds or until prime is achieved. If no prime is made, the display will show a plain test warning. Repeat this step once more to attempt to prime the pump. If priming is not achieved after several attempts, Insure the foam supply is connected and available to the pump.
10. **For 3.3/5.0/6.5 Foam unit**, flush then select tank **B**, and repeat the priming procedure for that tank.
11. When prime is achieved, deselect simulated flow by return to the menu and turning off simulated flow.
12. Return the bypass valve to the inject position.

The unit is now ready to run.

## OPTIONAL TANK SELECTION FOR FOAM UNIT 3.3/5.0/6.5

For specific detail please refer to the **Foam unit Model 3.3/5.0/6.5** Manual: [Installation and Operation manual](#). For further information on the MDTII Manual Tank Selector, please see the separate manual supplied, part number [029-0020-40-0](#).

### DUAL TANK SELECTOR (OPTIONAL)

**Tank A**

For Class A foam concentrate

**Tank B**

For Class B foam concentrate

**FLUSH**

Supplies clean water to flush out foam concentrate from the foam strainer and foam pump

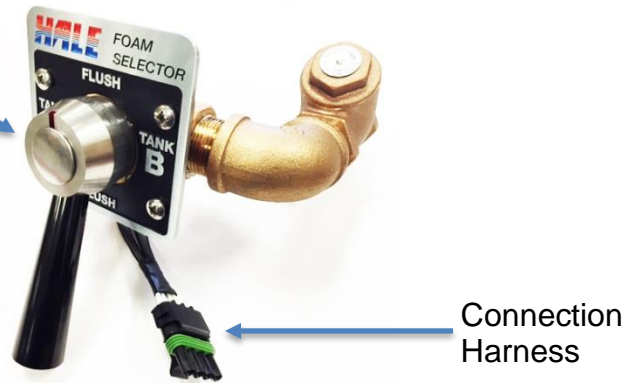



## OPTIONAL MULTI-DISPLAY SETUP/OPERATION

This is the setup and operation guide for the multi-display functionality of the SmartCAFS system. The multi-display feature is designed to work with up to 13 displays that can be placed around the truck to control the CAFS/Foam unit remotely. At any given time, only one display can be used to control the system.



**ALL OEM SETTINGS NOT MENTIONED HERE MUST BE SET THE SAME ON ALL DISPLAYS. THE FOLLOWING SETUP PROCEDURE MUST BE PERFORMED ON EVERY DISPLAY.**

### (a) Setup

1. Access the OEM Configuration menu by entering password 2314 into the password keypad on the menu screen.
2. Scroll down to the second page of the OEM menu. Input the number of displays that the system will be using.

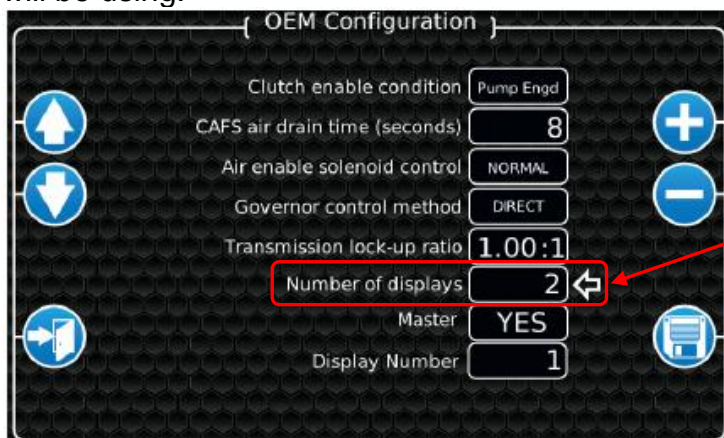

3. If you would like this display to be the default master display, set the MASTER box to YES. **There can only be one master display.** All of the other displays in the system must have a value of NO in this box.

**Note:** Every time the system is restarted, the display that was selected as the default master will always have control first.

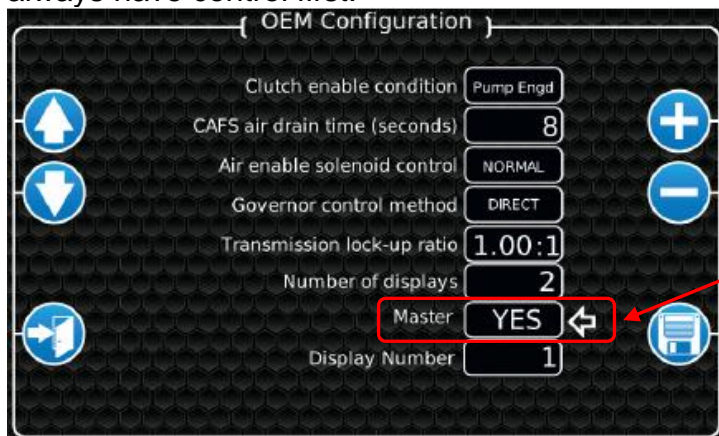

4. Each display must have a number between 1 and the number of displays in the system. **No two displays can have the same Display Number.** The order in which the displays are numbered does not matter.

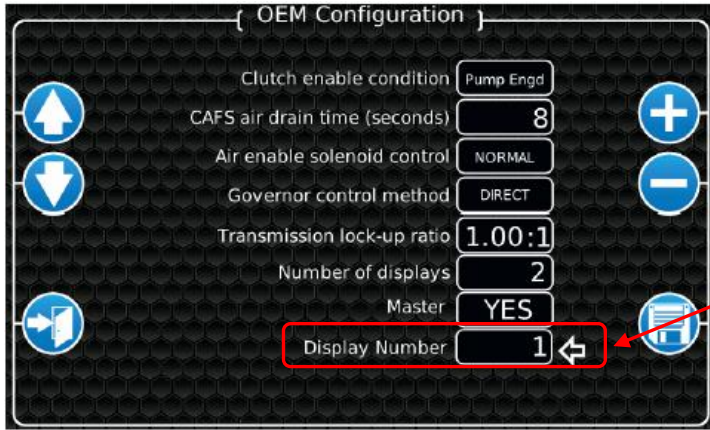

Display Number

- Once you have finished steps 1-4, press the save button. The display that was selected to be the default master will take you back to the home screen, and can be used as normal. The secondary displays will show the screen pictured below.

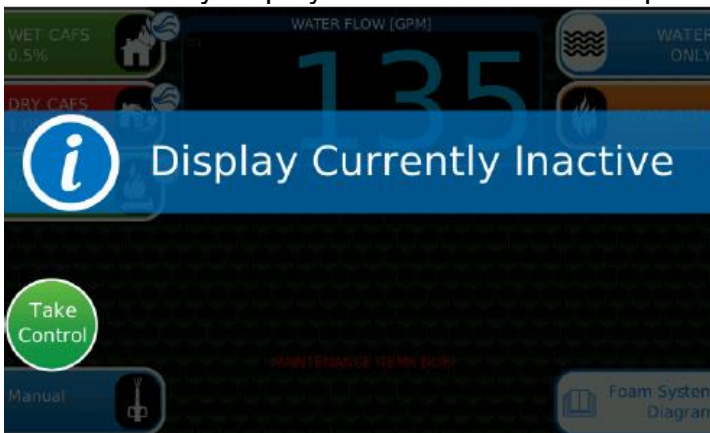

**(b) Operation**

- After the multi-display system is configured, the default master display can be used as normal. All of the secondary displays will remain inactive.
- To take control of the system from one of the secondary displays, hit the Take Control Button (see step 5 of setup).
- If the system is currently not running an operation (Foam/CAFS is turned OFF), the display that took control will bring up the start page and can be used as the main display. The display that was previously the master will now display the screen shown in step 5 of setup.
- If the system is running an operation, the display that took control will be showing the operation screen. This display can now be used to control the operation. The display that was previously the master will now display the screen shown in step 5 of setup.
- If the system is currently in flush, the secondary displays cannot take control. The operator must wait for the flush to finish. When the system is in flush, the secondary displays will show the warning message pictured below.

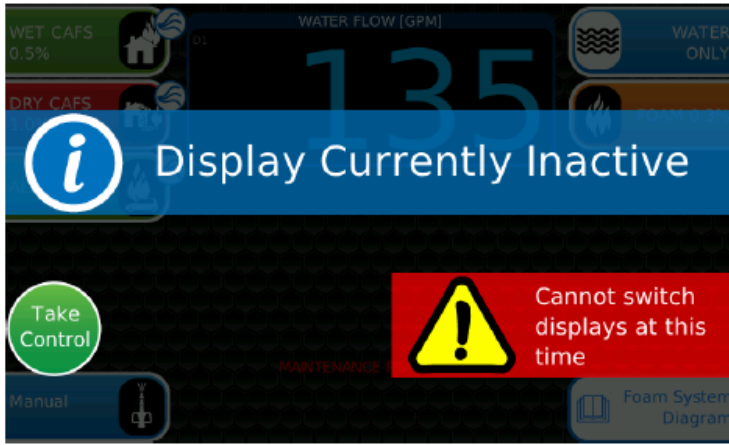

## GENERAL OPERATION



**NEVER USE CAFS WITH A PRESSURE FEED INTO THE EYE OF THE PUMP. SMARTCAFS PUMPS SHOULD ONLY BE USED WHEN WORKING FROM OPEN WATER OR A TANK FEED. PROBLEMS WILL OCCUR WITH THE WATER / AIR PRESSURE RATIO, SHOULD PRESSURISED (HYDRANT) WATER SUPPLY BE APPLIED DIRECTLY TO THE SUCTION TUBE. HYDRANT SUPPLY MAY ONLY BE USED TO MAINTAIN THE WATER LEVEL IN THE VEHICLE TANK.**

### PRESET SCREEN (START SCREEN)

The SmartCAFS Controller shows the start screen after a power cycle. This screen allows the operator to select one of 10 preset operating modes (configurable) or manual operating mode.

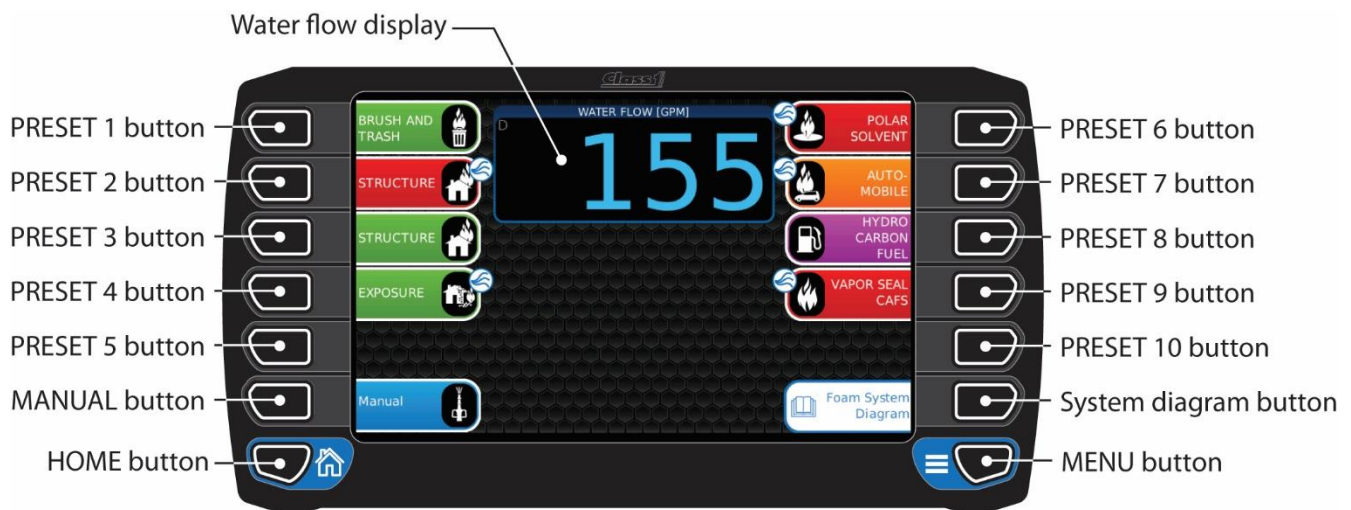

### (c) Preset buttons



There are 10 configurable preset buttons. The text, icon, bar color, and CAFS indicator are configurable by the user through a password protected configuration screen. The preset

configuration screen allows the user to select the operating foam tank (A/B), foam percentage, CAFS mode, and ARC valve position.

The operating screen is entered when a preset button is pressed and held for 0.5 seconds. The operating mode of the foam and CAFS will be set to the configured preset settings.

**(d) Water flow display**

The water flow display is always visible and shows the current water flow rate through the Foam/CAFS discharge manifold.

**(e) Home button**

This button toggles the display between the Preset Screen and the Operating Screen.

**(f) Menu button**

This button shows/hides the additional information displays. When this button is pressed and held for 3 seconds the menu will be displayed.

**OPERATING SCREEN**

The operating screen allows control over the foam, CAFS, and tank valve. The water flow display is always active, but the air flow display is only shown when the CAFS power is ON.

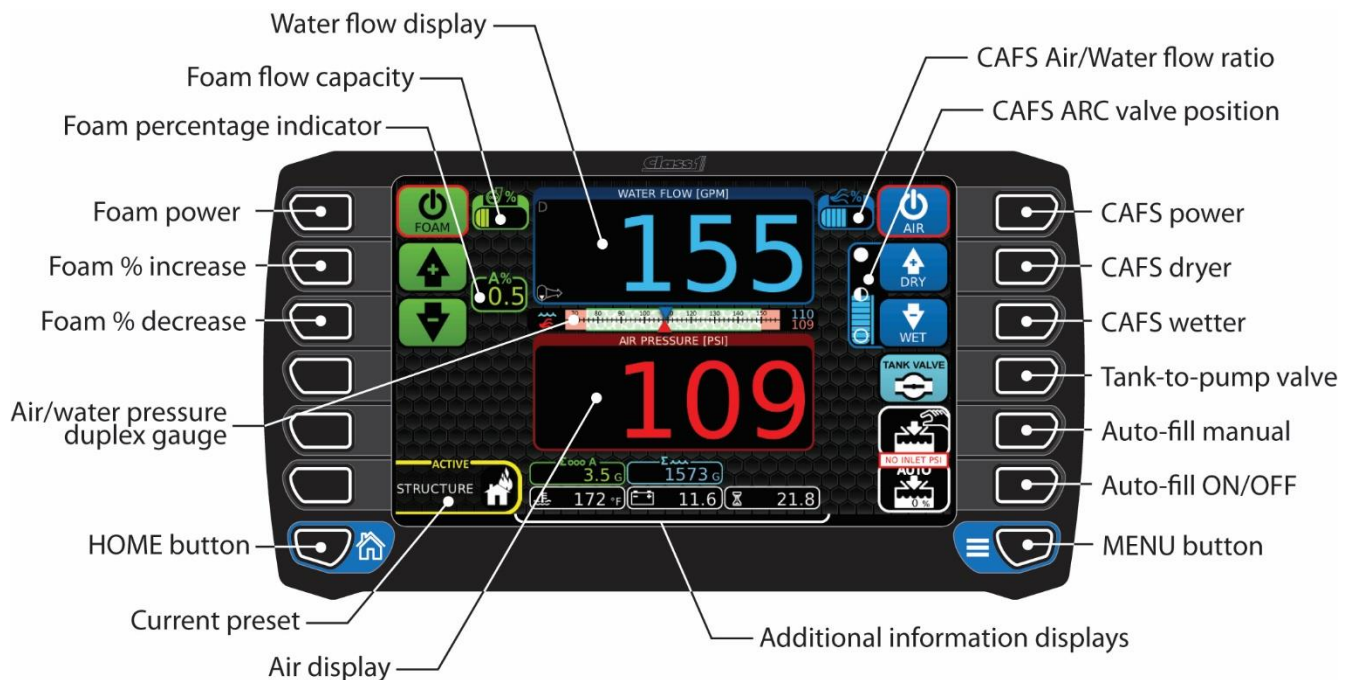

**(g) Water flow display**

The water flow display is always visible and shows the current water flow rate through the Foam/CAFS discharge manifold.

**(h) Foam flow capacity**

The foam flow capacity is a bar graph that shows how hard the foam pump is working (0% to 100%).

**(i) Foam percentage indicator**

The foam percentage indicator shows the foam proportioning rate for the currently selected tank.

**(j) Foam power button**

The foam power button turns the foam system OFF or ON. The foam power button's color indicates the currently selected foam tank (A green, B red, FLUSH orange). The border of the power button is black when OFF and red when ON.



Foam system  
OFF



Foam system  
ON

**(k) Foam increase and decrease buttons**

The increase and decrease foam buttons change the foam percentage for the currently selected foam tank. The color of these buttons indicates the tank selected and foam system power state:

- green = foam system ON, tank A selected
- red = foam system ON, tank B selected
- gray = foam system OFF

These buttons will modify the foam percentage value even when the foam power button is OFF.

**(l) Air/water pressure duplex gauge**

The duplex gauge shows the air and water pressures. The background shows the proper CAFS operating range in green (75 PSI to 150 PSI). This gauge is only shown when the additional information is being shown (see section (x)).

**(m) Home button**

Return to the preset screen.

**(n) Current preset**

This display shows the currently selected preset name and icon (or "manual" if manual was selected).

**(o) Air display**

This display shows the current air pressure, CAFS ratio, or current air flow rate based on the “CAFS air display” selection configured in the “user menu” (see section 0). The air flow rate and CAFS ratio displays are only shown when CAFS is turned ON.

**(p) CAFS air/water flow ratio**

The CAFS air/water flow ratio is a bar graph that shows the relationship between the air flow and water flow rates (0% to 100%). This display is only available when equipped with the Hale air flow sensing valve.

**(q) CAFS ARC valve position**

The ARC valve position indicator is a bar graph that shows the gating of the valve (0% [full wet] to 100% [full dry]). The border color indicates the state of air injection – red = not injecting air, blue = injecting air.

**(r) CAFS power button**

The CAFS power button activates the CAF System (it will start the foam system if it is not already active). CAFS will be turned OFF when the foam power button is turned OFF. The CAF System will also evaluate the air pressure, compressor temperature, water flow, and foam flow before activating the air injection. The border of the power button is black when OFF and red when ON. The power button’s color is gray when the clutch has been disengaged.



CAFS OFF,  
clutch  
disengaged



CAFS OFF,  
clutch engaged



CAFS ON

**(s) CAFS Wet and Dry buttons**

The wet and dry buttons open/close the ARC valve. These buttons are only active when CAFS power is active. These buttons are active when they are blue and inactive when they are gray.

**(t) Tank-to-pump valve button**

The tank valve button opens or closes the tank valve. The icon on the button indicates the current position of the valve (open or closed). The tank-to-pump valve can be configured (in the user menu) to open automatically when the pump engaged signal is detected. Even when set to automatic mode this button can be utilized to manually open/close the tank-to-pump valve.

**(u) Auto-fill manual button**

(When an auto-fill system is installed) The auto-fill manual button opens the KZCO valve connected to the inlet in order to fill the water tank. This button is a momentary button and the valve will only be open as long as the button is held. The on-screen icon changes to green to indicate that the valve is being forced open.

**(v) Auto-fill ON/OFF button**

(When an auto-fill system is installed) The auto-fill ON/OFF button turns ON or OFF the automatic water refill system. The on-screen icon shows the status of auto-fill: white = auto-fill ON, white with RED / = auto-fill is OFF.

The auto-fill system will only operate if there is sufficient inlet pressure (7+ PSI). If there is not enough inlet pressure the “NO INLET PSI” warning will be shown between the buttons.

**(w) Menu button**

Toggle button shows/hides the additional information displays. When this button is pressed and held for 3 seconds it shows the password enter screen.

**(x) Additional information display**

The additional information displays show the total water flowed, total foam flowed, battery voltage, pump engaged operating hours, and compressor oil temperature. This display is toggle ON/OFF with the menu button.

**NOTE:** *Total water flowed and total foam flowed are erased when the system is repowered. These values may also be zeroed during operation when desired in the system menu.*

## FOAM/CAFS OPERATION

### ENGAGE THE PUMP



**WARNING**



**DO NOT APPLY HYDRANT PRESSURE TO PUMP SUCTION WHEN OPERATING CAFS. MAY BE OPERATED FROM OPEN WATER OR TANK FEED ONLY**

**NOTE:** The automatic tank-to-pump open function is a menu selectable item and must be set for “automatic: for this operation to occur (this is the default). The SmartCAFS Controller will automatically open the tank-to-pump valve (see note) when the pump engaged signal is recognized.

**NOTE:** The SmartCAFS Controller will automatically engage the compressor clutch when the pump engaged signal is recognized OR when a CAFS preset button is first pressed. This operation is a menu selectable item. If pump input speed is >900rpm the compressor will not engage and a plain text error message will appear. Reduce speed below 900 RPM then the CAFS compressor can be engaged.

**NOTE:** When discharging dry foam at low pump pressure, the possibility of hose kinking is increased and should be considered when deploying hoses.

### START FOAM/CAFS OPERATION BY SELECTING A PRESET (OR MANUAL)

Press and hold the desired preset button for 0.5 seconds. The display will show an information bar to indicate to keep holding the button for the required time.

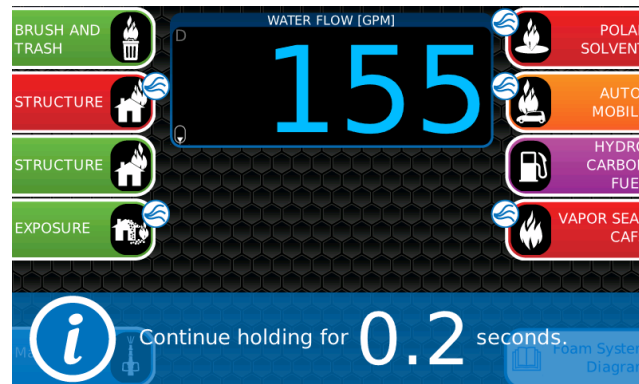

The display will then show the operation screen. The SmartCAFS Controller is now ready to manage the foam/CAF System as the preset dictates when water flow is detected. Water flow is the driving factor for system operation in both “foam only” or “foam and air” (CAFS).





The bottom left corner of the screen shows the currently active preset.

### INCREASE ENGINE SPEED FOR DESIRED WATER PRESSURE

(With Sentry pressure governor) – The SmartCAFS Controller automatically communicates with the Sentry governor to set the governing system to RPM mode and ramp to its preset 1 engine speed.

(Without Sentry pressure governor) – Manually adjust the engine speed to set the water/air pressure to the desired value (CAFS operating range = 75 psi to 150 psi). When using a governor other than the Sentry make sure the governing mode is set to RPM.

### SELECTING A NEW PRESET

If a new preset is desired, press the HOME button to move back to the preset screen.

**NOTE:** *The system continues to operate using the current foam/CAFS setting when going back to the preset screen.*

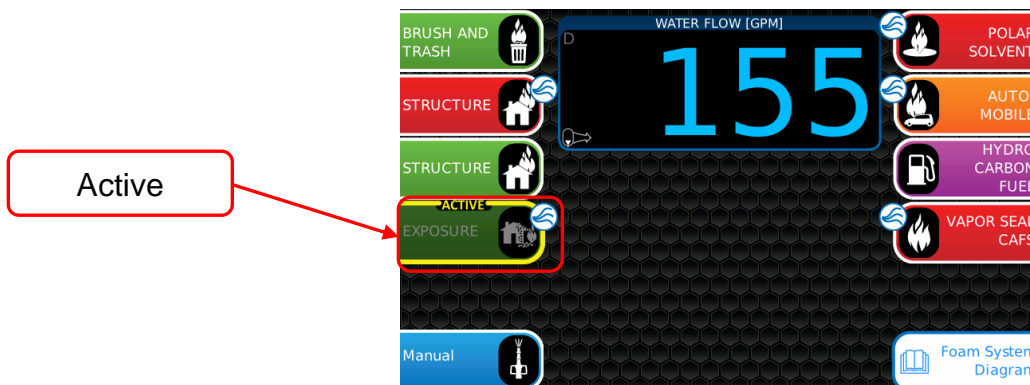

The currently active preset will be indicated by the flashing “ACTIVE” border. Press a new preset button (or manual). Simply press the HOME button again if a new preset is not desired. The operation screen will again be shown.

### MODIFY THE CURRENT OPERATING PARAMETERS

At any time the operating parameters can be modified by pressing the foam percentage (increase/decrease) buttons or by pressing the CAFS wet/dry buttons.

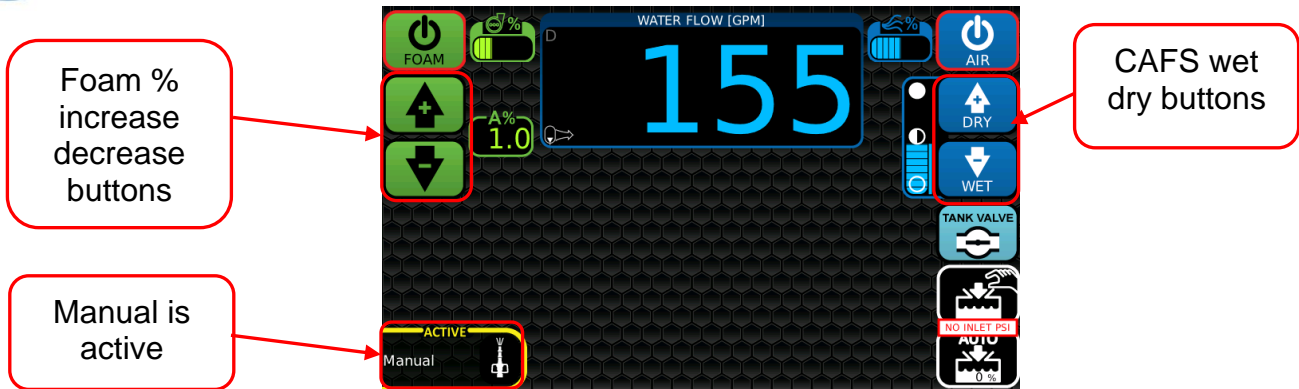

The bottom left corner of the screen will now show “manual” because the settings have been changed from the original preset values.

The foam and/or CAFS power buttons can be pressed to enable/disable the foam/CAF Systems.

- When foam and CAFS are ON, pressing the foam power button will turn OFF foam and CAFS.
- When foam and CAFS are ON, pressing the CAFS power button turns OFF only CAFS.
- When foam and CAFS are OFF, pressing the foam power button will turn ON only foam.
- When foam and CAFS are OFF, pressing the CAFS power button turns ON foam and CAFS.

### DISENGAGING THE COMPRESSOR CLUTCH

1. The compressor clutch will be automatically disengaged when the pump engaged signal is turned OFF. At this time the SmartCAFS Controller will turn OFF foam and CAFS and return to the preset screen.
2. The compressor clutch can be manually disengaged by pressing and holding the CAFS power button for three seconds (the warning banner will pop-up to indicate how long the CAFS power button must be held).

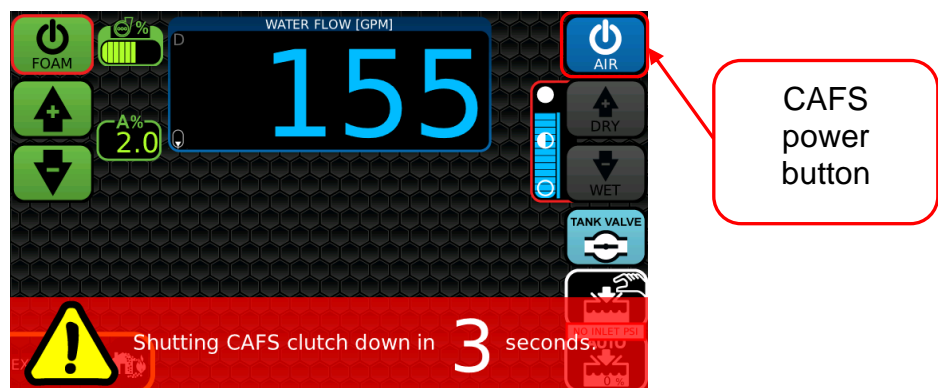

The on-screen CAFS buttons will be gray to indicate that the compressor clutch is disengaged.

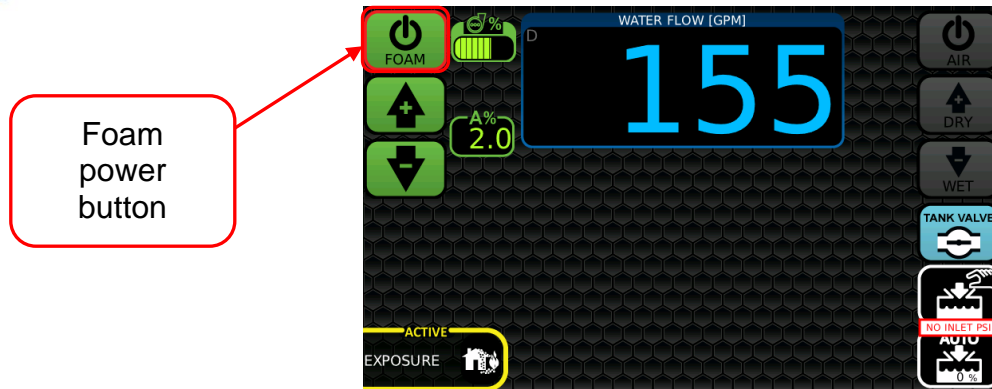

**NOTE:** *It will be necessary to turn OFF the foam system if foam operation is no longer desired.*

3. Run water through the CAFS discharge system to flush out the foam agent.
4. Close the CAFS discharge valves.
5. Shift the truck transmission from DRIVE to NEUTRAL and shift the water pump VPS from PUMP to ROAD mode.
6. If freezing conditions are expected, drain the manifold, pump, water strainer and CAFS heat exchanger.

### OVERHEAT SHUT DOWN

1. Should the compressor oil temperature reach 220°F [105°C], a control panel warning indicator will appear on the screen. The compressor can sustain 220°F [105° C] for short periods without damage.
2. If the compressor oil temperature reaches 230°F [110° C], the drive clutch will automatically disengage. This will stop the compressed air supply and only foam/water solution will be discharged. The compressor cannot be re-engaged until the unit has been cooled and the pump input speed is returned to below 900 RPM.
3. The most probable cause of compressor overheating is insufficient cooling water flow.

### FLUSHING

When returning the apparatus to ready condition after using class B foam, the Hale Foam unit foam pump **must** be flushed. This is because some Class B foam concentrates deteriorate rapidly. It is recommended to flush for the preset time in the SmartCAFS.

**NOTE:** *Approved class A foam concentrates do not deteriorate at the rate of class B foam concentrates. Provided that an approved class A foam concentrate is used and the system is used within 30 days, flushing is not required. After class B foam concentrate has been used, flush the system then select class A.*

For detailed flushing instructions, please refer to the **Foam unit Model 3.3/5.0/6.5 Manual** FSG-MNL-00158

## OPTIONAL WATER AUTO-FILL OPERATION

The SmartCAFS water Auto-Fill system attempts to maintain the desired water tank level by gating the KZCO valve on the inlet side of the pump. The system is controlled by the SmartCAFS display. The Auto-Fill system gets the tank level information from the Class1 ITL (Intelli-Tank) water gauge.

The Auto-Fill system has two modes of operation: **automatic** and **manual**.

### SYSTEM LAYOUT

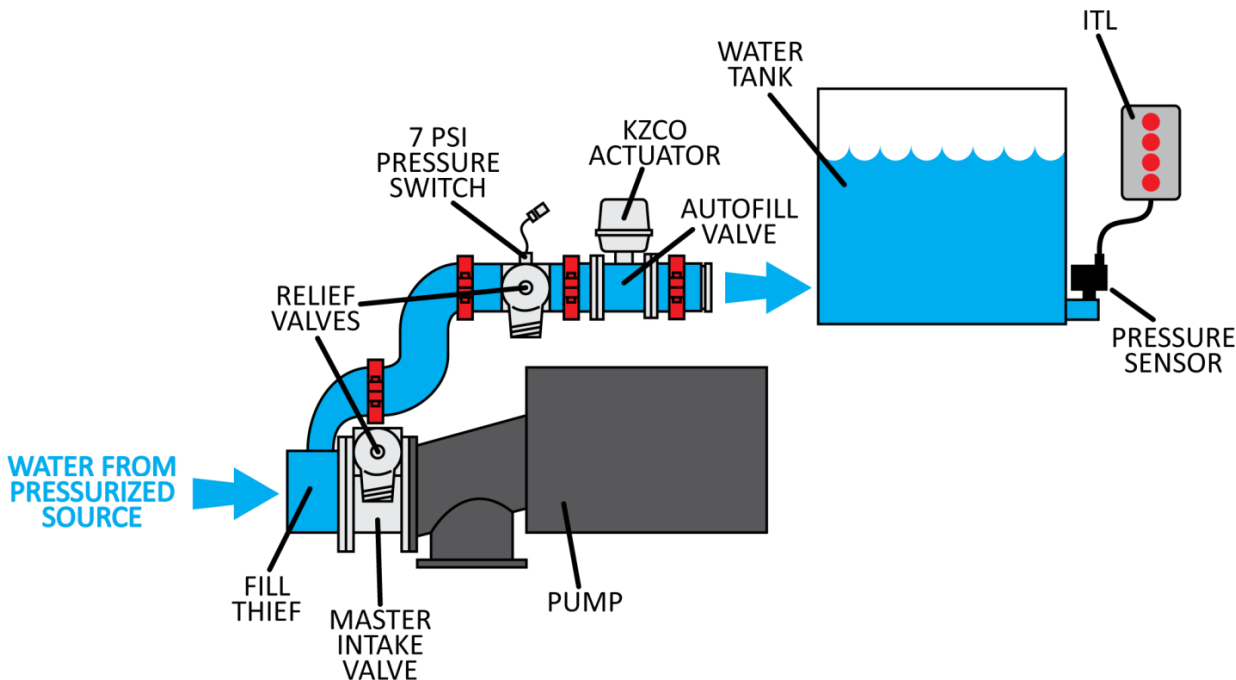

Figure 34: Typical Auto-Fill layout

For wiring harness diagrams and installation, refer to the FSG-PL-01422 documents within this manual (Page 44).

- Connect Power supply (open end) to autofill power out connection on 513-00166-000 harness
- Connect Water Inlet Psi connection to the 7 psi pressure switch
- Connect the KZCO Motor connections to the KZCO Motor
- CAFS CAN Network Bus needs to be connected to CAN Bus 2 (SmartCAFS CAN Network). The harness is designed for one of the connections on this network for be disconnected and plugged into the female connector and the male connector into the open connection you are plugging into.
- Connect the ITL CAN connection and set the ITL to CAN connection mode (see ITL manual for this process)
- Connect the white loose wire to foam motor controller pin12 on the black connector.



<p>TANK B SELECT TANK A SELECT WATER FLOW 1 +9 REF WATER FLOW 2 FOAM SENS DIR</p> <p>AIR DRAIN CLUTCH ENABLE TTP OPEN TTP CLOSE AUTO BYPASS AIR INJECT</p>	<p>COMP TEMP WATER PRESSURE AIR PRESSURE AIR FLOW QTWO MODE AUTO FILL PSI SW</p> <p>TANK A LEVEL TANK B LEVEL WATER LEVEL FOAM PRESSURE +5 REF ANALOG OUT</p>	<p>TANK B LOW FOAM SENS PWR FOAM SENS SIGNAL FOAM SENS GND CAN LOW SUPPLY GROUND</p> <p>TANK A LOW TANK A ACTIVE TANK A ACTIVE CAN SHIELD CAN HIGH SUPPLY POWER</p>	<p>● SYSTEM PWR ● MOTOR PWR ● COM</p>
<p><b>WARNING SURFACE MAY BE HOT</b> </p> <p><b>Class 1</b></p> <p><i>E6-KEY™</i></p> <p><small>607 NW 27th Ave. Ocala, FL 34476 Phone 352 629 5020 FAX 352 629 2902 <a href="http://www.es-key.com">http://www.es-key.com</a></small></p>			

## COMPONENTS

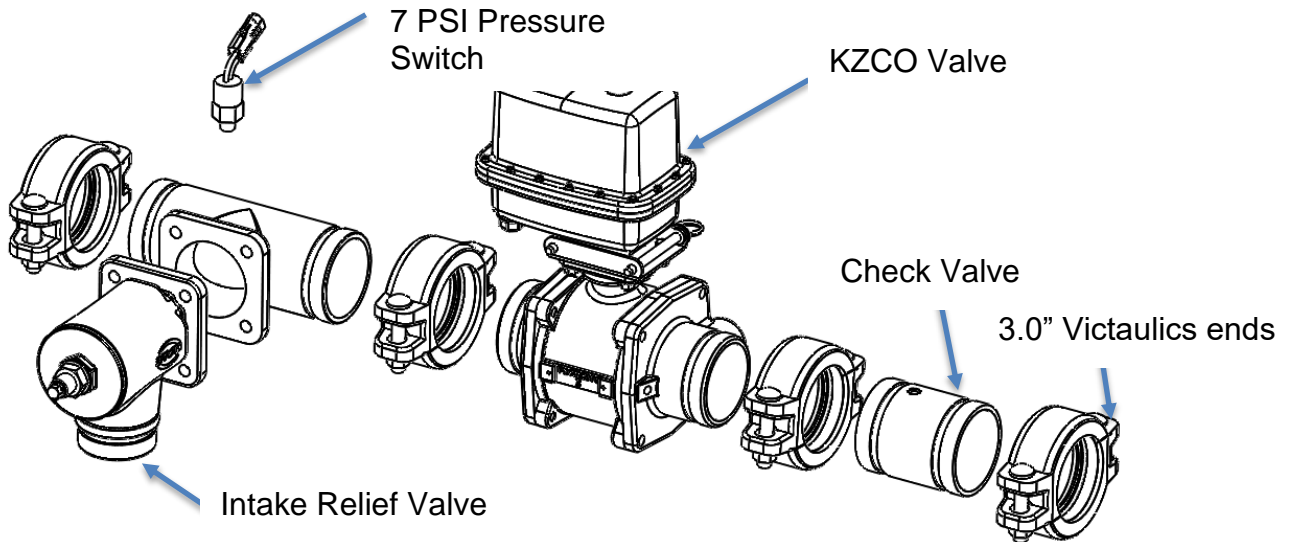
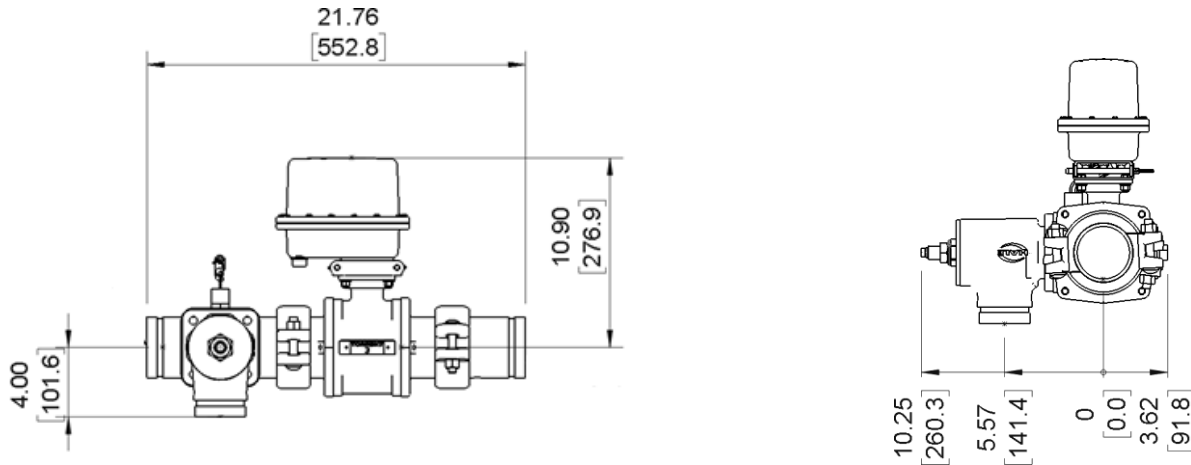

Figure 35: Typical Auto-Fill assembly

Items not shown but included in kit:

- Auto-Fill harness
- 0-5 PSI Pressure Transducer
- Tank Level ITL-4
- ITL-4 Harness

The Auto-Fill Kit comes in 2 sizes, a 2.5" (538-00048-250) and 3.0" (538-00048-300) versions.



### ENABLING AUTO-FILL

The Auto-Fill has to be enabled in the SmartCAFS controller’s USER menu (password **1849**). Set the “Water Autofill enabled?” value to YES.

### START/STOP AUTOMATIC AUTO-FILL

A positive pressure water source (like a hydrant) is require for the automatic Auto-Fill system to operate. The SmartCAFS controller must see the activation of the 7 PSI pressure switch to allow the KZCO actuator to open the Auto-Fill Valve. If the pressure switch is not active, the “NO INLET PSI” warning will be shown.

The SmartCAFS controller receives a CAN message from the ITL indicating the level of water in the tank and determines if the tank is filling or draining. When the Auto-Fill system is set to automatic mode and the tank is determined to be draining (and the 7 PSI pressure switch is active), then the Auto-Fill valve will be slowly opened until the ITL reports that the tank is no longer draining. If the ITL reports that the tank is filling then the Auto-Fill valve will be slowly closed until the ITL reports that the tank is no longer filling.

The current position (0% to 100%) of the valve is shown on the on screen Auto-Fill ON/OFF button during automatic mode.

Press the Auto-Fill ON/OFF button to change the system state.



Auto-Fill  
system OFF



Auto-Fill  
system ON

## MANUALLY OPEN THE AUTO-FILL VALVE

Press the auto-fill manual button to force the valve open. Release the button to close the valve (if the auto-fill system is ON it will revert to the automatic control). A positive pressure water source is NOT required for the Auto-Fill valve to be opened manually.



Manual fill OFF



Manual fill ON

## SETTING THE DESIRED TANK LEVEL FOR AUTO-FILL

The USER menu (password **1849**) contains the setting “Desired autofill water level” which can be set anywhere from “empty” to “full” in 1/8 tank increments (the default is 7/8).

## MENUS

### SYSTEM MENU

Press and hold the MENU button for 3 seconds until the system menu is shown. The system menu allows the clearing (zero) of the total water and total foam display, setting the simulated water flow (for diagnostics), and entering passwords for other menus (user and OEM), for calibrations (water and foam), and for configuration (presets).

**NOTE:** *The password keyboard is greyed out if the foam and/or CAFS power buttons are ON.*



### SETTING THE SYSTEM TIME

Press the blue bar in the bottom left corner of the system menu screen (over the month and day) and the “set the date and time” screen will appear. Enter the new date/time and press the “green check mark” to save.

**NOTE:** *The display will re-boot after pressing the “green check mark”.*

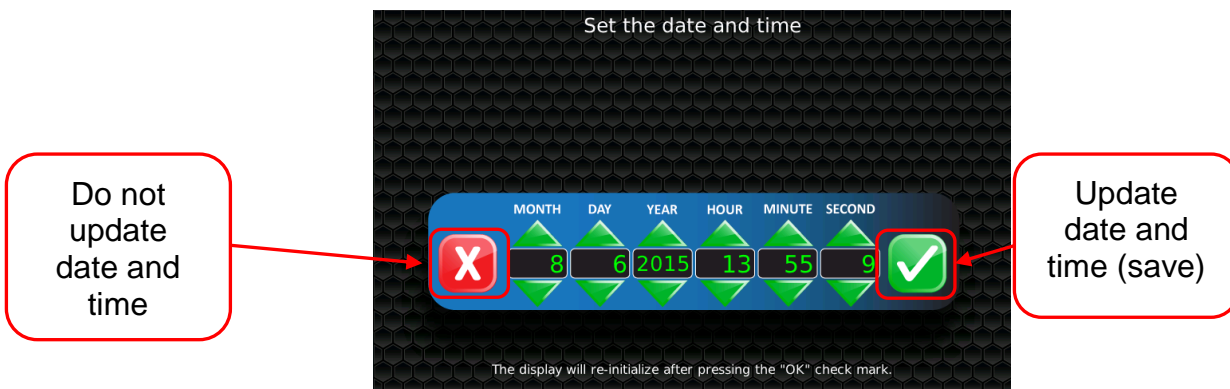



## USER MENU

Enter the password **1849** in the system menu's keyboard to open the user menu. The user menu allows setting of user configurable items.

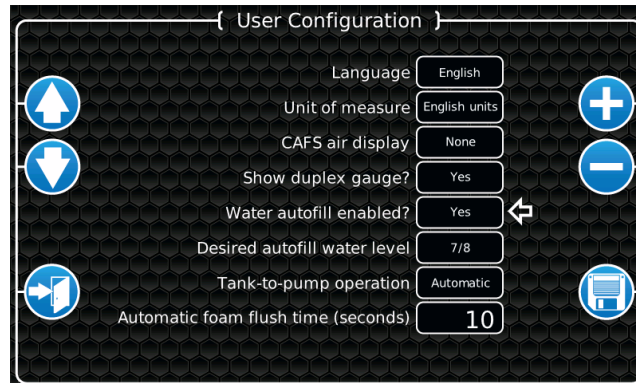

- Language - select the desired language to show within the SmartCAFS Controller.  
**Default: English**
- Unit of measure - select the desired unit of measure for the system (English or metric).  
**Default: English units**
- CAFS air display - select the desired display to be shown for the air. This display is shown beneath the water flow display (none, SCFM, ratio, or air pressure).  
Note: SCFM will only be shown if a Hale air flow sensing valve is installed.  
**Default: None**
- Show duplex gauge? - select whether to show the duplex gauge when additional information is toggled.  
**Default: No**
- Water autofill enabled? - select whether to use auto-fill.  
**Default: No**
- Desired autofill water level - select the level to maintain in auto-fill (fill, 7/8, 3/4, 5/8, 1/2, 3/8, 1/4, 1/8, empty).  
**Default: 7/8**
- Tank-to-pump operation - select whether the tank-to-pump valve is operated manually or automatically (or none if an air actuated tank-to-pump valve is not installed).  
**Default: Automatic**
- Automatic foam flush time - number of seconds that the foam system must be flushed (2 to 60 seconds).  
**Default: 10 seconds**

(y) **UP/DOWN arrow buttons**



Select the menu item. The white arrow points to the currently selected menu item.

(z) “+” and “-“ buttons



Change the value of the currently selected menu item.

(aa) Exit button



Exit the menu.

(bb) Save button



Save all items in the menu.

**OEM MENU**

Enter the password **2314** in the system menu’s keyboard to open the user menu. The user menu allows setting of user configurable items.

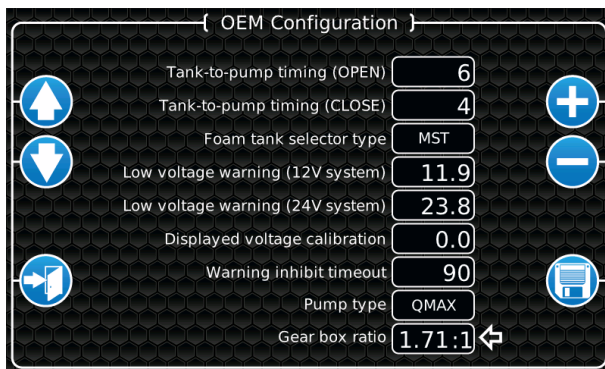

Page one

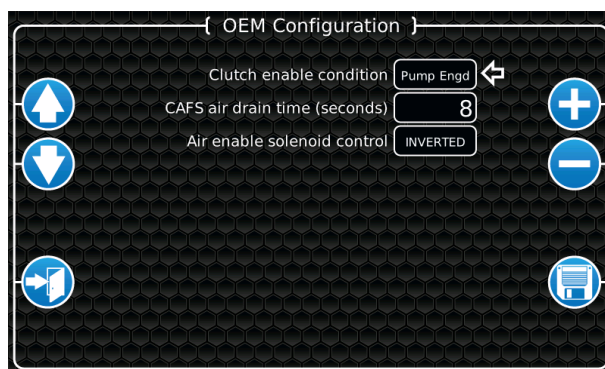

Page two

Tank-to-pump timing (open) - select the amount of time the “open” air solenoid is activated. The tank-to-pump valve is controlled via a linear air cylinder so this setting allows for fine tuning of the amount of time it actually takes to fully stroke the cylinder.

**Default: 6 seconds**

Tank-to-pump timing (close) - select the amount of time the “close” air solenoid is activated. The tank-to-pump valve is controlled via a linear air cylinder so this setting allows for fine tuning of the amount of time it actually takes to fully stroke the cylinder.

**Default: 4 seconds**

Foam tank selector type - select the foam tank selector type. Single tank systems (none or MST), dual tank systems (MDT or ADT).

**Default: MST**

Low voltage warning (12V) - select the low voltage warning level for 12V systems.

**Default: 11.9 volts**

Low voltage warning (24V) - select the low voltage warning level for 24V systems.

**Default: 23.8 volts**

- Displayed voltage calibration - if the displayed voltage in the additional information displays does not match the actual system voltage this value can be adjusted to calibrate (offset) the voltage (-1.5 to +1.5 volts).  
**Default: 0.0 volts**
- Warning inhibit timeout - sets the amount of time (30 to 300 seconds) that a warning, which was inhibited (cleared) by the operator, will stay hidden until it shown again (if the warning is still active).  
**Default: 90 seconds**
- Pump type - select the Hale pump type (QMAX-XS, QMAX, QTWO, or DSD).  
**Default: QMAX-XS**
- Gear box ratio - select the gear box ratio. This is used along with the pump type to set the compressor over-speed warning.  
**Default: 1.71:1**
- Clutch enable condition - select when the compressor clutch will be enabled (Pump Engd = clutch engaged when the pump engaged signal is activated, Preset = clutch engaged when a CAFS preset is first pressed).  
**Default: Pump Engd**
- CAFS air drain time - select how long the air drain solenoid is open when the pump engage signal is deactivated (0 to 10 seconds). This allows the residual air to be bled off after system usage.  
**Default: 8 seconds**
- Air enable solenoid control - sets how the air enable solenoid is controlled. Inverted = air IS NOT blown into the air valve assembly to activate air injection. Normal = air IS blown into the air valve assembly to activate air injection. **Note: when using the Hale air sensing valve this value should be set to "inverted".**  
**Default: INVERTED**

(cc) UP/DOWN arrow buttons



Select the menu item. The white arrow points to the currently selected menu item.

(dd) "+" and "-" buttons



Change the value of the currently selected menu item.

(ee) Exit button



Exit the menu.

(ff) Save button





Save all items in the menu.

## CALIBRATIONS

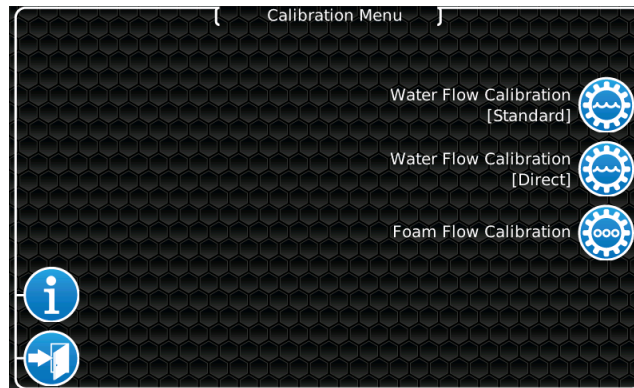
Enter the password **6679** in the system menu’s keyboard to open the calibration menu. The calibration menu allows the foam and water calibrations to be performed.



**NOTE:** Anytime the  button is shown it can be pressed to pop-up a tutorial about the current screen. The tutorial can be canceled at any time by pressing the  button again.

### WATER FLOW CALIBRATION (STANDARD)

The standard water flow calibration requires plain water to be flowed through a foam/CAFS capable discharge. The water flow calibration requires flows at a high rate and a low rate. The high and low rate is determined by the person calibrating the system. This two-point calibration yields a very precise water flow calibration across the entire range.

**NOTE:** An accurate flow measuring device must be used to measure the water flow when calibrating the flow sensor. Use a suitable size, smooth bore nozzle and an accurate Pitot Gauge instrument.

1. Establish flow through a foam/CAFS capable discharge at either the high or low rate. Use the yellow “raw pulses” display window to verify that the paddlewheel sensor is detecting the water flow.

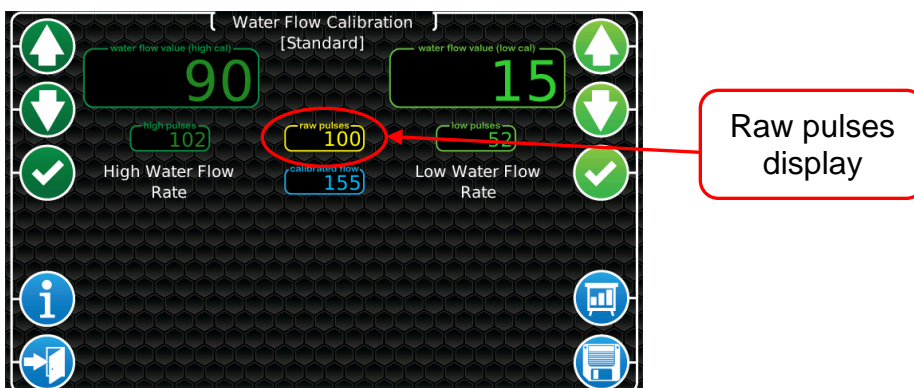

2. Press the “chart icon” button to open the flow rate calculator.

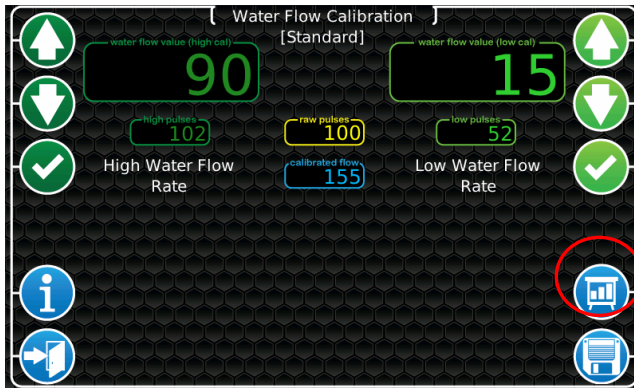
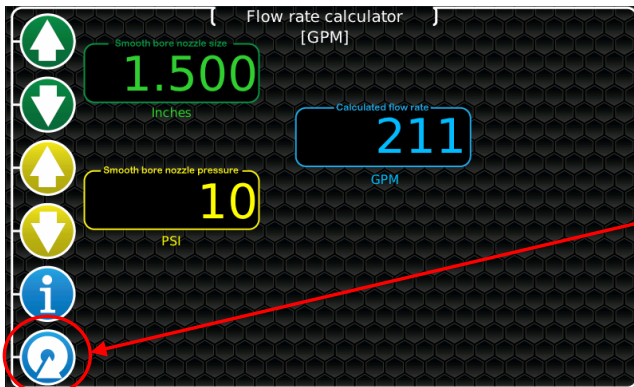

Chart icon

3. This calculator will allow the entry of the smooth bore nozzle size and the current pitot gauge reading in order to calculate the flow rate. Press the “return arrow icon” button to return to the water flow calibration screen.



Return  
arrow icon

4. The display will ask where you want to place the calculated value. Press the display where you want the value to be placed.

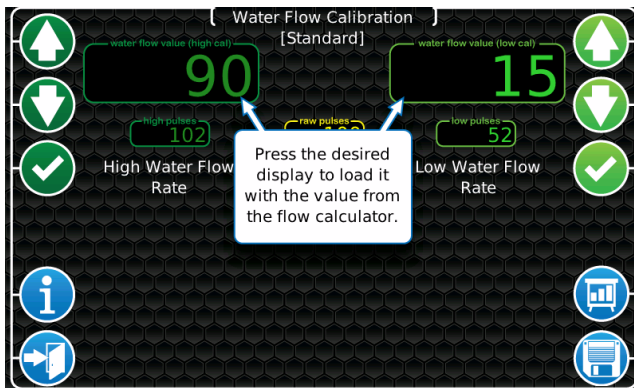

5. Press the “check mark” button on the desired side (high or low). Make sure that the value in the yellow “raw pulses” display window is now in the green “high pulses” (or “low pulses”) display window.

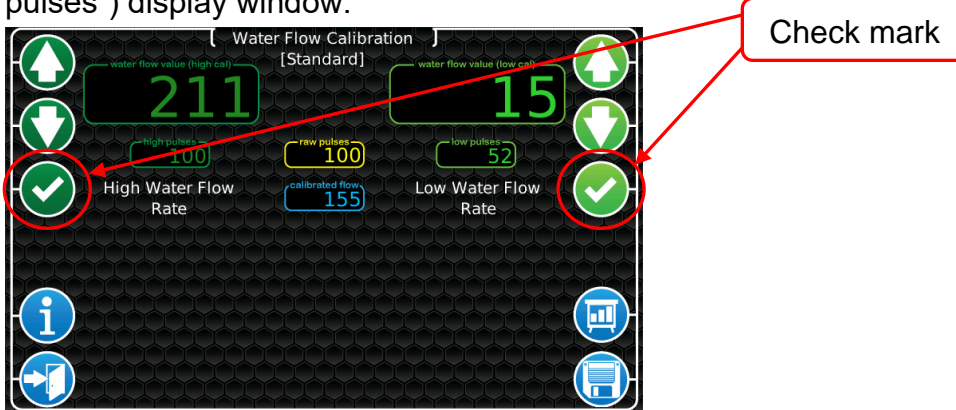

6. Perform these same steps for the other flow rate.
7. Press the “save” button to complete the calibration. Decrease the throttle and stop water flow.

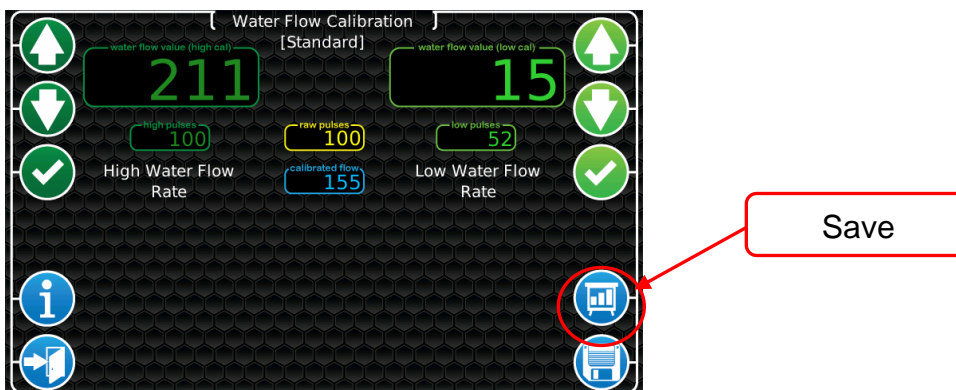

8. Press the “exit” button to return to the calibration menu.

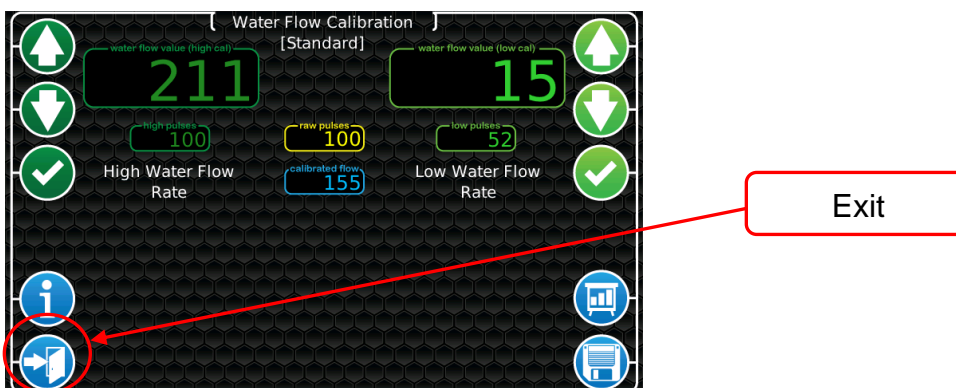

## WATER FLOW CALIBRATION (DIRECT)

The direct water flow calibration is simply a means of entering the values from a previous water flow calibration without the need to actually flow water. The direct water flow calibration requires the known values for the water flow value and its related water flow pulses (high and low) from a previously completed calibration. This is typically used when having to replace the SmartCAFS Controller or when another vehicle is determined to be exactly the same as a previous vehicle.

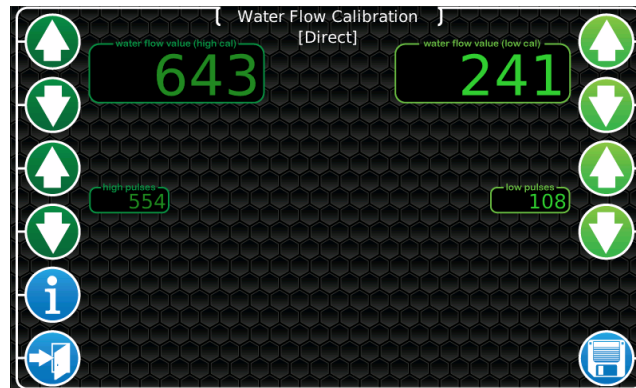

## FOAM FLOW CALIBRATION

The foam flow calibration requires the discharge of a known quantity of foam concentrate into a calibrated container.

**NOTE:** Be sure to set the foam bypass handle into the “bypass” position so that the discharged foam concentrate may be collected.

1. Place the foam bypass handle into the “bypass” position.
2. Place the calibrated container so that it will be filled with foam concentrate as it is discharged through the bypass hose.
3. Press the power button.

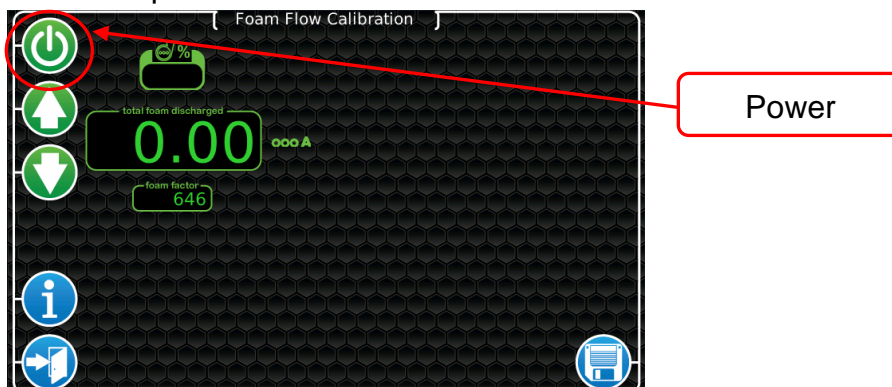

4. The bar graph will increase to indicate that the foam pump is running and the system will begin discharging foam concentrate. The “total foam discharged” display will begin incrementing.

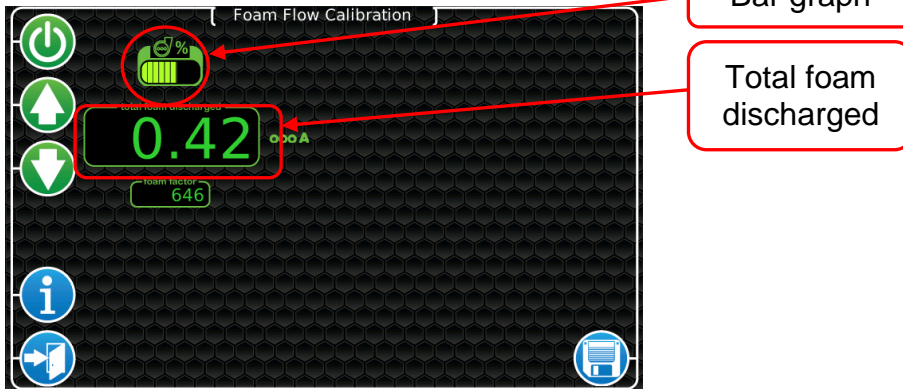

5. When the foam concentrate has filled the container to a known level press the power button again to stop the foam system.

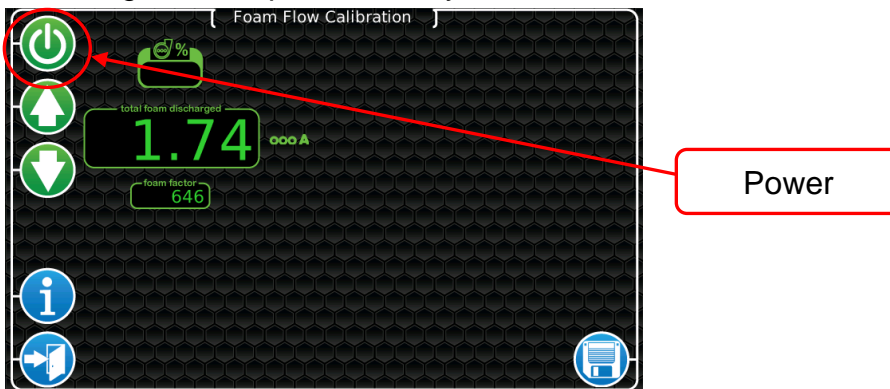

6. Use the UP/DOWN arrow buttons to change the value shown in the “total foam discharged” window to reflect the value actually collected in the container (the “foam factor” value will be changing, but in the inverse direction).

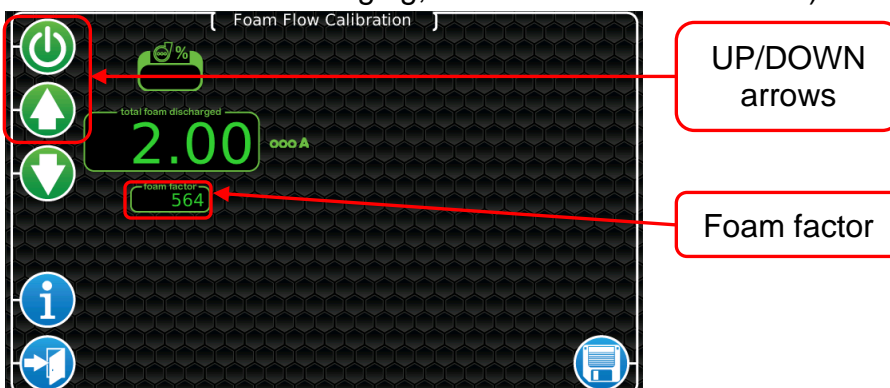



7. Press the “save” button. Press the “exit” button to return to the calibration menu.

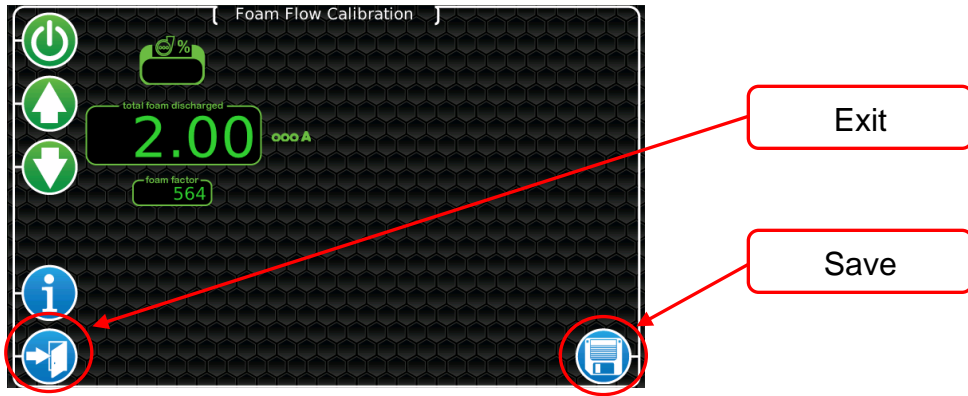

8. Place the bypass handle back to the “inject” position.

# CONFIGURATION

## PRESET CONFIGURATION (STANDARD)

The SmartCAFS Controller allows up to 10 presets to be configured. These presets can be set for foam only or foam and air (CAFS).

Enter the password **1023** in the system menu's keyboard to open the preset configuration menu.

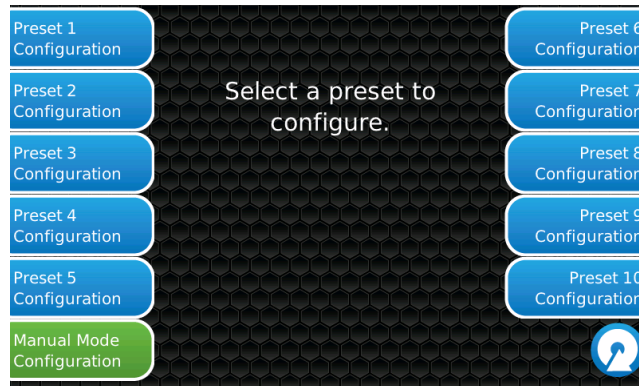

Select the preset to configure and that preset's configuration screen will be shown.

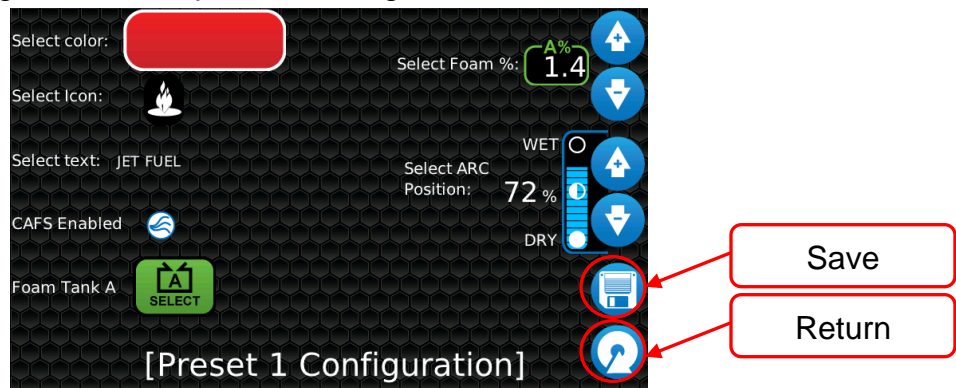

- Select color: - select the color for the preset's bar (green, red, orange, purple, blue, disabled). If "disabled" is selected then the preset is turned OFF.
- Select icon: - select the icon to use for this preset.
- Select text: - pops-up a keyboard so that text can be set for this preset (9 characters per line, up to 3 lines).
- CAFS enabled/disabled - select whether this preset will be using CAFS or foam only.
- Foam Tank: - select which foam tank is used with this preset. If the foam selector is not set for the correct tank the SmartCAFS Controller will pop-up a warning to inform the operator to switch to the correct tank.
- Select foam %: - set the foam concentrate percentage required for this preset (this option is only visible if CAFS is enabled for this preset).
- Select ARC position: - set the consistency of the CAFS by setting the Air Ratio Control valve between WET and DRY (this option is only visible if CAFS is enabled for this preset).
- "Save" button - save this preset to memory.
- "Return" button - return to the "select a preset" configuration menu.

## PRESET CONFIGURATION (LIVE)

Once a preset has been configured via the standard configuration it may not have produced the CAFS consistency desired. The “live” preset configuration allows the operator to flow CAFS while adjusting the consistency and then re-save that new value to the desired preset.

Enter the password **40692** in the system menu’s keyboard to open the user menu. This enables the “live” preset ability. Information banners will pop-up to indicate that the “live” preset ability has been activated. Touch the banner to dismiss the message.

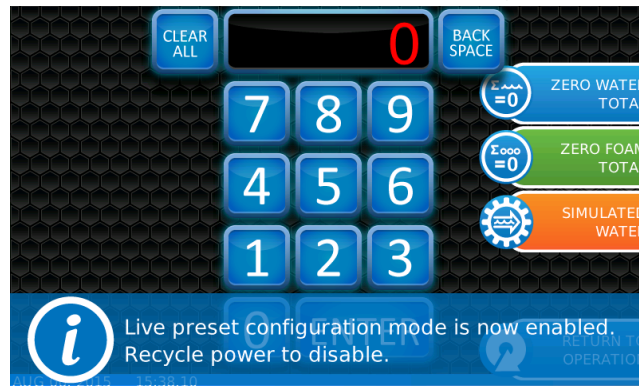

**NOTE:** You must recycle the SmartCAFS Controller’s power to disable the live preset configuration.

1. Select the desired preset from the preset page. You will notice a “save” icon above the currently selected preset (bottom left corner of the screen).

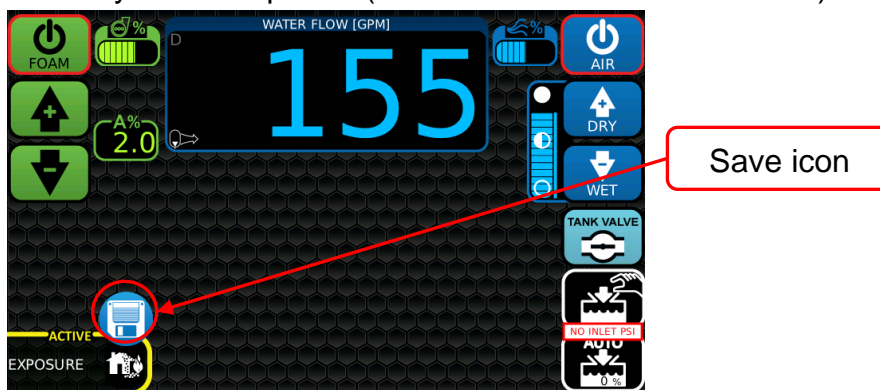

2. Run the CAFS and adjust the CAFS consistency as desired (WET/DRY buttons).
3. Press the button next to the currently selected preset indicator. The “saving” indicator will appear momentarily indicating that the new consistency has been saved.

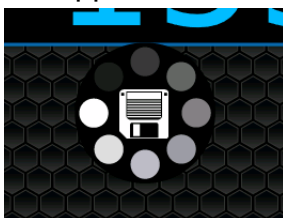

## ON-SCREEN WARNINGS AND INFORMATION

The SmartCAFS Controller uses on-screen pop-up warnings and information to indicate system status to the operator.

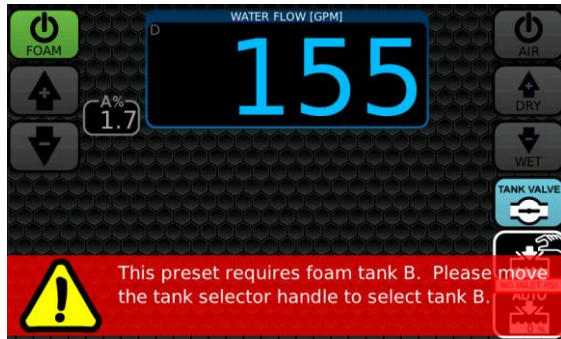

Figure 36: Warnings use a red background



Figure 37: Information uses a blue background

Touch the warning/information to dismiss it (inhibited). The warning will be hidden for the number of seconds set in the OEM menu’s “warning inhibit timeout.” If the condition that caused the warning still exists, then the warning will pop-up again.

## MAINTENANCE MINDER

This reminder in Figure 38 is only displayed at initial power up and won't return until the next power cycle if maintenance is still due. Touch anywhere on the screen or any button to clear the reminder.

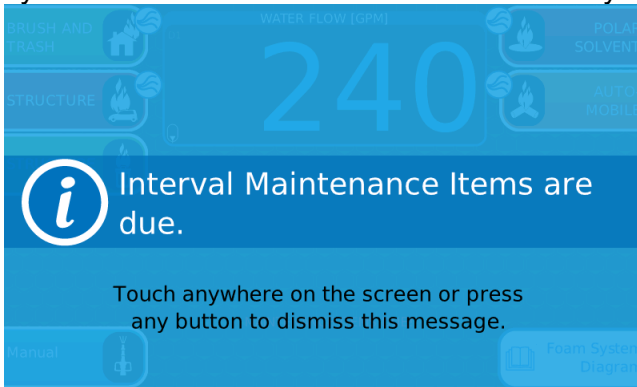

Figure 38: Maintenance Reminder Warning Message

Figure 39 shows the “maintenance minder” bar when maintenance items are due (the background of the bar turns from blue to red). When no items are past due the button will be blue.

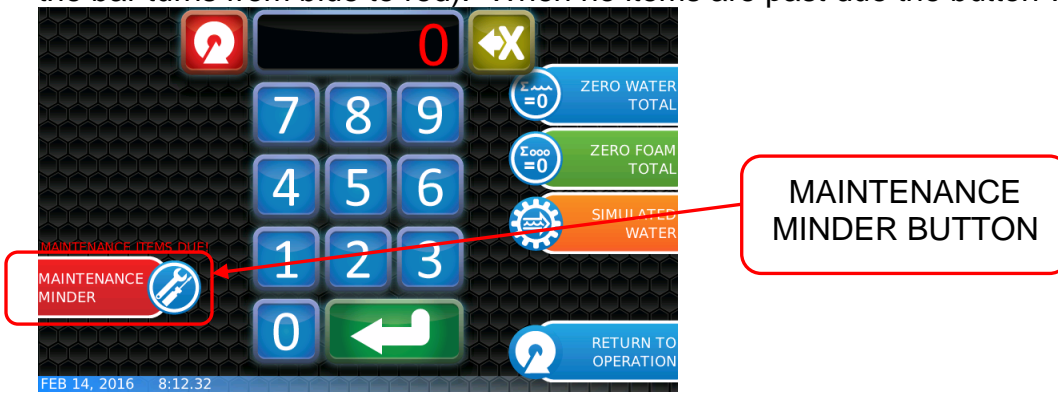

Figure 39: Maintenance Minder has changed to Red from Blue

The maintenance minder page shows the maintenance intervals and when they will be due. The pie chart provides a visual indication of how much time until the maintenance is required.



Figure 40: Maintenance Minder Page

When maintenance is due it will be indicated by a fully red pie chart and the text "DUE". Press the "i" button next to any maintenance interval to see what maintenance is required.

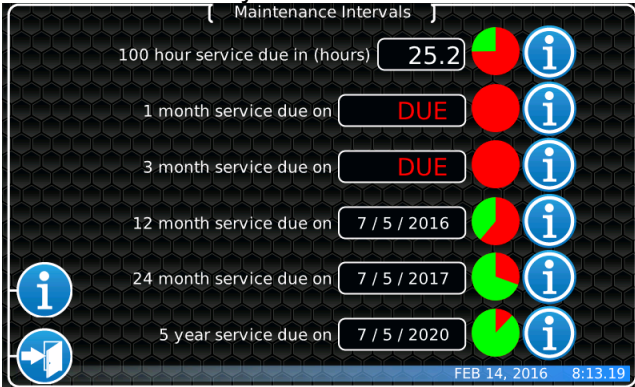

Figure 41: Maintenance Minder with past due items

The tutorial button ("i" on the left side) will explain the windows, pie charts, information button, and how to reset the maintenance schedule (requires password).

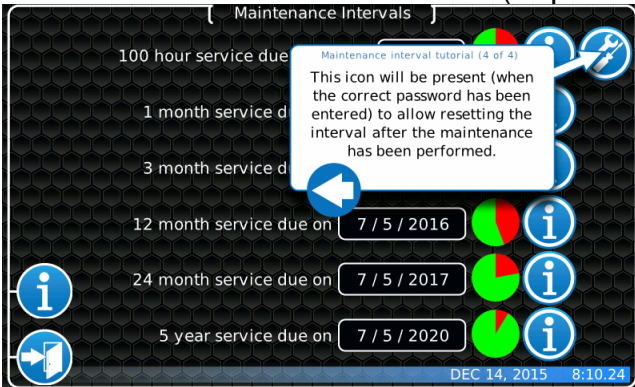

Figure 42: Maintenance Minder Tutorial

When the maintenance password has been entered the maintenance screen will have the maintenance reset button next to each interval item.



Figure 43: Reset Screen for Maintenance Minder

## ROUTINE MAINTENANCE

Between operations of the SmartCAFS unit make sure system components are filled with the proper grade and amount of oil. These components include the Air Compressor System and the Drive Unit Gearbox.

The following procedures are provided to assist in the periodic maintenance of oil levels. For detailed maintenance instructions of individual components, refer to the maintenance and operation manuals that were supplied with the apparatus.

Service should be performed by a trained and qualified service technician, or your authorized Hale Products service representative. Be sure you have sufficient knowledge, experience, proper tools and Hale genuine replacement parts before you attempt any repair maintenance.

For an illustrated SmartCAFS system, see: "MAJOR COMPONENTS AND CONTROLS" on page [14](#).



**DO NOT PERFORM MAINTENANCE ON THE SmartCAFS SYSTEM WHILE THE APPARATUS IS RUNNING. MAKE SURE THE APPARATUS IS SHUT DOWN AND COMPONENTS HAVE COOLED BEFORE ATTEMPTING MAINTENANCE.**

**THE PROPER OIL LEVEL MUST BE MAINTAINED IN THE AIR COMPRESSOR SYSTEM AT ALL TIMES. LOW OIL LEVEL OR NO OIL COULD RESULT IN EXCESSIVE COMPRESSOR TEMPERATURE AND MAJOR DAMAGE. HIGH OIL LEVEL COULD CAUSE THE CONTROL SYSTEM TO MALFUNCTION OR CAUSE A DRIVE FAILURE.**

## AIR COMPRESSOR MOISTURE DRAIN

After the air compressor system is used and has had time to COOL to ambient temperature, accumulated moisture must be drained from the oil reservoir separator.

### Drain Moisture

To drain the moisture from the system, locate the oil and moisture drain valve on the bottom of the oil reservoir separator. See: "MAJOR COMPONENTS AND CONTROLS" on page [14](#).

1. Place a suitable container 8 to 10 ounces (237 to 296 ml) under the compressor drain valve and remove the brass valve plug.
2. Open the valve and allow the water to drain. The oil drain valve is a 1/4" NPT ball valve.
3. Monitor the flow. As soon as pure oil begins flowing, CLOSE the valve.
4. Replace the brass valve plug in the valve and check the oil level.



**DISPOSE OF THE WASTE WATER/OIL IN ACCORDANCE WITH YOUR LOCAL RECYCLING REGULATIONS.**

**Note:** In humid weather, after short run times, up to 8 ounces (237 ml) of condensation could accumulate. Running the compressor for longer periods automatically removes moisture through the discharge with the air and heating of the oil.



## OIL AND OIL FILTER

**NOTE:** The air compressor oil and oil filter must be changed every **100** hours of operation or when the apparatus engine oil is changed.

### To Change Oil and Oil Filter

**NOTE:** Reference pages [14](#) & [34](#) for drain & component locations.

1. Locate the oil reservoir separator and air compressor oil filter on the apparatus
2. Place a waste container below the drain valve to catch the oil or moisture as it drains. The container must have sufficient capacity to hold the drained oil, approximately 8 to 9 quarts (7.5 to 8.5 litres).
3. Remove the valve plug and OPEN the valve to drain all oil.
4. When all oil has drained from the system, CLOSE the valve and REPLACE the valve plug.
5. Place the waste container under the oil filter and unscrew the filter from its mount adapter. An oil filter strap-wrench might be necessary to loosen the filter.
6. Drain remaining oil from the filter.



**DISPOSE OF THE WASTE WATER / OIL AND OIL FILTER IN ACCORDANCE WITH YOUR LOCAL RECYCLING REGULATIONS.**

7. Obtain a “new” Fram HP6A oil filter (Hale p/n: 010-0650-01-0). (Currently a substitute does not exist.) Before installing the new filter, lightly coat the filter gasket with SAE 15W-40HD oil, and then fill the filter approximately 1/2 full with SAE 15W-40HD oil.

**NOTE:** The oil filter must have a 200 PSI (14 BAR) pressure rating, as well as a screen over the bypass valve. The bypass screen catches large particles when oil bypasses the filter.



**USE THE EXACT REPLACEMENT OIL FILTER (Fram HP6A, Hale p/n: 010-0650-01-0). OTHER FILTER TYPES MAY NOT WITHSTAND THE SYSTEM PRESSURE AND OIL FILTER FAILURE COULD LEAD TO A MAJOR COMPRESSOR FAILURE.**

8. Screw the new oil filter onto the oil filter adapter being careful not to cross thread the filter. Initially tighten the filter hand-tight, and then tighten an additional 1/2 to 3/4 turn using an oil filter wrench.
9. Remove the oil fill plug from the fill pipe located on the oil reservoir separator. See sheet [36](#)
10. Refill system with oil. The system requires approximately 8 to 9 quarts (7.5 to 8.5 liters) of SAE 15W-40HD motor oil. The proper oil level is when oil is visible in 1/2 to 3/4 of the sight gauge when the compressor is NOT running.

 **WARNING** 

ALWAYS ALLOW OIL TO SETTLE PRIOR TO CHECKING LEVEL. DO NOT OVERFILL THE SYSTEM.

THE PROPER OIL LEVEL MUST BE MAINTAINED IN THE AIR COMPRESSOR SYSTEM AT ALL TIMES. LOW OIL LEVEL OR NO OIL COULD RESULT IN EXCESSIVE COMPRESSOR TEMPERATURE AND MAJOR DAMAGE. HIGH OIL LEVEL COULD CAUSE THE CONTROL SYSTEM TO MALFUNCTION OR A DRIVE FAILURE.

11. When the system is filled to the proper level, check and clean the O-ring seal on the fill plug, then replace the plug. DO NOT over-tighten.

12. Start the system and energize the air compressor to allow pressure to build and circulate oil through the hoses.

 **WARNING** 

WHEN STARTING DSD SmartCAFS UNIT DURING MAINTENANCE, MAKE SURE ALL TOOLS AND LOOSE CLOTHING ARE KEPT AWAY FROM ROTATING COMPONENTS. KEEP HANDS, FACE AND ARMS AWAY FROM ROTATING COMPONENTS WHILE SYSTEM IS OPERATING.

13. DO NOT allow the system to operate for more than 30 seconds. While the system is running check for leaks at the oil filter, drain plug and fill plug.

14. Shut down the system and allow the air compressor oil to settle.

15. Check oil level and add oil as necessary until oil is visible in 1/2 to 3/4 range of the sight gauge tube.

16. Shut down the system.

### COOLING WATER STRAINER

The stainless steel mesh strainers prevent any solids or debris in the pump water from passing into the heat exchanger where they can clog and lead to overheating and serious damage. They can be easily cleaned using warm water, and/or then replaced.

 **WARNING** 

**DO NOT REMOVE STRAINER CAP WHILE PUMP IS RUNNING.**

The strainer should be cleaned and checked after each use or every month. The 1-1/2" NST Cap is located on the passenger side of the apparatus.

- The stainless steel mesh basket pulls out for cleaning.
- Clean thoroughly using warm water. Replace if the screen is ripped or damaged. Order Hale p/n: 010-0670-00-0.

### AIR CLEANER ELEMENT

Change the air cleaner element on the SmartCAFS System every time the engine air filter is changed. Order Hale p/n: 010-0690-00-0.

## COMPRESSOR BELT MAINTENANCE

### REMOVE BELT GUARD

To expose the belt, the belt guard, 6 screws, and hardware must be removed.

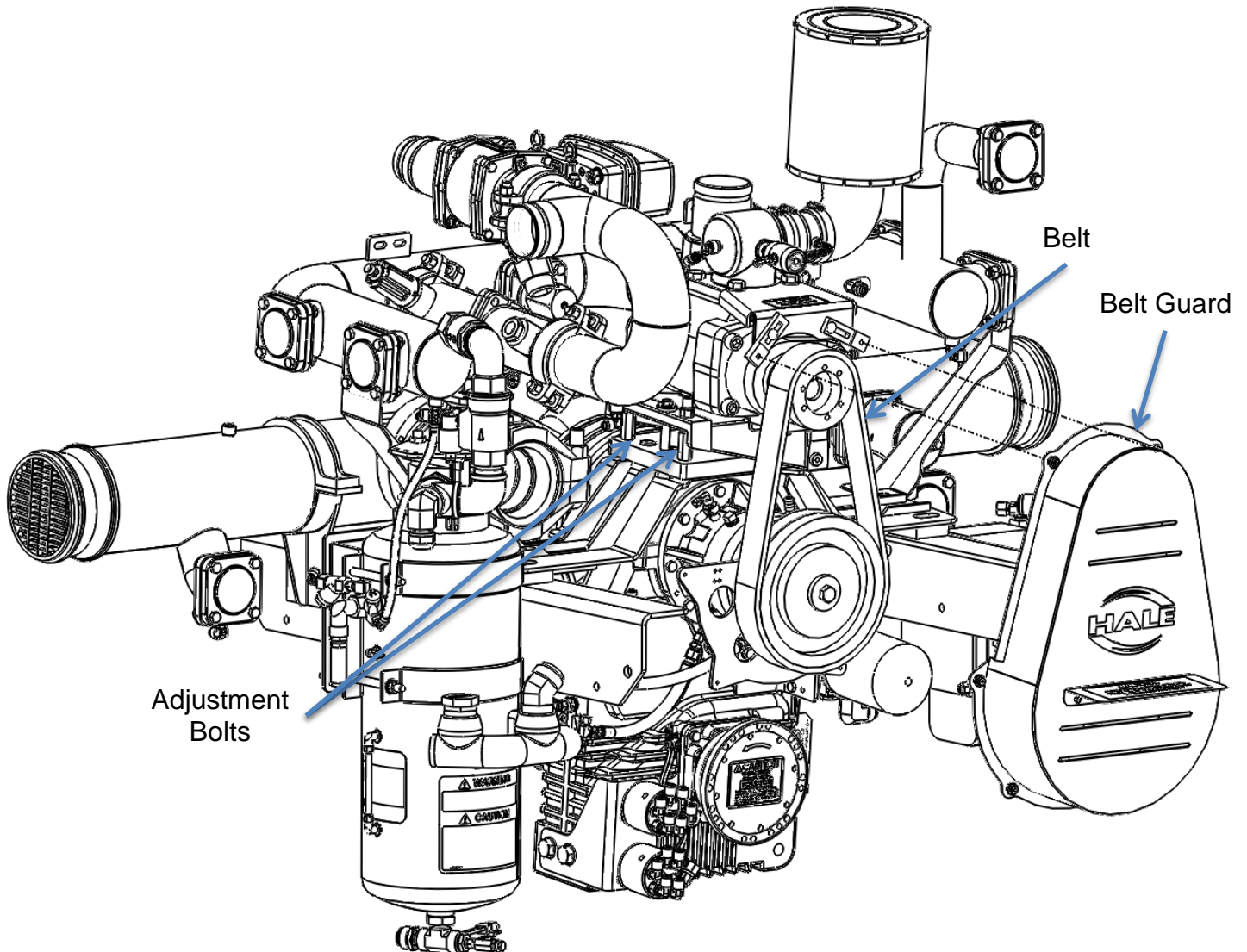

Figure 44: Belt Guard Location (DSD Shown)



Proper belt tension is critical to long equipment life. A loose belt causes a knock or bang as the teeth jump. An over tightened belt overloads the bearings and leads to premature wear or failure.

## CHECKING BELT TENSION

1. Use a belt tension gauge to determine the tension applied to the belt and check on the left side of the unit (See Figure 45).
2. From the front tip of the gauge, measure back  $5/16$ " (8 mm) and position the large O-ring accordingly. (See Figure 46)
3. Slide the smaller O-ring as close as possible to the body of the gauge setting "0."
4. Make sure that the body of the strain gauge is perpendicular to the belt when applying force. (See Figure 45) Push gauge towards the belt until the body of the gauge moves  $5/16$ " (8 mm) along the scale (or ruler) to the large O-ring setting. (See Figure 45)
5. Remove the gauge and read the tension established by the smaller O-ring. (See Figure 46) If tension is lower than 16 lbs. (7 kg.), the belt is loose; if the tension is greater than 20 lbs. (9kg.), the belt is too tight. To adjust, see heading "Adjusting Belt Tension."

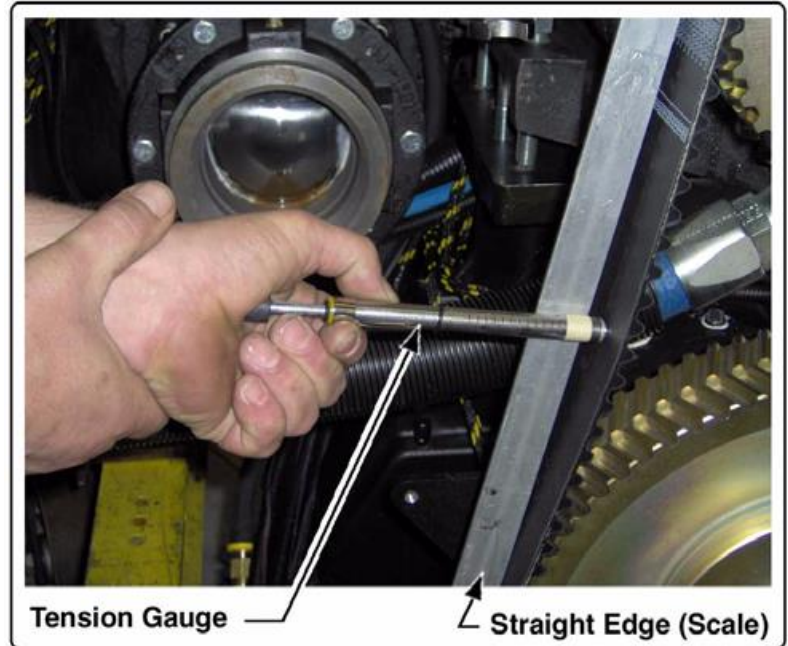

Figure 45: Measuring Tension using a Scale

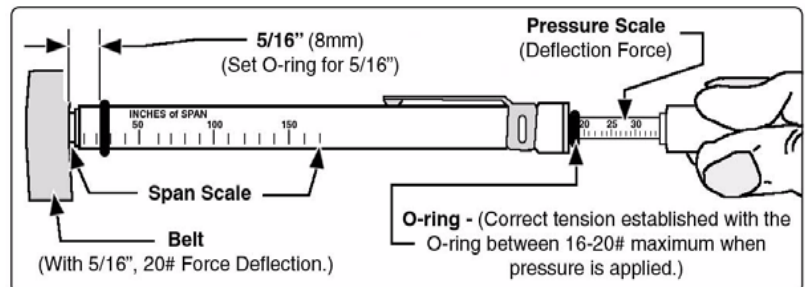

Figure 46: Belt Tension Gauge

**NOTE:** The tension gauge shown is a Goodyear® Industries, Tension Tester. (Order from Hale Products, p/n: 029-0680-00-0.)

## ADJUSTING BELT TENSION

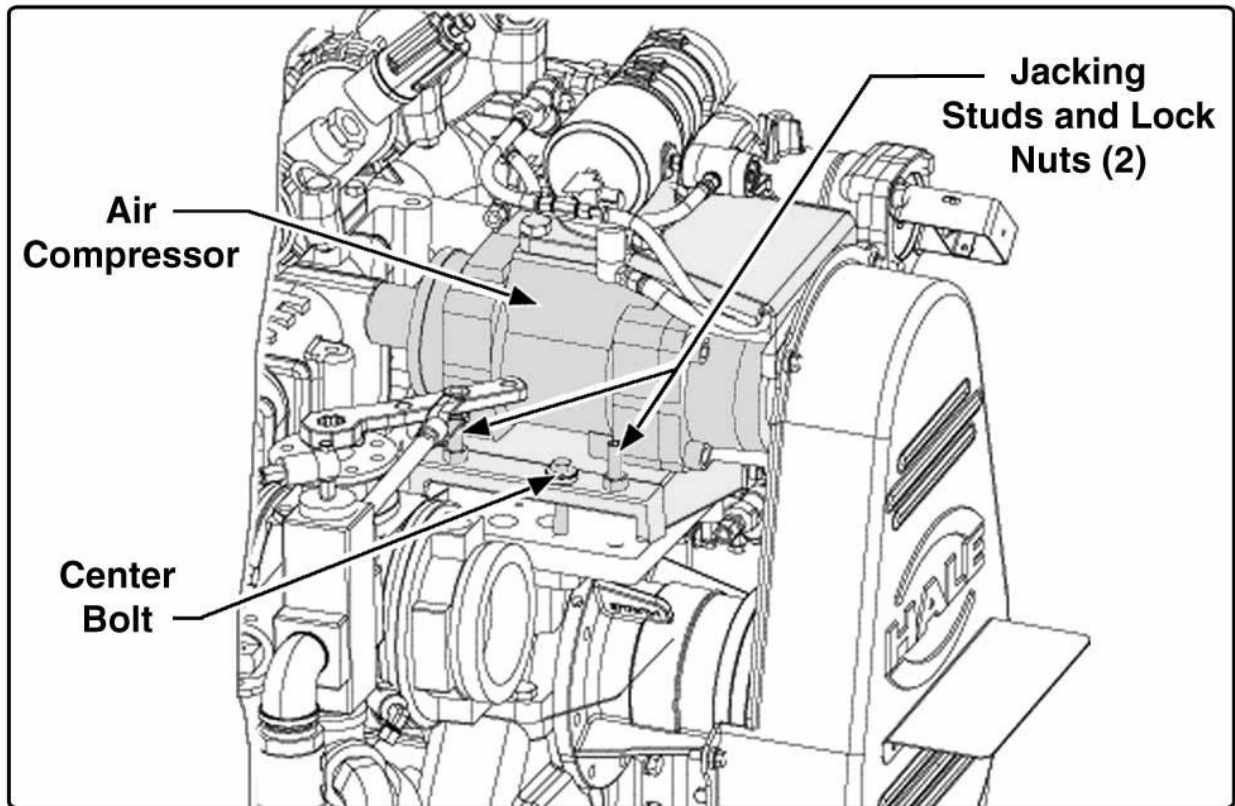

Figure 47: Belt Tension Adjustment Bolts

1. If the belt tension is less than required:
  - a. Loosen the center bolt located in the middle of the compressor mounting bracket. (See Figure 47)
  - b. Tighten two jacking studs located at both ends of the mounting bracket.
  
2. If the belt tension is tighter than required:
  - a. Loosen the two studs located at both ends of the mounting bracket. (See Figure 47)
  - b. Tighten bolt located in the middle of the compressor mounting bracket. Also tighten the two lock nuts against the bracket.
  
3. Verify that the belt tension is within the required limits. Readjust accordingly.

## HOT SHIFT CLUTCH MAINTENANCE

**NOTE:** The hot shift clutch oil should be changed every 100 hours of operation or when the apparatus engine oil is changed. (See Figure 48)

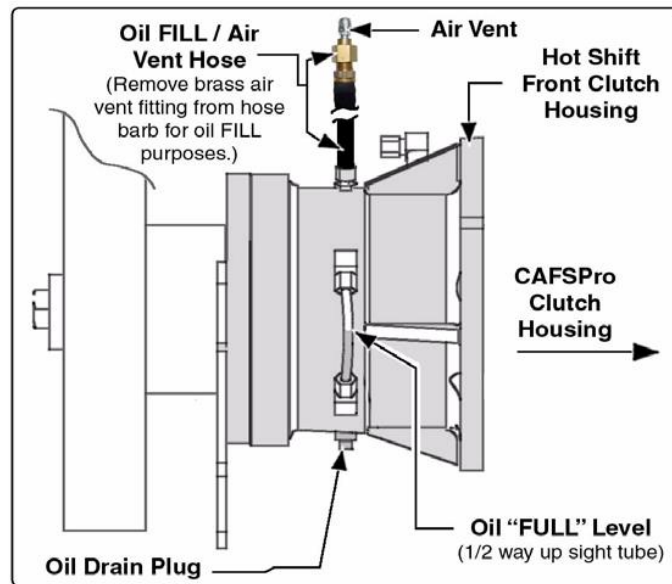

Figure 48: Hot Shift Operation

### CHANGING CLUTCH OIL

1. Place a suitable container 12 to 14 ounces under the hot shift front clutch housing and remove the brass drain plug.
2. Drain all oil then reinstall the brass drain plug.
3. Remove the brass fitting, containing the air vent, from the fill tube hose barb. (See Figure 48)



**ATTENTION**

**DISPOSE OF THE WASTE WATER/OIL IN ACCORDANCE WITH YOUR LOCAL RECYCLING REGULATIONS.**

4. Using a squeeze bottle or funnel, refill the housing via the hose barbed fitting and fill hose with Dexron III or Mercon ATF or equal, **while watching the oil level sight gauge**. The housing holds approximately twelve (12) ounces (0.4 liters). The proper oil level is when the oil level sight tube is filled half way between the top and bottom.



**WARNING**

**ALWAYS ALLOW OIL TO SETTLE PRIOR TO CHECKING LEVEL. DO NOT OVERFILL THE SYSTEM.**

**THE PROPER OIL LEVEL MUST BE MAINTAINED IN AT ALL TIMES. LOW OIL LEVEL OR NO OIL COULD RESULT IN EXCESSIVE OPERATING TEMPERATURES CAUSING MAJOR DAMAGE. HIGH OIL LEVEL COULD CAUSE THE SYSTEM TO MALFUNCTION OR COULD CAUSE A DRIVE FAILURE.**

## MAINTENANCE SCHEDULE FOR SMARTCAFS

**NOTE:** The HALE service intervals replace those in the Gardner Denver Compressor manuals.

EQUIPMENT	ACTION	Click below for Procedure W/ Internet Hyperlinks or Internal Page Links
<b>EVERY 3 MONTHS</b>		
<b>DSD</b>	Check the pump and gearbox oil levels	Page <a href="#">34</a>
	Do a vacuum test to test for leaks	Page <a href="#">89</a>
<b>Compressor</b>	Check the oil level and top up if necessary. Run compressor for 15 minutes	Page <a href="#">35</a>
	Check the drive belt tension and condition.	Page <a href="#">83</a>
<b>Mixing Manifold</b>	Grease air ratio control ball valve	Page <a href="#">88</a>
<b>Foam unit 3.3/5.0/6.5</b>	Check that foam pipe connections are tight	<a href="#">Foam unit Manual FSG-MNL-00158</a>
	Operate the system in bypass to move the concentrate and prevent gelling (if concentrate is left in the system <b>without use</b> for three months)	
<b>EVERY 12 MONTHS</b>		
<b>Compressor</b>	Change the air filter	Page <a href="#">82</a>
	Change the oil and oil filter	Page <a href="#">81</a>
<b>Hot Shift Clutch</b>	Change the oil	Page <a href="#">86</a>
<b>Gearbox</b>	Change the gearbox oil	<a href="#">DSD Maintenance Manual 029-0020-93-0</a>
<b>Pump</b>	Inspect the anode, replace if needed	<a href="#">DSD Maintenance Manual 029-0020-93-0</a>
<b>Priming pump</b>	Clean & lubricate	<a href="#">HSB64</a>
<b>Suction Manifold</b>	Inspect the anodes, replace if needed	Page <a href="#">99</a>
<b>Foam unit 3.3/5.0/6.5</b>	Inspect wiring/connections, hoses/connections	<a href="#">Foam unit Manual FSG-MNL-00158</a>
	Clean the foam strainer	
	Verify water flow calibration	
	Verify foam feedback calibration	
<b>EVERY 24 MONTHS</b>		
<b>Compressor</b>	Replace the oil separator element	<a href="#">CAFS Maintenance &amp; Repair Manual 101-2850-00-0</a>
<b>EVERY 5 YEARS</b>		
<b>Compressor</b>	Replace the compressor drive belt	Page <a href="#">83</a>



In high usage or abnormal operating conditions, the above procedures may need to be more frequent. The best practise is to flush the system after each use. Intervals are automatically tracked in the UV Display under the maintenance tab.

## MAINTENANCE OPERATIONS PUMP – SMARTCAFS

### CAFS MIXING MANIFOLD – GREASING BALL VALVE

The CAFS Mixing Manifold contains a ball valve as part of the air ratio control system. This ball valve must be maintained by inserting lubricating grease at three monthly intervals to ensure smooth and efficient operation.

#### LUBRICANTS:

Use one of the following lubricants. DO NOT substitute other lubricants.

- **Never-Seez** - White Food Grade with PTFE, manufactured by:

Bostik Findley, Inc.  
 211 Boston Street  
 Middleton, MA. 01949-2128  
 Web: <http://www.bostik-us.com>

- **White Knight** <sup>tm</sup> - Food Grade Anti-Seize Compound, manufactured by:

Jet Lube Inc.  
 4849 Homestead Road  
 Suite 500  
 Houston, TX 77028  
 Web: [www.jetlube.com](http://www.jetlube.com)

- **Anti-Seize** <sup>tm</sup> - manufactured by:

U.S. Valve Service & Training, Inc.  
 11875 West Little York  
 Suite 502  
 Houston, TX. 77041  
 Web: [WWW.USVALVESERVICES.COM](http://WWW.USVALVESERVICES.COM)

Also see SVS Torrent Installation and Service Maintenance Manual, Hale p/n: [029-0020-90-0](#), Section 4 “Routine Maintenance” for additional information.

The grease is inserted through one or two grease nipples. The first nipple is located on the side of the valve facing the discharge end of the manifold. If a second nipple is fitted, it will be on the other side of the manifold. Connect a suitable grease gun to the nipple and insert grease until a resistance is felt, this indicates that sufficient grease has been inserted.

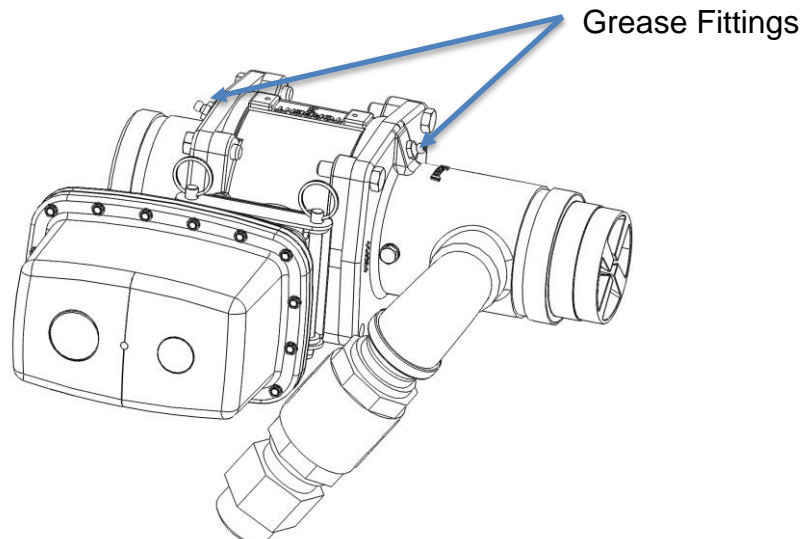

Figure 49: ARC VALVE



## VACUUM TEST PUMP MANIFOLD

If the pump will not hold the vacuum with the blanking caps in position, a leak is present in the pump, and the pressure test detailed below must be carried out to trace it.

Should the pump not reach a vacuum of 20inHg [0.7bar] but will hold a lower pressure, a fault in the priming system is indicated.

If the pump will not achieve 22inHg [0.74bar] vacuum for NFPA, and will not hold what it does achieve, there is a leak, and possibly also a fault, in the priming system.

### Check as follows:

Check the priming pump performance and related hose connections between the priming pump and primer valve. Debug the priming system as described in [HALE Service Bulletin 64](#). If the vanes are determined to be worn (sometimes indicated by smoke exhausting from the water exhaust port during operation), a rebuild kit is available as noted within the recommended spares kit section in this manual.

## PRESSURE TEST – PERFORMED WITHOUT PUMP RUNNING

This test is to be carried out if the pump will not hold a vacuum with blanking cap(s) in position, and is intended to trace the leaks responsible for the loss of vacuum.

Apply a water pressure of 50 – 100 PSI [3.5 - 7.0 bar] to the DSD pump and check for leaks. The area causing the leak should be visible, and can be dismantled and rectified. If no leaks are apparent, the leakage must lie between the priming valve and the primer pump.

## CAFS - SETTING THE AIR BALANCE CONTROL VALVES

1. Symptoms of Improper Adjustment
  - a. Air pressure fluctuates or bounces too far from water pressure on the duplex gauge:
    - i. The snubber valve is open too much
  - b. A “popping” sound is observed within the air intake filter & ducting:
    - i. The snubber valve is closed too much.
2. Functionally Test Smart CAFS Air Pressure /Water Pressure & Adjust Match
  - a. The water pump should be running at 700-800 RPM and discharging water.
  - b. Turn system ON by pressing . LED bar graph on display should light up and foam should start pumping.

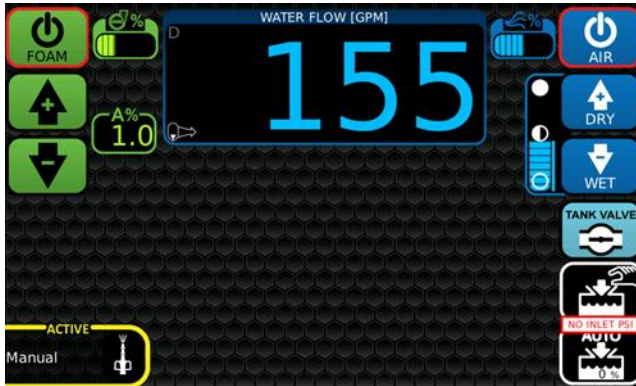

- c. Close the discharge valve completely on the CAFS manifold.
- d. While observing the duplex gauge, engage compressor clutch with the **BLUE AIR** power button  and increase engine speed and pump pressure to 75 PSI. Air pressure should follow & match while maintaining a stable reading.
- e. Adjust the flow valve located on the side of the air intake to increase or decrease the air flow/pressure for the compressor. Adjust the snubber valve on intake valve body (located on the top of the air compressor) to dampen out pulses and fluctuations to achieve smooth operation as indicated on the duplex gauge.
- f. Lock in place with lock nut. Repeat for “g” through “i” to fine tune compressor air pressure/water pressure match.

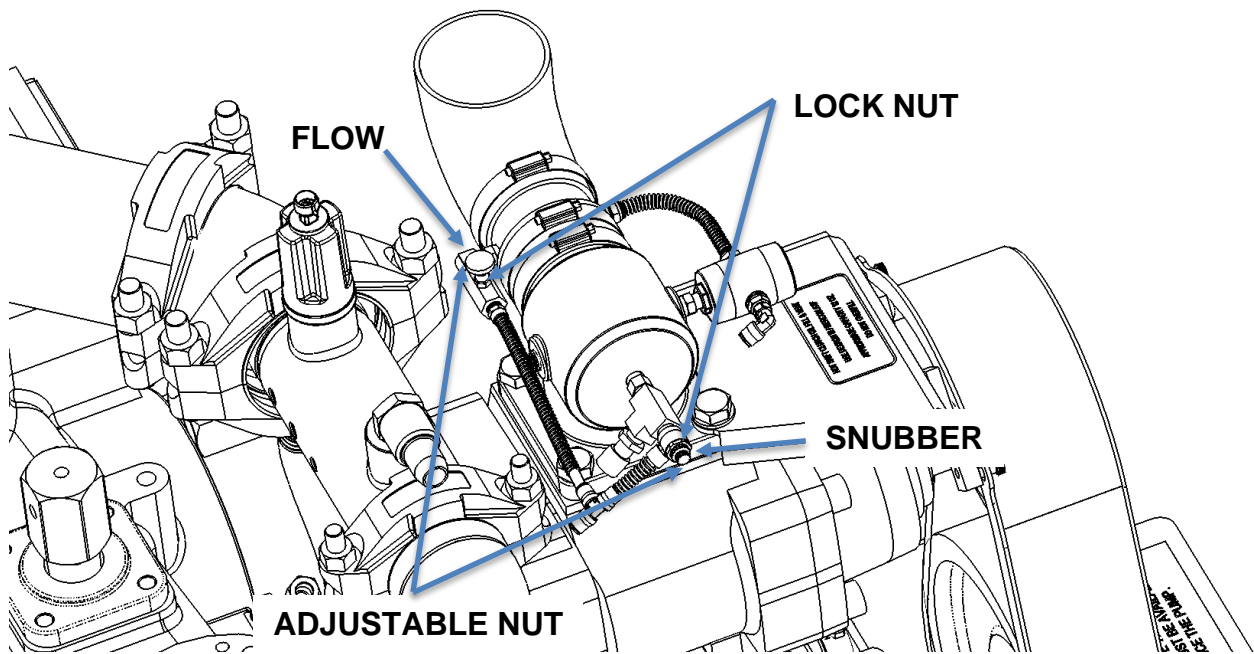

Figure 50: Compressor Intake Adjustment

- g. Increase engine speed to 100 psi. Air pressure should follow.
  - h. Increase engine speed to 125 psi. Air pressure should follow.
  - i. Increase engine speed to 150 psi. Air pressure should follow.
  - j. Slowly reduce engine speed to 900 RPM. (Compressor will make howling noise that is much louder if speed is reduced quickly).
3. If the system is still not tracking then there might be an issue with the air balance valve.
- a. If you can't get the system to go wet, but can get it to go dry or there is a large delay in air pressure when increasing/decreasing water pressure. Grease the O-ring indicated in Figure 51.
  - b. If you can't get the pressure to match in either wet or dry operation the air balance valve may be damaged. Remove the air balance valve and measure the ID of the water pressure inlet, if it is less than 5.97 mm it may be damaged.

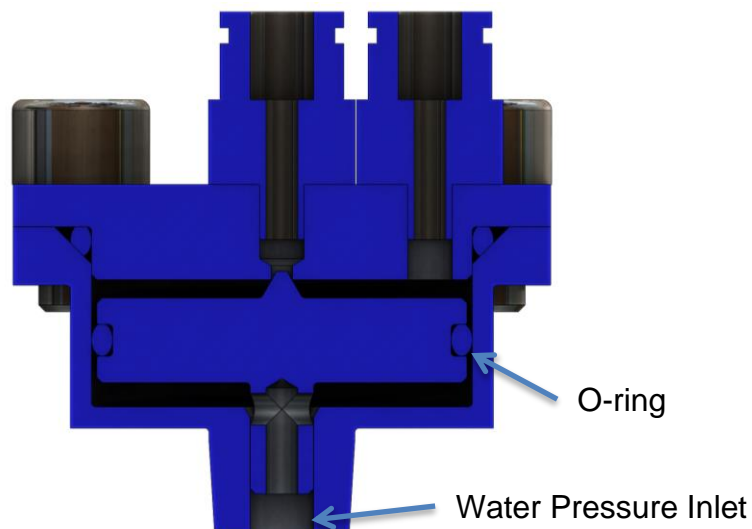

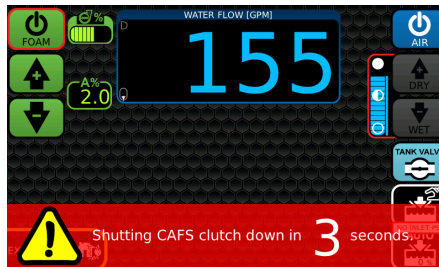

Figure 51: Air Balance Valve (61215) Cross Section

## CAFS – HOT SHIFT CLUTCH ENGAGEMENT

1. The hot shift clutch is engaged when the CAFS switch is activated.
  - a. Pressing the CAFS enable switch to engage the hot shift clutch. “

- b. Pressing the  on the screen or button for 3 seconds will disengage the hot shift clutch.



2. When the CAFS switch is activated, the clutch solenoid valve is then energized allowing pressurised air to engage the clutch.
3. Setting the hot shift clutch engagement:
  - a. The solenoid valve controls how fast or slow the hot shift clutch engages.
  - b. There is a flow control valve located on the air output side of the solenoid valve. Adjusting this flow control causes the hot shift clutch to engage faster or slower.
    - i. Adjusting (closing) the flow control to engage the clutch too slowly will reduce the life of the clutch itself.
    - ii. Adjusting (opening) the flow control to engage the too quickly will cause the pump to “shutter” & possibly cause the drive belt to jump a tooth.
  - c. The standard HALE set point for the flow control is the following:
    - i. Loosen the set screw on the side of the adjustment knob.
    - ii. Rotate the adjustment knob inward to the closed position.
    - iii. Rotate the adjustment knob outward 2-1/4 turns (until you see the beginning of the blue ring)
    - iv. Lock the adjustment knob’s position by tightening the set screw on the side of the adjustment knob.
  - d. Fine tuning beyond the standard set point may be necessary. This is completed by engaging the clutch & observing the performance of the pumping system & the compressor. Adjusting the flow control in or out slightly as needed after disengaging & re-engaging the clutch for best performance. Allow the pumping system to settle 5~10 seconds between engage & disengage cycles while adjustments are made.

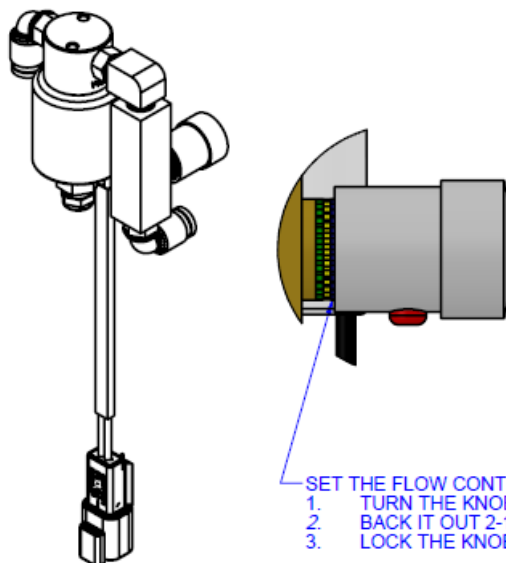

SET THE FLOW CONTROL:  
 1. TURN THE KNOB IN ALL THE WAY  
 2. BACK IT OUT 2-1/4 TURNS (UNTIL YOU SEE THE BEGINNING OF THE BLUE RING)  
 3. LOCK THE KNOB POSITION WITH THE SET SCREW

## RECOMMENDED SPARES KIT FOR SERVICE

Unit	Qty.	Item	Part Number	Comment
<b>CAFS System</b>				
	2	Filter - Oil	010-0650-01-0	
	2	Filter - Air	010-0690-00-0	
	2	Separator Element Replacement Kit	010-0950-00-0	
		Compressor Oil	SAE 15W-40HD	
		Hot Shift Oil	Dexron III or Mercon ATF	
	1	Air Inject Valve	546-00058-000	
<b>PUMP</b>				
	AR	Strainer - Hi Pressure	010-0670-00-0	
	3	Anode	029-0511-00-0	
	1	Priming Pump Repair Kit	501-3090-00-50	

**NOTE:** Under normal conditions those items marked AR (As Required) are not deemed to be disposable. However, fluid strainers may be easily damaged during the cleaning process. Please exercise care when handling. It is at the customer's discretion whether said items are carried as 'off the shelf' spares.

## HALE PUMP ILLUSTRATED PARTS LIST

Please refer to:

**DSD:** [029-0020-93-0](#)

**Q-SERIES:** [029-0020-63-0](#)

## COMPRESSOR ILLUSTRATED PARTS LIST

Please refer to:

**Gardener Denver Enduro 12 manual.**

## FOAM UNIT ILLUSTRATED PARTS LIST

Please refer to:

**Foam unit Model 3.3/5.0/6.5: FSG-MNL-00158**

# PARTS LIST

## MAJOR ASSEMBLIES

A	B	C	D	E	F	G	H	I	J	K	L	M	N																																																		
<p><b>DSD</b></p> <table border="1" style="width: 100%; border-collapse: collapse;"> <thead> <tr> <th>GEARBOX AND RATIO</th> <th>LC 2.28</th> <th>LC 2.05, 1.86, XC 2.32</th> <th>XC 2.13, 1.96</th> </tr> </thead> <tbody> <tr> <td>1:2-13 HHCS</td> <td>018-2026-02-0</td> <td>2.25" 018-2030-02-0</td> <td>3.00" 018-2032-02-0</td> </tr> <tr> <td>1:2-13 SHCS</td> <td>018-2022-08-0</td> <td>2.25" 018-2024-08-0</td> <td>2.50" 018-2026-08-0</td> </tr> <tr> <td>5:6-11 HHCS</td> <td>018-2426-02-0</td> <td>2.25" 018-2430-02-0</td> <td>3.00" 018-2432-02-0</td> </tr> <tr> <td>5:6-11 SHCS</td> <td>018-2422-08-0</td> <td>2.25" 018-2424-08-0</td> <td>2.50" 018-2426-08-0</td> </tr> <tr> <td>Ø3/8" DOWEL</td> <td>064-6900-00-0</td> <td>1.75" 064-6900-00-0</td> <td>1.75" 064-6700-00-0</td> </tr> </tbody> </table>	GEARBOX AND RATIO	LC 2.28	LC 2.05, 1.86, XC 2.32	XC 2.13, 1.96	1:2-13 HHCS	018-2026-02-0	2.25" 018-2030-02-0	3.00" 018-2032-02-0	1:2-13 SHCS	018-2022-08-0	2.25" 018-2024-08-0	2.50" 018-2026-08-0	5:6-11 HHCS	018-2426-02-0	2.25" 018-2430-02-0	3.00" 018-2432-02-0	5:6-11 SHCS	018-2422-08-0	2.25" 018-2424-08-0	2.50" 018-2426-08-0	Ø3/8" DOWEL	064-6900-00-0	1.75" 064-6900-00-0	1.75" 064-6700-00-0	<p><b>COMPRESSOR ASSEMBLY</b> (501-4140-0-0, SEE NOTE 1, ALSO, SEE PLATE FSG-PL-01306 FOR PARTS IDENTIFICATION)</p> <ol style="list-style-type: none"> <li>LOOSEN &amp; REMOVE THE COMPRESSOR BELT TENSIONING HARDWARE TO ENABLE THE COMPRESSOR TO MOVE FORWARD ALLOWING THE INSTALLATION OF THE MOUNTING HARDWARE FOR THE COMPRESSOR ONTO THE TOP OF THE GEARBOX. USE THE CHART TO THE LEFT TO DETERMINE THE PROPER MOUNTING HARDWARE.</li> <li>HARDWARE IS APPLICABLE FOR GEARBOX RATIOS SHOWN.</li> <li>REFER DOWEL PINS ARE INSERTED PRIOR TO INSTALLING COMPRESSOR ASSEMBLY ONTO THE GEARBOX AS SHOWN IN FSG-PL-01306. DO NOT TIGHTEN UNTIL DRIVE BELT IS INSTALLED.</li> </ol>	<p><b>UPPER SPROCKET</b></p> <ul style="list-style-type: none"> <li>INSTALL SPROCKET (031-1800-01-0, 28 TEETH), BUSHING OD (250-9590-00-0), KEY (017-0710-00-0) AND (3) SCREWS 5/16 X 3-3/4 LG (018-1432-25-0) ONTO COMPRESSOR SHAFT.</li> <li>TORQUE SCREWS TO 16 LB-FT.</li> </ul> <p><b>BELT INSTALLATION INSTRUCTIONS IN THE OWNER'S OPERATION MANUAL. CRITICAL REFERENCE DATA FROM WITHIN MANUAL:</b></p> <ul style="list-style-type: none"> <li>TIGHTEN BELT TO 16-20 POUNDS OF TENSION.</li> <li>DEFLECTION OF NO MORE THAN 5/16".</li> </ul>	<p><b>LOWER SPROCKET</b></p> <ul style="list-style-type: none"> <li>SEE PLATE PL10684 FOR HOT SHIFT CLUTCH-OR FOR PARTS IDENTIFICATION.</li> </ul>	<p><b>DRAIN VALVES</b> (SEE PLATE PL 1002A FOR PARTS IDENTIFICATION AND ORIENTATIONS)</p> <ul style="list-style-type: none"> <li>INSTALL DUAL DRAIN VALVE BRACKET WITH DRAIN VALVE ASSEMBLY ATTACHED TO GEARBOX USING (4) WASHERS (097-2100-00-0), ADD TWO (2) WASHERS BETWEEN THE GEARBOX AND THE BRACKET. THE BRACKET MUST BE INSTALLED UNDER THE HEAD OF THE (2) SCREWS (018-4241-00-0) 5/8 X 1-1/2 LG. DRAIN VALVES ARE OPTIONAL, CONSULT ORDER SHEET &amp; B.O.M. PRIOR TO INSTALLING.</li> <li>SEE NOTE 1</li> </ul>	<p><b>GEARBOX SUPPORT BRACKETS</b></p> <p>FRAME ARE DETERMINED BY:</p> <ul style="list-style-type: none"> <li>FRAME WIDTH</li> <li>GEARBOX RATIO</li> <li>DRIVELINE ANGLES</li> <li>CONSULT B.O.M. PRIOR TO INSTALLATION.</li> </ul>	<p><b>SEPARATOR TANK MOUNTING ASSEMBLY</b></p> <ul style="list-style-type: none"> <li>108-0630-60-0 FOR 24VDC SYSTEM</li> <li>108-0630-61-0 FOR 12VDC SYSTEM</li> <li>SEE PLATE FSG-PL-01307 FOR PARTS IDENTIFICATION AND ORIENTATIONS</li> </ul> <p>POSITION AND MOUNT SEPARATOR MOUNTING BRACKET (018-3430-00-0) AND DOUBLER PLATE (005-3700-00-0) TO THE MOUNTING BLOCK USING (4) 7/16 X 1 X 1-1/2 LG. SCREWS (018-1814-25-0) AND (4) 7/16 FLAT WASHERS (097-0250-00-0).</p> <p>APPLY 048-1700-00-0 TO INSIDE SURFACE OF (2) SEPARATOR TANK MOUNTING STRAPS (042-0550-00-0). ADD MOUNTING STRAPS TO SEPARATOR TANK MOUNTING BRACKET AND SECURE SEPARATOR TANK ASSEMBLY</p> <ul style="list-style-type: none"> <li>108-0630-60-0 FOR 24VDC SYSTEM</li> <li>108-0630-61-0 FOR 12VDC SYSTEM</li> <li>USE 093-0300-00-0 (2) 1/2" X 6" STRIPS (018-1854-02-0), (2) 7/16 FLAT WASHERS (097-0250-00-0), (2) SPRING LOCK WASHERS (097-2190-00-0), AND (2) NUTS (110-1800-02-0).</li> </ul> <p>POSITION TANK ASSEMBLY SO THAT THE SAFETY VALVE IS AGAINST TOP MOUNTING SCREW (018-1854-02-0).</p> <p>USE 1540 OIL FOR IN HOUSE TESTING.</p> <p>FILL TO THE LEVELS INDICATED ON THE LABEL LOCATED BEHIND THE OIL LEVEL SIGHT TUBE.</p> <ul style="list-style-type: none"> <li>DRAIN BEFORE SHIPPING.</li> </ul>	<p><b>PLATE HEAT EXCHANGER STANDARD MOUNTING IDENTIFICATION</b></p> <p>MOUNT PLATE HEAT EXCHANGER TO HANGER PLATE (018-5941-00-0) (ON FRAME RAIL) USING (4) 1/2" X 6" STRIPS (018-1854-02-0) AND (4) LOCK WASHERS 7/16 SPL (097-0190-00-0)</p>	<p><b>BELT GUARD</b> (044-1880-00-0)</p> <p>SEE SHEET 4 FOR DETAILS</p> <p>INSTALL (6) GROMMETS (048-1510-00-0), ATTACH THE CLUTCH SERVICE BRACKET (019-3760-00-0) AND THE CLUTCH BELT BRACKET SUPPORT PLATE (097-0250-00-0) TO BELT GUARD USING (6) LOCK WASHERS (110-1200-15-0)</p> <p>MOUNT BELT GUARD (044-1880-01-0) TO LOWER BELT GUARD SUPPORT AND ADJUSTABLE MOUNTS USING (6) SHOULDER SCREW 5/16 X 1/2 LG (018-5035-00-0) AND (6) WASHERS 5/16 (097-0810-01-0)</p> <p>(TIGHTEN CARRIAGE SCREWS ATTACHING ADJUSTABLE MOUNTS TO UPPER BELT GUARD SUPPORT)</p>		<p><b>CLUTCH AND BEAR CLUTCH HOUSING</b></p> <ul style="list-style-type: none"> <li>SEE PLATE FSG-PL-01303 &amp; PL1068 FOR PARTS IDENTIFICATION, ORIENTATIONS, &amp; INSTALLATION PROCEDURE</li> </ul>	<p><b>NOTES:</b></p> <ol style="list-style-type: none"> <li>DO NOT INSTALL TANK TO PUMP VALVE. DRAIN VALVES OR DRAINS UNLESS SPECIFIED ON B.O.M.</li> <li>APPLY LOCKWASHERS TO ALL SCREW THREADS.</li> <li>APPLY LOCITE PAST OR EQUAL TO ALL PIPE THREADS.</li> <li>SEE PLATE FSG-PL-01378 FOR HOSE CONNECTIONS SCHEMATIC</li> <li>SEE PLATE FSG-PL-01309 FOR AIR AND DRAIN PLUMBING SCHEMATIC</li> <li>SEE PLATE FSG-PL-01311 FOR ELECTRICAL SCHEMATIC</li> </ol>	<p><b>REVISIONS</b></p> <table border="1" style="width: 100%; border-collapse: collapse;"> <thead> <tr> <th>REV.</th> <th>DATE</th> <th>BY</th> <th>DATE</th> <th>APPROVED</th> </tr> </thead> <tbody> <tr> <td>01</td> <td></td> <td></td> <td></td> <td></td> </tr> <tr> <td>02</td> <td></td> <td></td> <td></td> <td></td> </tr> <tr> <td>03</td> <td></td> <td></td> <td></td> <td></td> </tr> <tr> <td>04</td> <td></td> <td></td> <td></td> <td></td> </tr> </tbody> </table>	REV.	DATE	BY	DATE	APPROVED	01					02					03					04					<p><b>PROJECTION:</b></p>	<p><b>HALE</b></p> <p><b>GODIVA</b></p> <p><b>DSD SMARTCAFS</b></p> <p><b>COMPONENT INSTALLATION</b></p> <p>SEE DRAWING NUMBER</p> <p>DATE: 01/20/2014</p> <p>REV: D</p> <p>FIG: FSG-PL-01377</p>
GEARBOX AND RATIO	LC 2.28	LC 2.05, 1.86, XC 2.32	XC 2.13, 1.96																																																												
1:2-13 HHCS	018-2026-02-0	2.25" 018-2030-02-0	3.00" 018-2032-02-0																																																												
1:2-13 SHCS	018-2022-08-0	2.25" 018-2024-08-0	2.50" 018-2026-08-0																																																												
5:6-11 HHCS	018-2426-02-0	2.25" 018-2430-02-0	3.00" 018-2432-02-0																																																												
5:6-11 SHCS	018-2422-08-0	2.25" 018-2424-08-0	2.50" 018-2426-08-0																																																												
Ø3/8" DOWEL	064-6900-00-0	1.75" 064-6900-00-0	1.75" 064-6700-00-0																																																												
REV.	DATE	BY	DATE	APPROVED																																																											
01																																																															
02																																																															
03																																																															
04																																																															

# PLATE FSG-PL-01375 HALE CAFS READY QMAX COMPONENT INSTALLATION (P/N 562-0350-45-0 - 12VDC SYSTEM)

COMP LIFT PLATE KIT	519-00013-000	519-00013-020	519-00013-030
GEARBOX AND RATIO	LC 2.28	LC 2.05, 1.88 XC 2.32	XC 2.13, 1.96
1/2-13 HHCS	018-2028-02-0   2.75"   018-2030-02-0   3.00"   018-2032-02-0   3.25"		
1/2-13 SHCS	018-2028-08-0   2.75"   018-2024-08-0   2.50"   018-2026-08-0   2.75"		
5/8-11 HHCS	018-2428-02-0   2.75"   018-2430-02-0   3.00"   018-2432-02-0   3.25"		
5/8-11 SHCS	018-2422-08-0   2.25"   018-2424-08-0   2.50"   018-2426-08-0   2.75"		
3/8" DOWEL	064-6870-00-0   1.50"   064-6860-00-0   1.75"   064-6700-00-0   2.00"		
LIFT PLATE	019-3740-00-0   1.00"   019-3740-02-0   1.00"   019-3740-03-0   1.25"		

COMPRESSOR ASSEMBLY (60-4140-30-0). SEE NOTE 1. ALSO, SEE PLATE FSG-PL-01308 FOR PARTS IDENTIFICATION.  
MOUNT COMPRESSOR LIFT PLATE AND COMPRESSOR MOUNTING BASE (019-3940-00-0) TO TOP OF GEARBOX USING APPROPRIATE CAFS COMPRESSOR LIFT PLATE KIT LISTED TO THE LEFT.  
INSTALL COMPRESSOR ASSEMBLY (60-4140-30-0) TO MOUNTING BASE USING THE SHOULDER SCREWS AS SHOWN IN FSG-PL-01308. DO NOT TIGHTEN UNTIL DRIVE BELT IS INSTALLED.

SEPARATOR TANK MOUNTING ASSEMBLY (2V (108-0630-61-0) (SEE NOTE 1. ALSO, SEE PLATE FSG-PL-01307 FOR PARTS IDENTIFICATION AND ORIENTATIONS)  
POSITION AND MOUNT SEPARATOR MOUNTING BRACKET (018-3430-00-0) AND DOUBLER PLATE (018-3700-00-0) TO THE MOUNTING BLOCK USING (4) 7/16-14 X 1-1/2 LG SCREWS (018-1814-25-0) AND (4) 7/16 FLAT WASHERS (087-0250-00-0).  
APPLY (4)S 7/8X0.9 TO INSIDE SURFACE OF (3) SEPARATOR TANK MOUNTING STRAPS (245-020-00-0). ADD MOUNTING STRAP TO SEPARATOR TANK MOUNTING BRACKET AND SECURE SEPARATOR TANK ASSEMBLY (108-0630-06-0) USING (2) 7/16-14 X 5-1/2 LG SCREWS (018-1854-02-0), (2) 7/16 FLAT WASHERS (087-0250-00-0), (2) SPRT LOCK WASHERS (087-0180-00-0), AND (2) NUTS (010-1000-02-0).  
POSITION TANK ASSEMBLY SO THAT THE SAFETY VALVE IS AGAINST TOP MOUNTING SCREW (018-1854-02-0).

PLATE HEAT EXCHANGER STANDARD MOUNTING ASSEMBLY (60-4140-30-0) (SEE NOTE 1. ALSO, SEE PLATE PL1000 FOR PARTS IDENTIFICATION)  
MOUNT PLATE HEAT EXCHANGER TO HANGER PLATE (019-3941-00-0) ON PUMP BODY USING (4) 7/16 SPRIT (087-0180-00-0) AND (6) LOCKWASHERS (018-2422-08-0) FOR HEAT EXCHANGER.  
OPTIONAL MOUNTING LOCATION WHEN BOTTOM MOUNT MIN IS INSTALLED.

USLIFE STRAINER ASSEMBLY (610-0150-02-0)  
STRAINER MUST BE MOUNTED TO PUMP PANEL (SEE PLATE PL774) AND HAS THE FOLLOWING HEIGHTS INSTALLED AND CONNECTED:  
018-2655-02-0 ELBOW 3/4 MNPT X 3/8 TUBE COMPRESSION (4)  
082-0533-02-0 TEE 3/4 FNPT EXTRUDED BRASS  
082-0501-02-0 NIPPLE 3/4 NPT BRASS  
ASSEMBLY CONSISTS OF ALL NECESSARY PARTS FOR STRAINER USE.

OIL FILTER ADAPTER AND OIL FILTER (SEE NOTE 1)  
INSTALL OIL FILTER ADAPTER (087-0024-00-0) ONTO OIL FILTER MOUNTING BRACKET (019-3950-00-0) USING (2) 3/8-16 X 1-1/4 LG SCREWS (018-1612-02-0), (2) 3/8 LOCK WASHERS (087-0140-01-0) AND (2) 3/8-16 NUTS (110-1600-02-0).  
INSTALL (014116-01) (W SEAL RING) X 1.516 JC FITTING (082-3041-01-0) ONTO OIL FILTER ADAPTER TOP OUTLET PORT.  
INSTALL (011-16-12 (W SEAL RING) X 1-5/16 JIC ELBOW (082-4028-08-0) INTO OIL FILTER ADAPTER BOTTOM INLET PORT.  
INSTALL PLUGS INTO UNUSED ADAPTER PORTS.  
INSTALL OIL FILTER (010-0650-01-0)

- NOTES:
- ENSURE PUMP HAS BRACKETS AND TANK PAD INSTALLED PER PL887 PRIOR TO ADDING CAFS READY COMPONENTS. DO NOT INSTALL TANK BRACKET OR TANK PAD TO THE PUMP BODY. SEE PLATE PL1000 FOR THE TBM SYSTEM SHOWN FOR REFERENCE ONLY.
  - APPLY LOCOTITE 246 OR EQUAL TO ALL SCREW THREADS.
  - APPLY LOCOTITE P57 OR EQUAL TO ALL PIPE THREADS.
  - SEE PLATE FSG-PL-01308 FOR HOSE CONNECTIONS SCHEMATIC.

ECN	REV	ZONE	CHANGED FROM	BY	DATE	APPROVED BY
1	2		REVISED	RP	02/25/14	
1	2		UPDATED VIEWS & NOTES	RP	02/20/14	HAL

REV	ZONE	DATE	APPROVED BY
1	2	02/25/14	RP
1	2	02/20/14	HAL

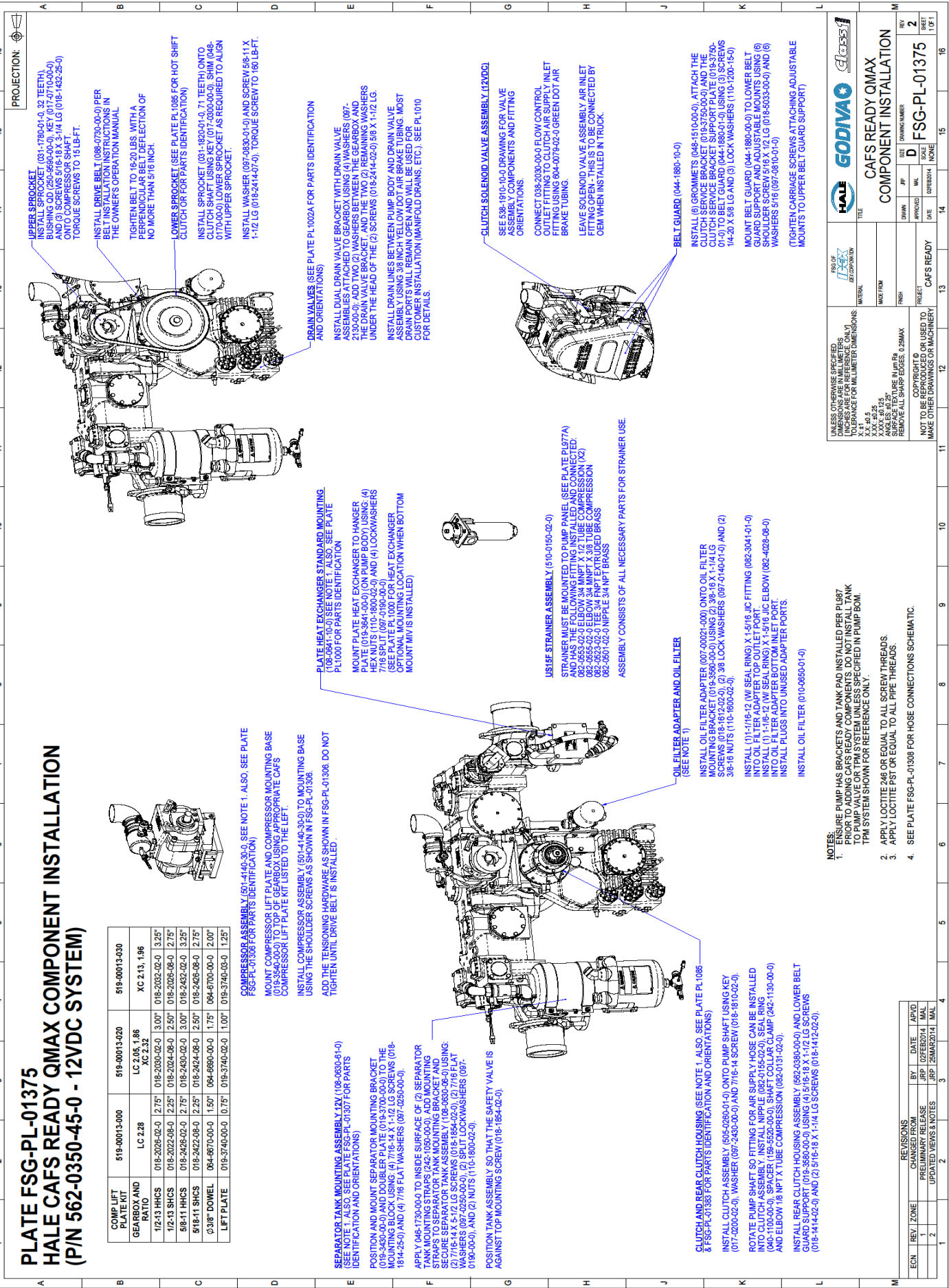

**UPPER SPROCKET**  
INSTALL SPROCKET (031-1780-01-32, TEETH) BUSHING OD (250-5690-00-0), KEY (017-0170-00-0) AND (3) SCREWS 5/16-18 X 3-1/4 LG (018-1432-25-0) ONTO COMPRESSOR SHAFT.  
TORQUE SCREWS TO 15 LBF.

**BELT INSTALLATION**  
INSTALL DRIVE BELT (088-0750-00-0) PER BELT INSTALLATION INSTRUCTIONS IN THE OWNER'S OPERATION MANUAL.  
TIGHTEN BELT TO 45-50 LBS WITH A PUMP MOTOR. BELT DEFLECTION OF NO MORE THAN 5/16 INCH.

**LOWER SPROCKET**  
SEE PLATE PL1086 FOR HOT SHIFT CLUTCH OR FOR PARTS IDENTIFICATION)  
INSTALL SPROCKET (031-1820-01-71, TEETH) ONTO CLUTCH SHAFT USING KEY (017-0000-00-0), SHIM (048-0000-00-0), AND LOCKWASHER AS REQUIRED TO ALIGN WITH UPPER SPROCKET.

**DRAIN VALVES** (SEE PLATE PL1002A FOR PARTS IDENTIFICATION AND ORIENTATIONS)  
INSTALL DUAL DRAIN VALVE BRACKET WITH DRAIN VALVE ASSEMBLY ATTACHED TO GEARBOX USING (4) WASHERS (087-2130-00-0), ADD TWO (2) WASHERS BETWEEN THE GEARBOX AND THE DRAIN VALVE BRACKET, AND THE TWO (2) REMAINING WASHERS UNDER THE HEAD OF THE (2) SCREWS (019-2414-02-0) 3/8 X 1-1/2 LG.

**DRAIN PORTS**  
INSTALL DRAIN LINES BETWEEN PUMP BODY AND DRAIN VALVE ASSEMBLY USING 3/8 INCH YELLOW DOT AIR BRAKE TUBING. MOST DRAIN PORTS WILL REMAIN OPEN AND WILL BE USED FOR PARTS IDENTIFICATION (MANIFOLD DRAINS, ETC.). SEE PL1010 FOR DETAILS.

**CLUTCH SOLENOID VALVE ASSEMBLY (1742Q)**  
SEE 538-1910-10-0 DRAWING FOR VALVE ASSEMBLY COMPONENTS AND FITTING ORIENTATIONS.  
CONNECT 038-2038-00-0 FLOW CONTROL OUTLET FITTING TO CLUTCH AIR SUPPLY INLET FITTING USING 804-0079-02-0 GREEN DOT AIR BRAKE TUBING.  
LEAVE SOLENOID VALVE ASSEMBLY AIR INLET FITTING OPEN. THIS IS TO BE CONNECTED BY OEM WHEN INSTALLED IN TRUCK.

**BELT GUARD** (044-1880-10-0)  
INSTALL (6) GROMMETS (048-1510-00-0), ATTACH THE CLUTCH SERVICE BRACKET TO THE BELT GUARD USING (2) BELT GUARD (044-1880-01-0) USING (3) SCREWS (114-20-12 X 8 LG AND (3) LOCK WASHERS (110-1200-15-0) MOUNT BELT GUARD (044-1880-01-0) OVER BELT GUARD SUPPORT AND ADJUSTABLE MOUNTS USING (6) SHOULDERS (018-5116-12) (2) LG (018-5033-00-0) AND (6) WASHERS 5/16 (087-0810-01-0) (TIGHTEN CARTRIDGE SCREWS ATTACHING ADJUSTABLE MOUNTS TO UPPER BELT GUARD SUPPORT)

**BEARING**  
SEE 538-1910-10-0 DRAWING FOR VALVE ASSEMBLY COMPONENTS AND FITTING ORIENTATIONS.  
CONNECT 038-2038-00-0 FLOW CONTROL OUTLET FITTING TO CLUTCH AIR SUPPLY INLET FITTING USING 804-0079-02-0 GREEN DOT AIR BRAKE TUBING.  
LEAVE SOLENOID VALVE ASSEMBLY AIR INLET FITTING OPEN. THIS IS TO BE CONNECTED BY OEM WHEN INSTALLED IN TRUCK.

**BELT GUARD** (044-1880-10-0)  
INSTALL (6) GROMMETS (048-1510-00-0), ATTACH THE CLUTCH SERVICE BRACKET TO THE BELT GUARD USING (2) BELT GUARD (044-1880-01-0) USING (3) SCREWS (114-20-12 X 8 LG AND (3) LOCK WASHERS (110-1200-15-0) MOUNT BELT GUARD (044-1880-01-0) OVER BELT GUARD SUPPORT AND ADJUSTABLE MOUNTS USING (6) SHOULDERS (018-5116-12) (2) LG (018-5033-00-0) AND (6) WASHERS 5/16 (087-0810-01-0) (TIGHTEN CARTRIDGE SCREWS ATTACHING ADJUSTABLE MOUNTS TO UPPER BELT GUARD SUPPORT)

**BEARING**  
SEE 538-1910-10-0 DRAWING FOR VALVE ASSEMBLY COMPONENTS AND FITTING ORIENTATIONS.  
CONNECT 038-2038-00-0 FLOW CONTROL OUTLET FITTING TO CLUTCH AIR SUPPLY INLET FITTING USING 804-0079-02-0 GREEN DOT AIR BRAKE TUBING.  
LEAVE SOLENOID VALVE ASSEMBLY AIR INLET FITTING OPEN. THIS IS TO BE CONNECTED BY OEM WHEN INSTALLED IN TRUCK.

**BELT GUARD** (044-1880-10-0)  
INSTALL (6) GROMMETS (048-1510-00-0), ATTACH THE CLUTCH SERVICE BRACKET TO THE BELT GUARD USING (2) BELT GUARD (044-1880-01-0) USING (3) SCREWS (114-20-12 X 8 LG AND (3) LOCK WASHERS (110-1200-15-0) MOUNT BELT GUARD (044-1880-01-0) OVER BELT GUARD SUPPORT AND ADJUSTABLE MOUNTS USING (6) SHOULDERS (018-5116-12) (2) LG (018-5033-00-0) AND (6) WASHERS 5/16 (087-0810-01-0) (TIGHTEN CARTRIDGE SCREWS ATTACHING ADJUSTABLE MOUNTS TO UPPER BELT GUARD SUPPORT)

**BELT GUARD** (044-1880-10-0)  
INSTALL (6) GROMMETS (048-1510-00-0), ATTACH THE CLUTCH SERVICE BRACKET TO THE BELT GUARD USING (2) BELT GUARD (044-1880-01-0) USING (3) SCREWS (114-20-12 X 8 LG AND (3) LOCK WASHERS (110-1200-15-0) MOUNT BELT GUARD (044-1880-01-0) OVER BELT GUARD SUPPORT AND ADJUSTABLE MOUNTS USING (6) SHOULDERS (018-5116-12) (2) LG (018-5033-00-0) AND (6) WASHERS 5/16 (087-0810-01-0) (TIGHTEN CARTRIDGE SCREWS ATTACHING ADJUSTABLE MOUNTS TO UPPER BELT GUARD SUPPORT)

**BELT GUARD** (044-1880-10-0)  
INSTALL (6) GROMMETS (048-1510-00-0), ATTACH THE CLUTCH SERVICE BRACKET TO THE BELT GUARD USING (2) BELT GUARD (044-1880-01-0) USING (3) SCREWS (114-20-12 X 8 LG AND (3) LOCK WASHERS (110-1200-15-0) MOUNT BELT GUARD (044-1880-01-0) OVER BELT GUARD SUPPORT AND ADJUSTABLE MOUNTS USING (6) SHOULDERS (018-5116-12) (2) LG (018-5033-00-0) AND (6) WASHERS 5/16 (087-0810-01-0) (TIGHTEN CARTRIDGE SCREWS ATTACHING ADJUSTABLE MOUNTS TO UPPER BELT GUARD SUPPORT)

**BELT GUARD** (044-1880-10-0)  
INSTALL (6) GROMMETS (048-1510-00-0), ATTACH THE CLUTCH SERVICE BRACKET TO THE BELT GUARD USING (2) BELT GUARD (044-1880-01-0) USING (3) SCREWS (114-20-12 X 8 LG AND (3) LOCK WASHERS (110-1200-15-0) MOUNT BELT GUARD (044-1880-01-0) OVER BELT GUARD SUPPORT AND ADJUSTABLE MOUNTS USING (6) SHOULDERS (018-5116-12) (2) LG (018-5033-00-0) AND (6) WASHERS 5/16 (087-0810-01-0) (TIGHTEN CARTRIDGE SCREWS ATTACHING ADJUSTABLE MOUNTS TO UPPER BELT GUARD SUPPORT)

		<b>CAFSA READY QMAX COMPONENT INSTALLATION</b>
		TITLE
MATERIAL	MAKE FROM	DRAWING NUMBER
FINISH	APPROVED BY	DATE
REMOVE ALL SHARP EDGES 0.25MM R	PROJECT	MAKE OTHER DRAWINGS OR MACHINERY
X-1 X-2 X-3 X-4 X-5 X-6 X-7 X-8 X-9 X-10 X-11 X-12 X-13 X-14 X-15 X-16 X-17 X-18 X-19 X-20 X-21 X-22 X-23 X-24 X-25 X-26 X-27 X-28 X-29 X-30 X-31 X-32 X-33 X-34 X-35 X-36 X-37 X-38 X-39 X-40 X-41 X-42 X-43 X-44 X-45 X-46 X-47 X-48 X-49 X-50 X-51 X-52 X-53 X-54 X-55 X-56 X-57 X-58 X-59 X-60 X-61 X-62 X-63 X-64 X-65 X-66 X-67 X-68 X-69 X-70 X-71 X-72 X-73 X-74 X-75 X-76 X-77 X-78 X-79 X-80 X-81 X-82 X-83 X-84 X-85 X-86 X-87 X-88 X-89 X-90 X-91 X-92 X-93 X-94 X-95 X-96 X-97 X-98 X-99 X-100 X-101 X-102 X-103 X-104 X-105 X-106 X-107 X-108 X-109 X-110 X-111 X-112 X-113 X-114 X-115 X-116 X-117 X-118 X-119 X-120 X-121 X-122 X-123 X-124 X-125 X-126 X-127 X-128 X-129 X-130 X-131 X-132 X-133 X-134 X-135 X-136 X-137 X-138 X-139 X-140 X-141 X-142 X-143 X-144 X-145 X-146 X-147 X-148 X-149 X-150 X-151 X-152 X-153 X-154 X-155 X-156 X-157 X-158 X-159 X-160 X-161 X-162 X-163 X-164 X-165 X-166 X-167 X-168 X-169 X-170 X-171 X-172 X-173 X-174 X-175 X-176 X-177 X-178 X-179 X-180 X-181 X-182 X-183 X-184 X-185 X-186 X-187 X-188 X-189 X-190 X-191 X-192 X-193 X-194 X-195 X-196 X-197 X-198 X-199 X-200 X-201 X-202 X-203 X-204 X-205 X-206 X-207 X-208 X-209 X-210 X-211 X-212 X-213 X-214 X-215 X-216 X-217 X-218 X-219 X-220 X-221 X-222 X-223 X-224 X-225 X-226 X-227 X-228 X-229 X-230 X-231 X-232 X-233 X-234 X-235 X-236 X-237 X-238 X-239 X-240 X-241 X-242 X-243 X-244 X-245 X-246 X-247 X-248 X-249 X-250 X-251 X-252 X-253 X-254 X-255 X-256 X-257 X-258 X-259 X-260 X-261 X-262 X-263 X-264 X-265 X-266 X-267 X-268 X-269 X-270 X-271 X-272 X-273 X-274 X-275 X-276 X-277 X-278 X-279 X-280 X-281 X-282 X-283 X-284 X-285 X-286 X-287 X-288 X-289 X-290 X-291 X-292 X-293 X-294 X-295 X-296 X-297 X-298 X-299 X-300 X-301 X-302 X-303 X-304 X-305 X-306 X-307 X-308 X-309 X-310 X-311 X-312 X-313 X-314 X-315 X-316 X-317 X-318 X-319 X-320 X-321 X-322 X-323 X-324 X-325 X-326 X-327 X-328 X-329 X-330 X-331 X-332 X-333 X-334 X-335 X-336 X-337 X-338 X-339 X-340 X-341 X-342 X-343 X-344 X-345 X-346 X-347 X-348 X-349 X-350 X-351 X-352 X-353 X-354 X-355 X-356 X-357 X-358 X-359 X-360 X-361 X-362 X-363 X-364 X-365 X-366 X-367 X-368 X-369 X-370 X-371 X-372 X-373 X-374 X-375 X-376 X-377 X-378 X-379 X-380 X-381 X-382 X-383 X-384 X-385 X-386 X-387 X-388 X-389 X-390 X-391 X-392 X-393 X-394 X-395 X-396 X-397 X-398 X-399 X-400 X-401 X-402 X-403 X-404 X-405 X-406 X-407 X-408 X-409 X-410 X-411 X-412 X-413 X-414 X-415 X-416 X-417 X-418 X-419 X-420 X-421 X-422 X-423 X-424 X-425 X-426 X-427 X-428 X-429 X-430 X-431 X-432 X-433 X-434 X-435 X-436 X-437 X-438 X-439 X-440 X-441 X-442 X-443 X-444 X-445 X-446 X-447 X-448 X-449 X-450 X-451 X-452 X-453 X-454 X-455 X-456 X-457 X-458 X-459 X-460 X-461 X-462 X-463 X-464 X-465 X-466 X-467 X-468 X-469 X-470 X-471 X-472 X-473 X-474 X-475 X-476 X-477 X-478 X-479 X-480 X-481 X-482 X-483 X-484 X-485 X-486 X-487 X-488 X-489 X-490 X-491 X-492 X-493 X-494 X-495 X-496 X-497 X-498 X-499 X-500 X-501 X-502 X-503 X-504 X-505 X-506 X-507 X-508 X-509 X-510 X-511 X-512 X-513 X-514 X-515 X-516 X-517 X-518 X-519 X-520 X-521 X-522 X-523 X-524 X-525 X-526 X-527 X-528 X-529 X-530 X-531 X-532 X-533 X-534 X-535 X-536 X-537 X-538 X-539 X-540 X-541 X-542 X-543 X-544 X-545 X-546 X-547 X-548 X-549 X-550 X-551 X-552 X-553 X-554 X-555 X-556 X-557 X-558 X-559 X-560 X-561 X-562 X-563 X-564 X-565 X-566 X-567 X-568 X-569 X-570 X-571 X-572 X-573 X-574 X-575 X-576 X-577 X-578 X-579 X-580 X-581 X-582 X-583 X-584 X-585 X-586 X-587 X-588 X-589 X-590 X-591 X-592 X-593 X-594 X-595 X-596 X-597 X-598 X-599 X-600 X-601 X-602 X-603 X-604 X-605 X-606 X-607 X-608 X-609 X-610 X-611 X-612 X-613 X-614 X-615 X-616 X-617 X-618 X-619 X-620 X-621 X-622 X-623 X-624 X-625 X-626 X-627 X-628 X-629 X-630 X-631 X-632 X-633 X-634 X-635 X-636 X-637 X-638 X-639 X-640 X-641 X-642 X-643 X-644 X-645 X-646 X-647 X-648 X-649 X-650 X-651 X-652 X-653 X-654 X-655 X-656 X-657 X-658 X-659 X-660 X-661 X-662 X-663 X-664 X-665 X-666 X-667 X-668 X-669 X-670 X-671 X-672 X-673 X-674 X-675 X-676 X-677 X-678 X-679 X-680 X-681 X-682 X-683 X-684 X-685 X-686 X-687 X-688 X-689 X-690 X-691 X-692 X-693 X-694 X-695 X-696 X-697 X-698 X-699 X-700 X-701 X-702 X-703 X-704 X-705 X-706 X-707 X-708 X-709 X-710 X-711 X-712 X-713 X-714 X-715 X-716 X-717 X-718 X-719 X-720 X-721 X-722 X-723 X-724 X-725 X-726 X-727 X-728 X-729 X-730 X-731 X-732 X-733 X-734 X-735 X-736 X-737 X-738 X-739 X-740 X-741 X-742 X-743 X-744 X-745 X-746 X-747 X-748 X-749 X-750 X-751 X-752 X-753 X-754 X-755 X-756 X-757 X-758 X-759 X-760 X-761 X-762 X-763 X-764 X-765 X-766 X-767 X-768 X-769 X-770 X-771 X-772 X-773 X-774 X-775 X-776 X-777 X-778 X-779 X-780 X-781 X-782 X-783 X-784 X-785 X-786 X-787 X-788 X-789 X-790 X-791 X-792 X-793 X-794 X-795 X-796 X-797 X-798 X-799 X-800 X-801 X-802 X-803 X-804 X-805 X-806 X-807 X-808 X-809 X-810 X-811 X-812 X-813 X-814 X-815 X-816 X-817 X-818 X-819 X-820 X-821 X-822 X-823 X-824 X-825 X-826 X-827 X-828 X-829 X-830 X-831 X-832 X-833 X-834 X-835 X-836 X-837 X-838 X-839 X-840 X-841 X-842 X-843 X-844 X-845 X-846 X-847 X-848 X-849 X-850 X-851 X-852 X-853 X-854 X-855 X-856 X-857 X-858 X-859 X-860 X-861 X-862 X-863 X-864 X-865 X-866 X-867 X-868 X-869 X-870 X-871 X-872 X-873 X-874 X-875 X-876		

# SMARTCAFS200 WIRING HARNESS

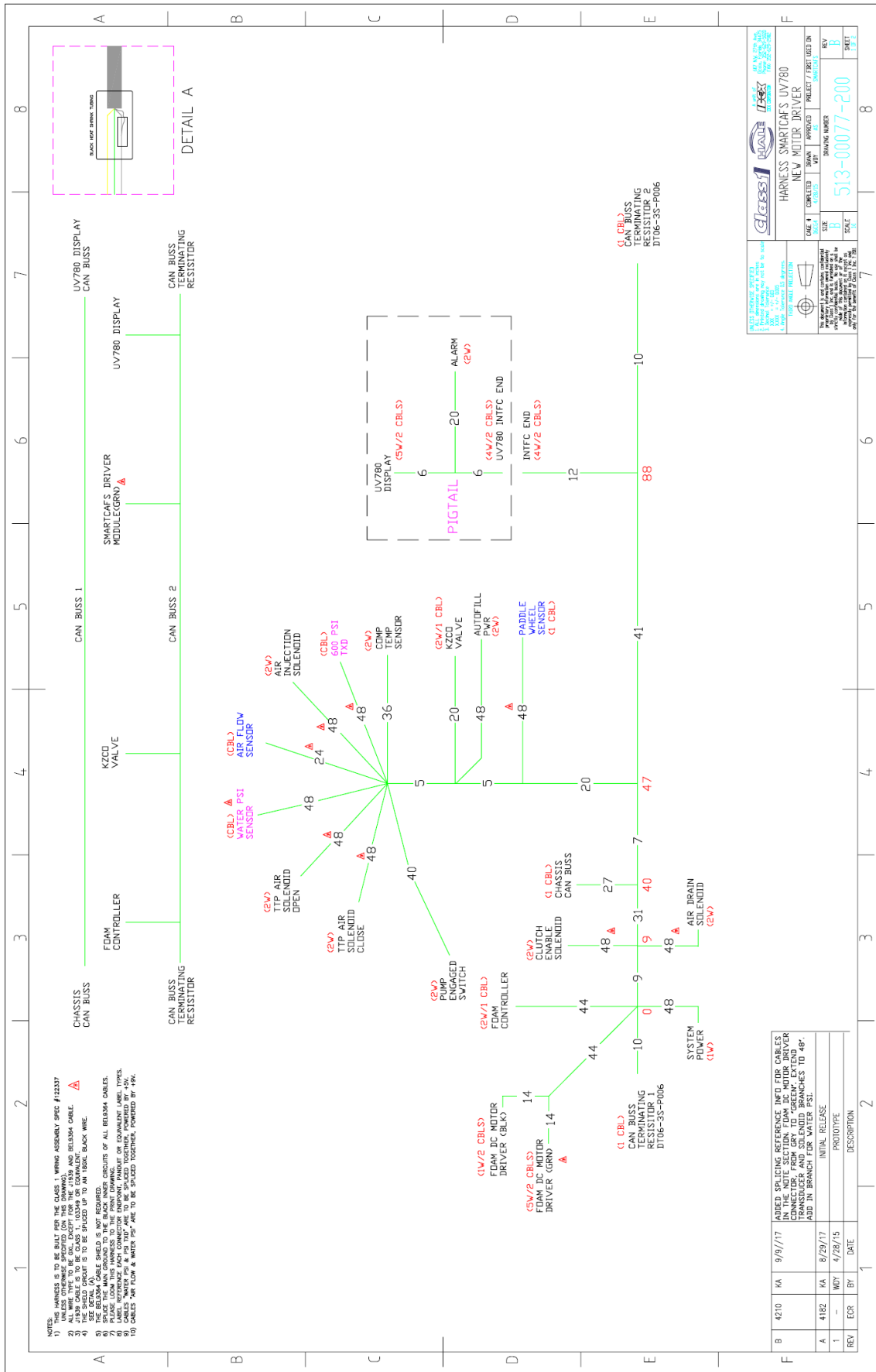

- NOTES:
- 1) THIS HARNESS IS TO BE BUILT PER THE CLASS 1 WIRING ASSEMBLY SPEC #12337 UNLESS OTHERWISE SPECIFIED (ON THIS DRAWING).
  - 2) 21AW CABLE IS TO BE CLASS 1, 100249 OR EQUIVALENT. **A**
  - 3) 21AW CABLE IS TO BE CLASS 1, 100249 OR EQUIVALENT.
  - 4) SEE DETAIL 'A'.
  - 5) BRACKET THE MAIN GROUND TO THE BACK WING CIRCUITS OF ALL RELAY CABLES.
  - 6) BRACKET THE MAIN GROUND TO THE BACK WING CIRCUITS OF ALL RELAY CABLES.
  - 7) PLEASE LOOK THIS HARNESS TO THE FRONT END OF THE EQUIPMENT OR EQUIVALENT LABEL TYPES.
  - 8) CABLES WATER PSI & PSI TRIP ARE TO BE SPACED TOGETHER, POWERED BY 2W.
  - 9) CABLES TTP OPEN & TTP CLOSE ARE TO BE SPACED TOGETHER, POWERED BY 2W.
  - 10) CABLES FOR FCAM & WATER PSI ARE TO BE SPACED TOGETHER, POWERED BY 4W.

<b>HARNESS SMARTCAFS UV780</b> <b>NEW MOTOR DRIVER</b>	
CASE # 513-00077-200	PROJECT / FIRST USE IN 197
SCALE B	REV B
SHEET 197	

REV	ECR	BY	DATE	DESCRIPTION
B	4210	KA	9/9/17	LATEST REV. USING REFERENCED INLET FOR CABLES IN THE NOTE SECTION FDM DC MOTOR DRIVER CONNECTOR FROM GRN TO GREEN, EXTENDING TO 46".
A	4182	KA	8/29/17	INITIAL RELEASE
1		MOY	4/28/15	PROTOTYPE





# THERMAL RELIEF VALVE

### TEST PROCEDURE

- CLOSE ALL DISCHARGE VALVES INCLUDING PUMP THROUGH THE 1/8" NPT OR ISO DISCHARGE VALVE TO THE TRUCK TANK.
- START THE PUMP AND CHECK FOR LEAKS. THE THERMAL RELIEF VALVE WILL OPEN FASTER ON SMALLER PUMPS. ON 207R (21°C) WATER AND RELIEF VALVE WILL OPEN FASTER IN HOTTER UNITS. ALLOW WATER TO COOL TO 100°F (38°C) TO 1-2 GPM OF WATER BEFORE PUMP TURNS ON.
- THIS SCREW IS PRESET AND LOCKED IN PLACE. IF A PART OF THE RELIEF VALVE IS REPLACED IT MAY NEED READJUSTMENT. ATTACH A WATER SUPPLY OF 30-60 PSIG (2-4 BARS) TO THE 1/8" NPT OR ISO HOLE. APPLY A THREAD SEALING ADHESIVE TO THE THREADS AND TURN SCREW CLOCKWISE UNTIL INKING WATER PASSES THRU HOLE "X" AND STARTS TO FLOW OUT OF THE STRAINER. AT THIS POINT, TURN THE ADJUSTING SCREW COUNTERCLOCKWISE 2-1/2 TURNS SO THE FLOW STOPS AND THE PISTON IS POSITIONED.
- 1/8" N.P.T. OR ISO 228/1-G 1/8 CONNECTION FOR RELIEF VALVE DISCHARGE LINE. USE 3/8 (1.0) TUBING TO ATMOSPHERE OR RETURN LINE TO THE TRUCK TANK. A DRAIN VALVE MUST BE PROVIDED IN THIS LINE TO DRAIN IN FREEZING WEATHER. IF THE VALVE IS MOUNTED HORIZONTAL, THIS CONNECTION SHOULD BE IN A DOWNWARD POSITION TO AID IN DRAINING OF THE TUBING LINE.

### TRV-L KIT

3/8 SCALE

INSTALL THIS END IN UPWARDS POSITION SO THE RELIEF VALVE DRAINS IN FREEZING WEATHER OR USE DRAIN AS NOTED.

OPTIONAL AUDIBLE ALARM

POWER CONNECTION THRU 10 AMP 12V FUSE

TO CHASSIS GROUND (1/4 GA. SW. DR. GAL. SAE J1128)

TO CHASSIS GROUND

TO CHASSIS GROUND (1/4 GA. SW. DR. GAL. SAE J1128)

513-0361-01-0 WIRE HARNESS

200-0540-15-0 TRV-L TRV BODY

200-0540-00-0 BULB

200-0540-13-0 RED LENS

200-1450-00-0 TRV-L TEST SWITCH

101-1720-00-0 TRV-L NAMEPLATE

TO CHASSIS GROUND (1/4 GA. SW. DR. GAL. SAE J1128)

2.75 [70] CONNECTION FOR RELIEF VALVE DISCHARGE LINE

5.75 MIN. [114] CLEARANCE FOR CURVED WIRES

200-2550-00-0 PRESSURE SWITCH

082-0145-02-0 ELBOW

082-0146-02-0 FITTING

REMOVE 1/8" N.P.T. PLUG

**NOTE**

- TRV-L KIT 594, 200-2550-00-0 DOES NOT INCLUDE TRV.
- TRV-L KIT CAN ONLY BE USED ON TRV UNITS MANUFACTURED AFTER 2/1/97. TRVS MUST HAVE SECOND 1/8" N.P.T. TAP AS SHOWN.
- REMOVE 1/8" N.P.T. PLUG WHEN INSTALLING TRV-L KIT.

038-1280-03-0 BODY WITH 1-1/4" N.P.T. THREAD INSTALL ON PUMP DISCHARGE MANIFOLD. THE THERMAL RELIEF VALVE IS INSTALLED IN THE PUMP DISCHARGE PIPING. MOUNT CLOSE TO THE PUMP BODY OUTLET.

APPLY LOC TITE PST OR EQUAL BEFORE ASSEMBLY.

HOLE "X"

217-0101-13-0 1/8 NPT PLUG (SEE NOTE C)

077-9024-20-0 RETAINING RING

073-0100-00-0 PISTON

042-0540-00-0 SPRING

077-1180-20-0 RETAINING RING

MOUNTING FACE FOR REFERENCE ONLY

038-1280-03-0 BODY WITH 1-1/4" N.P.T. THREAD INSTALL ON PUMP DISCHARGE MANIFOLD. THE THERMAL RELIEF VALVE IS INSTALLED IN THE PUMP DISCHARGE PIPING. MOUNT CLOSE TO THE PUMP BODY OUTLET.

APPLY LOC TITE PST OR EQUAL BEFORE ASSEMBLY.

038-1280-03-0 BODY WITH 1-1/4" N.P.T. THREAD INSTALL ON PUMP DISCHARGE MANIFOLD. THE THERMAL RELIEF VALVE IS INSTALLED IN THE PUMP DISCHARGE PIPING. MOUNT CLOSE TO THE PUMP BODY OUTLET.

APPLY LOC TITE PST OR EQUAL BEFORE ASSEMBLY.

TRV PANEL MOUNT OUT

3/8 SCALE

1.00 [25] (2X) .45 [11] (2X) .75 [19] TRV NAMEPLATE

1.00 [25] (2X) .24 [6] (2X) .24 [6]

SENSING ELEMENT 038-1251-00-0 (120°F [49°C])

038-1251-01-0 (170°F [177°C])

064-0322-02-0 SPRING PIN

## HALE TYPE TRV/TRVM THERMAL RELIEF VALVE

ECO NO. REV	CHANGED FROM	BY	DATE	APVD	ECO NO. REV	CHANGED FROM	BY	DATE	APVD
1034	I ADDED INTERMEDIATE HARNESS DRS	11-23-10	PRO	00-5501	E	ADDED TRV WITH FLANGE (TRV) / DK	07-31-00	MAL	APVD
				04-1061	F	ADDED 082-0145-02-0 ELBOW 082-0146-02-0 FITTING	05-16-04	MAL	TC
				0128	G	ADDED 200-1310-03-0 ALARM	AB 7-1-05	MAL	AB
				0593	H	ADDED PANEL MOUNT CUT OUT VIEW	6-1-07	MAL	KSM

PLATE NO. 729AI

PATENT NO. 5,018,665

HALE PRODUCTS, INC.  
A Unit of IDEX Corporation  
Conshohocken, PA 19428 USA

TEMPERATURE RATING

TRV120/TRVM120 120° F. [49° C]

TRV170/TRVM170 170° F. [77° C]

# PARTS LIST – SUCTION MANIFOLD

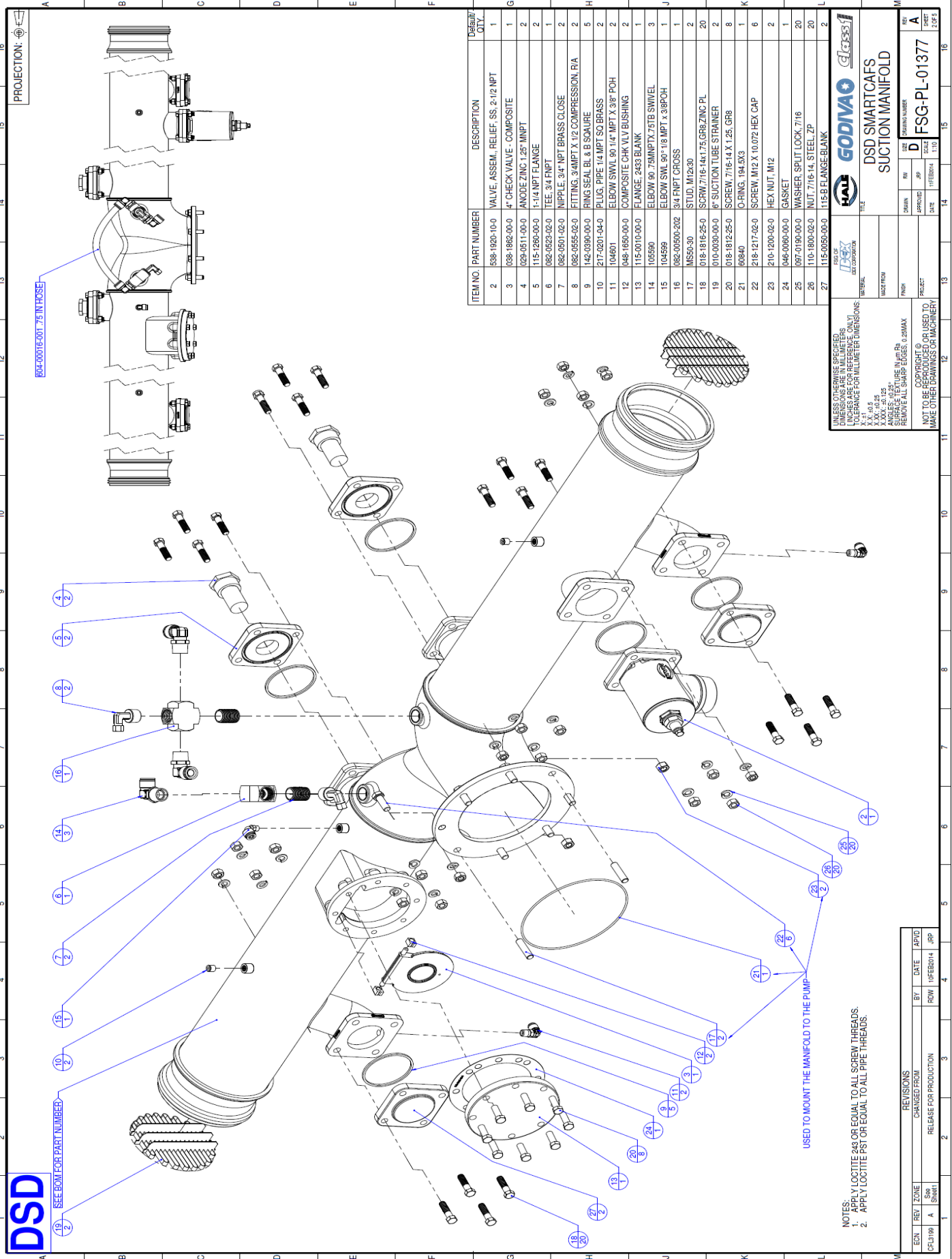

ITEM NO.	PART NUMBER	DESCRIPTION	Default QTY.
2	538-1820-10-0	VALVE, ASSEM. RELIEF, SS, 2-1/2 NPT	1
3	1038-1862-00-0	4" CHECK VALVE - COMPOSITE	2
4	029-0511-00-0	ANODE ZINC 1.25" MNPT	1
5	115-1260-00-0	1-1/4 NPT FLANGE	2
6	082-0523-02-0	TEE, 3/4 FNPT	1
7	082-0501-02-0	NIPPLE, 3/4" NPT BRASS CLOSE	2
8	082-0555-02-0	FITTING, 3/4MNPT X 1/2 COMPRESSION, R/A	2
9	142-0390-00-0	RING SEAL BL & B SOAURE	5
10	217-0201-04-0	PLUG, PIPE, 1/4" NPT SQ BRASS	2
11	104601	ELBOW SWL 90, 1/4" NPT X 3/8" POH	2
12	048-1650-00-0	COMPOSITE GSK/VLV BUSHING	2
13	115-0010-00-0	FLANGE, 2453 BLANK	1
14	106590	ELBOW 90, 7/8MNPT X 7/8 SWWEL	3
15	104599	ELBOW SWL 90, 1/8" NPT X 3/8 POH	1
16	082-0050-202	3/4 FNPT CROSS	1
17	MS50-30	STUD, M12X30	20
18	018-1812-25-0	SCREW, 7/16-14 X 1.25, GR8, ZINC PL	2
19	010-0030-00-0	8" SUCTION TUBE STRAINER	2
20	018-1812-25-0	SCREW, 7/16-14 X 1.25, GR8	8
21	60840	O-RING, 194, 5X3	1
22	218-1217-02-0	SCREW, M12 X 10, 072 HEX, CAP	6
23	210-1200-02-0	HEX NUT, M12	2
24	046-0060-00-0	GASKET	1
25	097-0190-00-0	WASHER, SPLIT LOCK, 7/16	20
26	110-1800-02-0	NUT, 7/16-14, STEEL, ZP	20
27	115-0050-00-0	115-B FLANGE-BLANK	2

**GODIVA** *diva*

**DSD SMARTCAFS**  
SUCTION MANIFOLD

DATE: \_\_\_\_\_ BY: \_\_\_\_\_  
 DRAWN: \_\_\_\_\_ REV: \_\_\_\_\_  
 PROJECT: \_\_\_\_\_ SCALE: \_\_\_\_\_  
 SHEET: \_\_\_\_\_ OF \_\_\_\_\_

FIG. OF \_\_\_\_\_  
 REV. OF \_\_\_\_\_

UNLESS OTHERWISE SPECIFIED, DIMENSIONS ARE IN MILLIMETERS. DIMENSIONS IN PARENTHESES ARE IN INCHES. DIMENSIONS FOR MILLIMETER DIMENSIONS: X.X, X.XX, X.XXX, X.XXXX. DIMENSIONS FOR INCH DIMENSIONS: X.X, X.XX, X.XXX, X.XXXX. REMOVE ALL SHARP EDGES, 0.25 MAX. NOT TO BE REPRODUCED OR USED TO MAKE OTHER DRAWINGS OR MACHINERY.

REV	DATE	BY	DESCRIPTION
A			RELEASE FOR PRODUCTION

REV	DATE	BY	DESCRIPTION
A			RELEASE FOR PRODUCTION

REV	DATE	BY	DESCRIPTION
A			RELEASE FOR PRODUCTION

REV	DATE	BY	DESCRIPTION
A			RELEASE FOR PRODUCTION

REV	DATE	BY	DESCRIPTION
A			RELEASE FOR PRODUCTION

REV	DATE	BY	DESCRIPTION
A			RELEASE FOR PRODUCTION

REV	DATE	BY	DESCRIPTION
A			RELEASE FOR PRODUCTION

REV	DATE	BY	DESCRIPTION
A			RELEASE FOR PRODUCTION

REV	DATE	BY	DESCRIPTION
A			RELEASE FOR PRODUCTION

REV	DATE	BY	DESCRIPTION
A			RELEASE FOR PRODUCTION

REV	DATE	BY	DESCRIPTION
A			RELEASE FOR PRODUCTION

REV	DATE	BY	DESCRIPTION
A			RELEASE FOR PRODUCTION

REV	DATE	BY	DESCRIPTION
A			RELEASE FOR PRODUCTION

REV	DATE	BY	DESCRIPTION
A			RELEASE FOR PRODUCTION

REV	DATE	BY	DESCRIPTION
A			RELEASE FOR PRODUCTION

REV	DATE	BY	DESCRIPTION
A			RELEASE FOR PRODUCTION

# PARTS LIST - DISCHARGE MANIFOLD

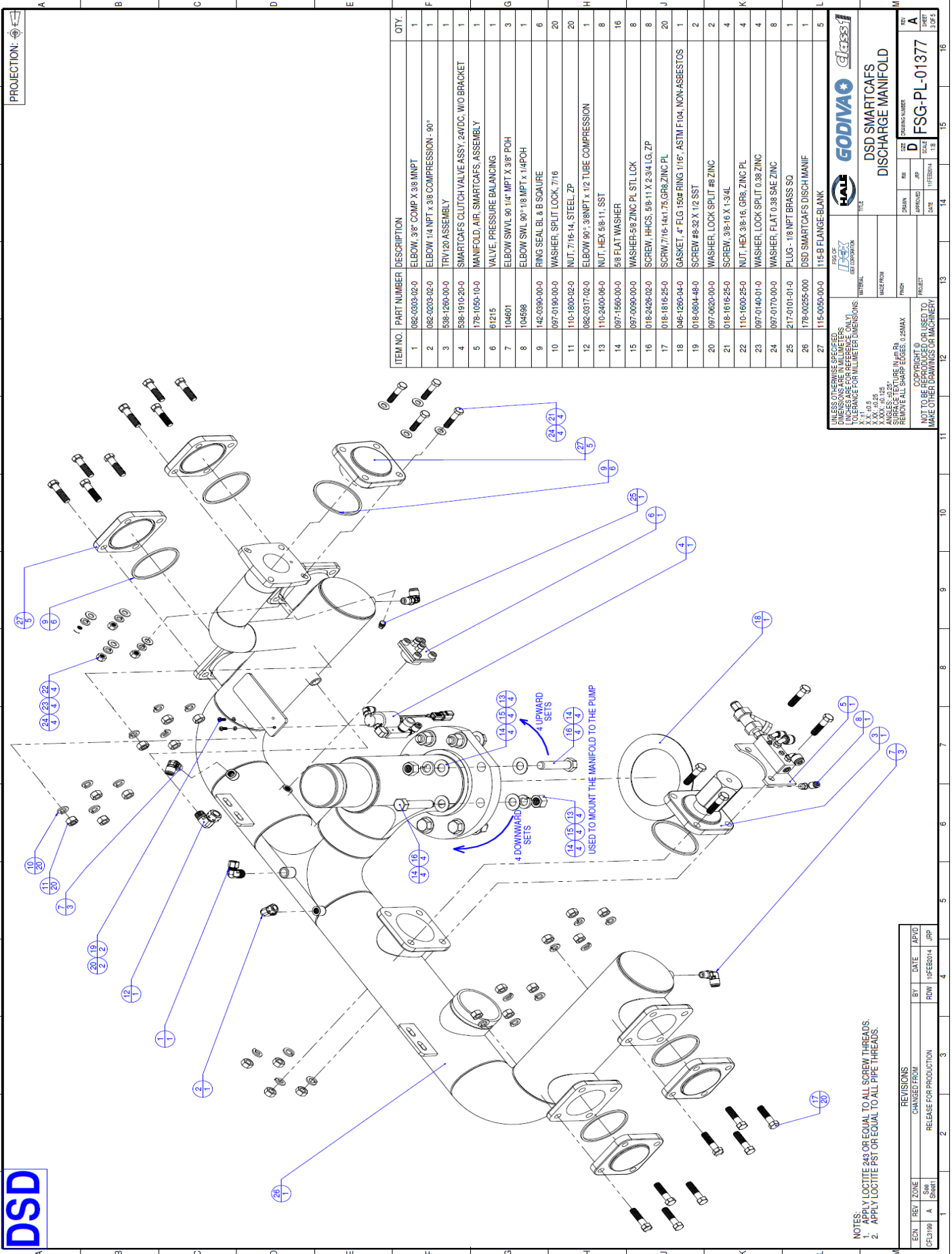

ITEM NO.	PART NUMBER	DESCRIPTION	QTY.
1	982-0303-02-0	ELBOW, 3/8" COMP X 3/8 MNPT	1
2	982-0203-02-0	ELBOW, 1/4" NPT X 3/8 COMPRESSION - 90°	1
3	538-1260-00-0	TRV120 ASSEMBLY	1
4	538-1910-20-0	SMARTCAFS CLUTCH VALVE ASSY, 24VDC, W/O BRACKET	1
5	178-1050-10-0	MANIFOLD, AIR, SMARTCAFS, ASSEMBLY	1
6	91215	VALVE, PRESSURE BALANCING	1
7	104601	ELBOW SWVL 90° 1/4" MPT X 3/8" POH	3
8	104698	ELBOW SWVL 90° 1/4" MPT X 1/4" POH	6
9	142-0390-00-0	RING SEAL BL & B SQAURE	1
10	997-0190-00-0	WASHER, SPLIT LOCK, 7/16	20
11	110-1800-02-0	NUT, 7/16-14, STEEL, ZP	20
12	982-0317-02-0	ELBOW 90°, 3/8NPT X 1/2 TUBE COMPRESSION	1
13	110-2400-06-0	NUT, HEX 5/8-11, SST	8
14	997-1560-00-0	5/8 FLAT WASHER	16
15	997-0090-00-0	WASHER, 5/8 ZINC PL STL LOCK	8
16	018-2426-02-0	SCREW, HHCS, 5/8-11 X 2-3/4 LG, ZP	8
17	018-1816-25-0	SCRW 7/16-14x1.75 GR8, ZINC PL	20
18	046-1260-04-0	GASKET, 4" FLG 150# RING 1/16", ASTM F104, NON-ASBESTOS	1
19	018-0604-48-0	SCREW #8-32 X 1/2 SST	2
20	997-0620-00-0	WASHER, LOCK SPLIT #8 ZINC	2
21	018-1616-25-0	SCREW, 3/8-16 X 1-3/4L	4
22	110-1600-25-0	NUT, HEX 3/8-16, GR8, ZINC PL	4
23	997-0140-01-0	WASHER, LOCK SPLIT 0.38 ZINC	4
24	997-0170-00-0	WASHER, FLAT 0.38 SAE ZINC	8
25	217-0101-01-0	PLUG - 1/8 NPT BRASS SQ	1
26	178-0025-00-0	DSD SMARTCAFS DISCH MANIF	1
27	115-0050-00-0	115 B FLANGE-BLANK	5

UNLESS OTHERWISE SPECIFIED, DIMENSIONS ARE PER REFERENCE ONLY. TOLERANCE FOR MILLIMETER DIMENSIONS IS ±0.13MM.

ISO OF IDEX CORPORATION

**GODIVA** **GLASS**

DSD SMARTCAFS DISCHARGE MANIFOLD

REV: D  
DATE: 10FEB2014

APPROVED BY: JRP  
DATE: 10FEB2014

DESIGNED BY: JRP  
DATE: 10FEB2014

ISSUED BY: JRP  
DATE: 10FEB2014

PROJECT: FSG-PL-01377

3 OF 3

NOTES:

- APPLY LOCITITE 243 OR EQUAL TO ALL SCREW THREADS.
- APPLY LOCITITE PST OR EQUAL TO ALL PIPE THREADS.

REV	ZONE	DATE	APTD
01	A	10FEB2014	JRP

REVISIONS

CHANGED FROM	BY	DATE	APTD
RELEASE FOR PRODUCTION	ROW	10FEB2014	JRP

**DSD**

# PARTS LIST – BELT GUARD & CAFS MIXING MANIFOLD

ITEM NO.	PART NUMBER	DESCRIPTION	QTY.
1	044-1880-01-1	CAFS-PRO BELT GUARD	1
2	019-3750-00-0	CLUTCH SERVICE BRACKET	1
3	097-0810-01-0	WASHER, FLAT 1/4 X .625 OD .04 THK SS	10
4	118-5033-00-0	SCREW, SHOULDER, 5/16 X 1/2 W/ 1/4-20 THREAD, S.S.	6
5	048-1510-00-0	GROMMET, 5/16" ID, 5/8" OD, 1/16" THICK FOR 1/2" DIAMETER PANEL HOLE	6
6	019-3750-01-0	SUPPORT PLATE, CLUTCH SERVICE BRACKET	1
7	118-1205-08-0	SCREW, 1/4-20 X 2.88 SDC, HD, CAP, S.S.	3
8	097-0020-01-0	WASHER, FLAT 1/4"	3
9	097-0300-01-0	WASHER 1/4 LOCK STEEL-ZINC	3
10	110-1200-02-0	NUT, HEX 1/4-20 ZINC	3
11	101-5290-01-0	DECAL, HAILE LOGO REFLECTIVE	1
12	101-1388-00-0	LABEL, CAUTION, SERVICE AREA SPACER	1
13	019-3580-01-0	LOWER BELT GUARD SUPPORT	1
14	018-1414-02-0	5/16-18 X 1.50 HEX	4
15	097-0560-01-0	WASHER, SPLIT, 5/16, ZP STEEL	4
16	018-1412-02-0	5/16-18 X 1.25 HEX HEAD CAP SCREWS	2

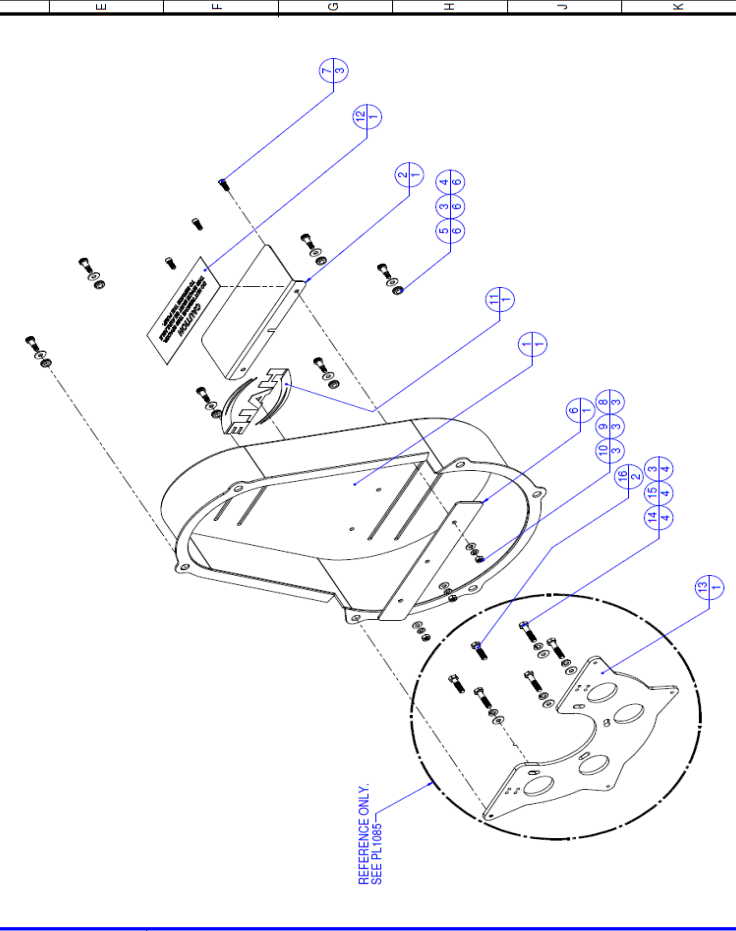

ITEM NO.	PART NUMBER	DESCRIPTION	QTY.
1	019-0957	SUPPORT BRKT, MIXING MANIF	1
2	538-1840-00-0	MANIFOLD ASSEMBLY CHECK 3"	1
3	088-0590-01-0	COUP VIC 3.0 RIGID PAINT 750	3
4	538-1900-00-0	VALVE, MANIFOLD, ARC, SMARTCAFS, 3"	1
5	102714	PADDLEWHEEL ASSEMBLY	1
6	178-00256-000	DSD SMARTCAFS MANIF	1
7	104601	ELBOW SWVL 90 1/4" MPT X 3/8" POH	1
8	038-1790-00-0	INJECTOR CHECK VALVE	1
9	110-1600-02-0	NUT, FINISHED 3/8-16 ZINC	4
10	018-1616-25-0	SCREW, 3/8-16 X 1.3/4	2
11	097-0140-01-0	WASHER, LOCK SPLIT 0.38 ZINC	4
12	097-0170-00-0	WASHER, FLAT 0.38 SAE ZINC	6
13	018-1612-25-0	SCREW, HHCS, 3/8-16 X 1-1/4, GRB, ZP	2

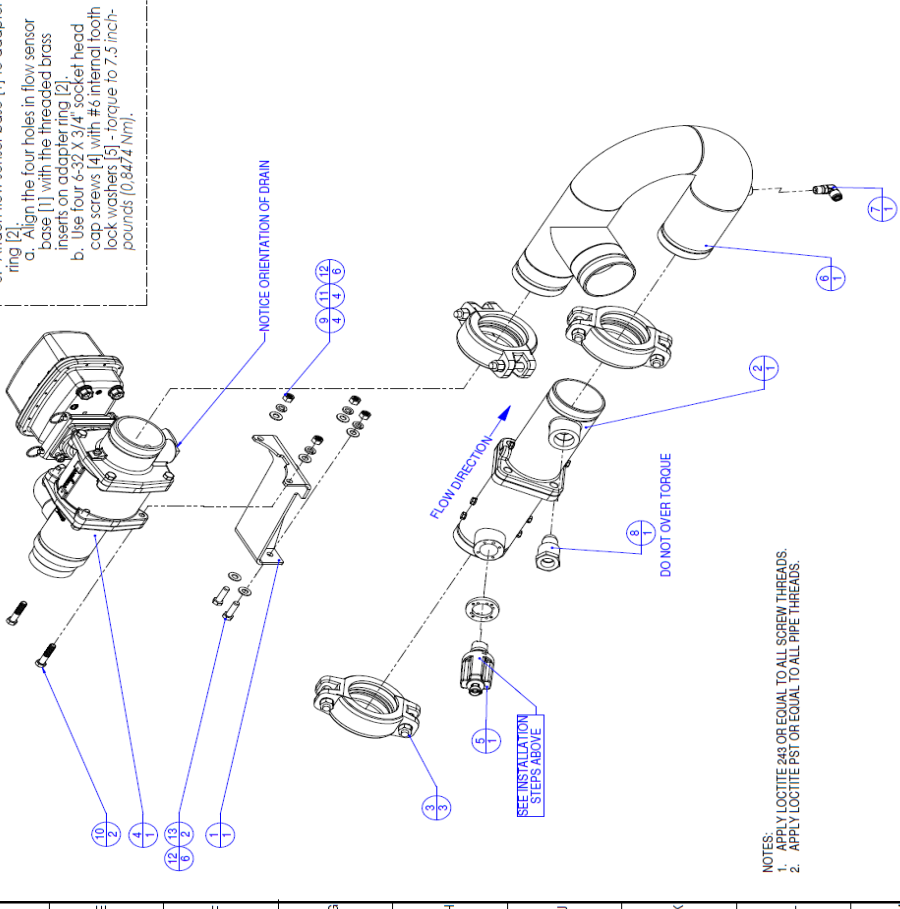

**TORQUE SPECIFICATION FOR 6-32 x 1/2" SOCKET HEAD CAP SCREWS**

MOUNT MATERIAL	Inches	Nm
ALUMINUM	5.3	0.60
BRASS	7.9	0.89
STEEL	9.0	1.02
STAINLESS STEEL	9.6	1.09
SADDLE CLAMP	8.5	0.96

**ITEM 5: PADDLEWHEEL ASSEMBLY --**  
**INSTALLATION STEPS:**  
 1. Attach adapter ring [2] to flow sensor mount on hanger or manifold.  
 a. Align adapter ring indexing pin with flow sensor mount indexing hole.  
 b. Use four 6-32 x 1/2" socket head cap screws [3] - see torque table above.  
 2. Insert flow sensor base [1] into adapter ring [2].  
 a. Orient flow sensor base [1] so that triangular notch is pointing in the direction of flow.  
 3. Attach flow sensor base [1] to adapter ring [2].  
 a. Align the four holes in flow sensor base [1] with the threaded brass inserts on adapter ring [2].  
 b. Use four 6-32 x 3/4" socket head cap screws [4] with #6 internal tooth lock washers [5] - torque to 7.5 inch-pounds (0.847 Nm).

NOTES:  
 1. APPLY LOCTITE 243 OR EQUAL TO ALL SCREW THREADS.  
 2. APPLY LOCTITE PST OR EQUAL TO ALL PIPE THREADS.

NOTES:  
 1. APPLY LOCTITE 243 OR EQUAL TO ALL SCREW THREADS.  
 2. APPLY LOCTITE PST OR EQUAL TO ALL PIPE THREADS.

<b>DSD SMARTCAFS MIXING MANIFOLD &amp; BELT GUARD</b>			
DSD DIVISION	REV A	DRAWING NUMBER D	SHEET 4 OF 5
APPROVED DATE	DESIGNED DATE	CHECKED DATE	PROJECT DATE
UNLESS OTHERWISE SPECIFIED, DIMENSIONS ARE IN INCHES AND DECIMALS THEREOF. DIMENSIONS IN PARENTHESES ARE FOR REFERENCE ONLY. TOLERANCES FOR MILLIMETER DIMENSIONS: X.XX, X.X, X.0, X.00, X.000, X.0000. REMOVE ALL SHARP EDGES <math>\le 0.25\text{MM}</math>. ANGLES: 45°, 90°. USE INCH PINS. MAKE FROM:			
COPYRIGHT © 2014 IDEX CORPORATION. NOT TO BE REPRODUCED OR USED TO MAKE OTHER DRAWINGS OR MACHINERY.			

# PARTS LIST – OIL FILTER & STRAINER

### OIL FILTER ASSEMBLY

NOTE 2

ITEM NO.	PART NUMBER	DESCRIPTION	QTY.
1	007-00021-000	ADAPTOR, OIL FILTER, PERMA-COOL PN 6730	1
3	019-3560-00-0	BRACKET, MOUNTING, OIL FILTER	1
4	082-4028-08-0	FITTING, ELBOW, SAE 1-1/16-12 X 1-5/16 JIC	1
5	010-0650-01-0	OIL FILTER FRAME HP6	1
6	097-0190-00-0	LOCKWASHER Z <sub>16</sub> SPLIT ZINC PLATED	2
7	018-1810-25-0	SCREW 7 <sub>16</sub> -14 X 1 ZINC PLATED	2
8	082-3041-01-0	FTG 1-1 <sub>16</sub> -12 O-RING X 1-5/16 JIC	1
9	110-1600-25-0	NUT, HEX 3/8 16, GR8, ZINC PL	2
10	018-1614-25-0	SCREW, HHCS, 3/8-16 X 1-1/2, GR8, ZP	2
11	097-0145-01-0	WASHER, LOCK SPLIT 0.38 ZINC	2

### STRAINER ASSEMBLY

ITEM NO.	PART NUMBER	DESCRIPTION	QTY.
1	088-1446-00-0	BODY, STRAINER	1
2	005-0220-00-0	WASHER, SEALING, STRAINER	1
3	008-0100-00-0	CAP, VALVE, DISCHARGE, 1-1/2"	1
4	082-0501-02-0	NIPPLE, 3/4" NPT BRASS CLOSE	1
5	082-0523-02-0	TEE, 3/4 FNPT	1
6	082-0553-02-0	ELB, 3/4 NPT X 1/2 TUBE CPRSN	2
7	082-0555-02-0	ELB, 3/4 NPT X 3/8 CPRSN L170	1
8	018-1205-44-0	FLA-20 X 5/8" TYPE II CROSS RECESSED RD. HD. SCREW	4
9	101-1340-28-0	PLACARD	1
10	010-0870-00-0	STRAINER BASKET, USED WITHIN 510-0150-00-0	1

**NOTES:**

- APPLY LOCITITE 243 OR EQUAL TO ALL SCREW THREADS.
- APPLY LOCITITE P10 OR EQUAL TO ALL PIPE THREADS.

UNLESS OTHERWISE SPECIFIED DIMENSIONS ARE IN MILLIMETERS. TOLERANCES ARE FOR REFERENCE ONLY. DIMENSIONS FOR MOUNTING TO OTHER DEVICES SHALL BE AS SHOWN.

X .01 X .02 X .03 X .04 X .05 X .06 X .08 X .10 X .12 X .15 X .20 X .25 X .30 X .35 X .40 X .45 X .50 X .55 X .60 X .65 X .70 X .75 X .80 X .85 X .90 X .95 X 1.00 X 1.05 X 1.10 X 1.15 X 1.20 X 1.25 X 1.30 X 1.35 X 1.40 X 1.45 X 1.50 X 1.55 X 1.60 X 1.65 X 1.70 X 1.75 X 1.80 X 1.85 X 1.90 X 1.95 X 2.00

HALE OF IDEX CORPORATION

**GODIVA**

DSD SMARTCAFS ASYS, OIL FILTER & STRAINER

REV: A  
DATE: 10FEB2014  
BY: JRP  
FOR PRODUCTION

REV: D  
DATE: 10FEB2014  
BY: JRP  
FOR PRODUCTION

REV: A  
DATE: 10FEB2014  
BY: JRP  
FOR PRODUCTION

PARTS LIST - COMPRESSOR

**FSG-PL-01306** SHT 1 OF 2

NOTES:  
 1. PARTS 14, 15, 16 AND 17 ARE TO BE USED ON ALL COMPRESSOR ASSEMBLIES.  
 2. PARTS 18, 19, 20 AND 21 ARE TO BE USED ON ALL COMPRESSOR ASSEMBLIES.  
 3. PARTS 22, 23, 24, 25, 26, 27, 28, 29, 30, 31, 32, 33, 34, 35, 36, 37, 38, 39, 40, 41, 42, 43, 44, 45, 46, 47, 48, 49, 50, 51, 52, 53, 54, 55, 56, 57, 58, 59, 60, 61, 62, 63, 64, 65, 66, 67, 68, 69, 70, 71, 72, 73, 74, 75, 76, 77, 78, 79, 80, 81, 82, 83, 84, 85, 86, 87, 88, 89, 90, 91, 92, 93, 94, 95, 96, 97, 98, 99, 100, 101, 102, 103, 104, 105, 106, 107, 108, 109, 110, 111, 112, 113, 114, 115, 116, 117, 118, 119, 120, 121, 122, 123, 124, 125, 126, 127, 128, 129, 130, 131, 132, 133, 134, 135, 136, 137, 138, 139, 140, 141, 142, 143, 144, 145, 146, 147, 148, 149, 150, 151, 152, 153, 154, 155, 156, 157, 158, 159, 160, 161, 162, 163, 164, 165, 166, 167, 168, 169, 170, 171, 172, 173, 174, 175, 176, 177, 178, 179, 180, 181, 182, 183, 184, 185, 186, 187, 188, 189, 190, 191, 192, 193, 194, 195, 196, 197, 198, 199, 200, 201, 202, 203, 204, 205, 206, 207, 208, 209, 210, 211, 212, 213, 214, 215, 216, 217, 218, 219, 220, 221, 222, 223, 224, 225, 226, 227, 228, 229, 230, 231, 232, 233, 234, 235, 236, 237, 238, 239, 240, 241, 242, 243, 244, 245, 246, 247, 248, 249, 250, 251, 252, 253, 254, 255, 256, 257, 258, 259, 260, 261, 262, 263, 264, 265, 266, 267, 268, 269, 270, 271, 272, 273, 274, 275, 276, 277, 278, 279, 280, 281, 282, 283, 284, 285, 286, 287, 288, 289, 290, 291, 292, 293, 294, 295, 296, 297, 298, 299, 300, 301, 302, 303, 304, 305, 306, 307, 308, 309, 310, 311, 312, 313, 314, 315, 316, 317, 318, 319, 320, 321, 322, 323, 324, 325, 326, 327, 328, 329, 330, 331, 332, 333, 334, 335, 336, 337, 338, 339, 340, 341, 342, 343, 344, 345, 346, 347, 348, 349, 350, 351, 352, 353, 354, 355, 356, 357, 358, 359, 360, 361, 362, 363, 364, 365, 366, 367, 368, 369, 370, 371, 372, 373, 374, 375, 376, 377, 378, 379, 380, 381, 382, 383, 384, 385, 386, 387, 388, 389, 390, 391, 392, 393, 394, 395, 396, 397, 398, 399, 400, 401, 402, 403, 404, 405, 406, 407, 408, 409, 410, 411, 412, 413, 414, 415, 416, 417, 418, 419, 420, 421, 422, 423, 424, 425, 426, 427, 428, 429, 430, 431, 432, 433, 434, 435, 436, 437, 438, 439, 440, 441, 442, 443, 444, 445, 446, 447, 448, 449, 450, 451, 452, 453, 454, 455, 456, 457, 458, 459, 460, 461, 462, 463, 464, 465, 466, 467, 468, 469, 470, 471, 472, 473, 474, 475, 476, 477, 478, 479, 480, 481, 482, 483, 484, 485, 486, 487, 488, 489, 490, 491, 492, 493, 494, 495, 496, 497, 498, 499, 500, 501, 502, 503, 504, 505, 506, 507, 508, 509, 510, 511, 512, 513, 514, 515, 516, 517, 518, 519, 520, 521, 522, 523, 524, 525, 526, 527, 528, 529, 530, 531, 532, 533, 534, 535, 536, 537, 538, 539, 540, 541, 542, 543, 544, 545, 546, 547, 548, 549, 550, 551, 552, 553, 554, 555, 556, 557, 558, 559, 560, 561, 562, 563, 564, 565, 566, 567, 568, 569, 570, 571, 572, 573, 574, 575, 576, 577, 578, 579, 580, 581, 582, 583, 584, 585, 586, 587, 588, 589, 590, 591, 592, 593, 594, 595, 596, 597, 598, 599, 600, 601, 602, 603, 604, 605, 606, 607, 608, 609, 610, 611, 612, 613, 614, 615, 616, 617, 618, 619, 620, 621, 622, 623, 624, 625, 626, 627, 628, 629, 630, 631, 632, 633, 634, 635, 636, 637, 638, 639, 640, 641, 642, 643, 644, 645, 646, 647, 648, 649, 650, 651, 652, 653, 654, 655, 656, 657, 658, 659, 660, 661, 662, 663, 664, 665, 666, 667, 668, 669, 670, 671, 672, 673, 674, 675, 676, 677, 678, 679, 680, 681, 682, 683, 684, 685, 686, 687, 688, 689, 690, 691, 692, 693, 694, 695, 696, 697, 698, 699, 700, 701, 702, 703, 704, 705, 706, 707, 708, 709, 710, 711, 712, 713, 714, 715, 716, 717, 718, 719, 720, 721, 722, 723, 724, 725, 726, 727, 728, 729, 730, 731, 732, 733, 734, 735, 736, 737, 738, 739, 740, 741, 742, 743, 744, 745, 746, 747, 748, 749, 750, 751, 752, 753, 754, 755, 756, 757, 758, 759, 760, 761, 762, 763, 764, 765, 766, 767, 768, 769, 770, 771, 772, 773, 774, 775, 776, 777, 778, 779, 780, 781, 782, 783, 784, 785, 786, 787, 788, 789, 790, 791, 792, 793, 794, 795, 796, 797, 798, 799, 800, 801, 802, 803, 804, 805, 806, 807, 808, 809, 810, 811, 812, 813, 814, 815, 816, 817, 818, 819, 820, 821, 822, 823, 824, 825, 826, 827, 828, 829, 830, 831, 832, 833, 834, 835, 836, 837, 838, 839, 840, 841, 842, 843, 844, 845, 846, 847, 848, 849, 850, 851, 852, 853, 854, 855, 856, 857, 858, 859, 860, 861, 862, 863, 864, 865, 866, 867, 868, 869, 870, 871, 872, 873, 874, 875, 876, 877, 878, 879, 880, 881, 882, 883, 884, 885, 886, 887, 888, 889, 890, 891, 892, 893, 894, 895, 896, 897, 898, 899, 900, 901, 902, 903, 904, 905, 906, 907, 908, 909, 910, 911, 912, 913, 914, 915, 916, 917, 918, 919, 920, 921, 922, 923, 924, 925, 926, 927, 928, 929, 930, 931, 932, 933, 934, 935, 936, 937, 938, 939, 940, 941, 942, 943, 944, 945, 946, 947, 948, 949, 950, 951, 952, 953, 954, 955, 956, 957, 958, 959, 960, 961, 962, 963, 964, 965, 966, 967, 968, 969, 970, 971, 972, 973, 974, 975, 976, 977, 978, 979, 980, 981, 982, 983, 984, 985, 986, 987, 988, 989, 990, 991, 992, 993, 994, 995, 996, 997, 998, 999, 1000.

**ORDER OF ASSEMBLY FOR DSD ONLY:**

1. MOUNT (18) COMPRESSOR TO (7) MOUNTING PLATE.
2. MOUNT (19) MOUNTING PLATE TO (1) MOUNTING BASE USING (1) & (2) SHOULDER SCREWS.
3. FINISH ASSEMBLY PRIOR TO MOUNTING TO PUMP.

**NOTE 1**

**501-4140-30-0 / 501-4140-40-0 ASSEMBLY**

ITEM NO.	PART NUMBER	DESCRIPTION	501-4140-30-0 QTY	501-4140-40-0 QTY
1	018-1410-01-0	SCREW, CARRIAGE, 5/16-18 X 1 LG, C4-5, ZP	2	2
2	018-1840-25-0	SCREW, HEX HEAD CAP, 7/16-14 X 4.00 LG	1	1
3	018-2040-65-0	SCREW, SET, 1/2-13 X 4 LG	2	2
4	018-5030-00-0	SCREW, SHOULDER, 1/2 X 2 LG	1	1
5	018-5030-01-0	SCREW, SHOULDER, 2 X 2-1/4 LG	1	N/A
6	019-3450-00-0	SUPPORT, UPPER BELT GUARD	1	1
7	019-3530-00-0	PLATE, COMPRESSOR MOUNTING	1	1
8	019-3540-00-0	COMPRESSOR MOUNTING BASE	1	1
9	019-3571-00-0	MOUNT, ADJUSTABLE, BELT GUARD	1	1
10	062-3059-02-0	FITTING, ELBOW, SWIVEL, 1/8 BSPT X 6 MM COMP	2	2
11	067-0560-01-0	WASHER, SPLIT, 5/16, ZP STEEL	2	2
12	067-2390-00-0	WASHER, SPHERICAL, 7/16	1	1
13	110-1400-02-0	NUT, FINISHED 5/16-18 ZINC	2	2
14	110-2005-02-0	NUT, LOCK, 1/2-13	2	2
15	110-7630-00-0	NUT, COUPLING, 1/2-13	2	2
16	217-3450-00-0	PLUG, M4 SEAL	1	1
17	218-1012-00-0	SCREW, SHCS, M10-1.5 X 25, ZP	4	4
18	501-4140-01-0	COMPRESSOR, TWIN SHAFT, CAFS 2001	1	1
19	538-1470-10-0	ASSEMBLY, VALVE, SMARTCAFS AIR CONTROL	1	1
20	018-5005-599	SCREW, SHOULDER, 1/2 X 2-1/4 LG, SLOT	N/A	1
21	101-2200-00-0	OIL DECAL	1	1

**REVISIONS**

REV	ZONE	DATE	BY	APP	DESCRIPTION
01					
02					
03					
04					
05					
06					
07					
08					
09					
10					
11					
12					
13					
14					
15					
16					
17					
18					
19					
20					
21					
22					
23					
24					
25					
26					
27					
28					
29					
30					
31					
32					
33					
34					
35					
36					
37					
38					
39					
40					
41					
42					
43					
44					
45					
46					
47					
48					
49					
50					
51					
52					
53					
54					
55					
56					
57					
58					
59					
60					
61					
62					
63					
64					
65					
66					
67					
68					
69					
70					
71					
72					
73					
74					
75					
76					
77					
78					
79					
80					
81					
82					
83					
84					
85					
86					
87					
88					
89					
90					
91					
92					
93					
94					
95					
96					
97					
98					
99					
100					

**HALE** GODIVA **SMARTCAFS**

**ASSEMBLY, COMPRESSOR, SMARTCAFS**

REV: 01  
 DATE: 14-MAR-14  
 BY: JDF  
 APP: JDF

REV: 02  
 DATE: 01-NOV-15  
 BY: JDF  
 APP: JDF

REV: 03  
 DATE: 07-NOV-15  
 BY: JDF  
 APP: JDF

REV: 04  
 DATE: 15-MAR-2014  
 BY: DMB  
 APP: JDF

REV: 05  
 DATE: 15-MAR-2014  
 BY: JDF  
 APP: JDF

REV: 06  
 DATE: 15-MAR-2014  
 BY: JDF  
 APP: JDF

REV: 07  
 DATE: 15-MAR-2014  
 BY: JDF  
 APP: JDF

REV: 08  
 DATE: 15-MAR-2014  
 BY: JDF  
 APP: JDF

REV: 09  
 DATE: 15-MAR-2014  
 BY: JDF  
 APP: JDF

REV: 10  
 DATE: 15-MAR-2014  
 BY: JDF  
 APP: JDF

REV: 11  
 DATE: 15-MAR-2014  
 BY: JDF  
 APP: JDF

REV: 12  
 DATE: 15-MAR-2014  
 BY: JDF  
 APP: JDF

REV: 13  
 DATE: 15-MAR-2014  
 BY: JDF  
 APP: JDF

REV: 14  
 DATE: 15-MAR-2014  
 BY: JDF  
 APP: JDF

REV: 15  
 DATE: 15-MAR-2014  
 BY: JDF  
 APP: JDF

REV: 16  
 DATE: 15-MAR-2014  
 BY: JDF  
 APP: JDF

REV: 17  
 DATE: 15-MAR-2014  
 BY: JDF  
 APP: JDF

REV: 18  
 DATE: 15-MAR-2014  
 BY: JDF  
 APP: JDF

REV: 19  
 DATE: 15-MAR-2014  
 BY: JDF  
 APP: JDF

REV: 20  
 DATE: 15-MAR-2014  
 BY: JDF  
 APP: JDF

REV: 21  
 DATE: 15-MAR-2014  
 BY: JDF  
 APP: JDF

REV: 22  
 DATE: 15-MAR-2014  
 BY: JDF  
 APP: JDF

REV: 23  
 DATE: 15-MAR-2014  
 BY: JDF  
 APP: JDF

REV: 24  
 DATE: 15-MAR-2014  
 BY: JDF  
 APP: JDF

REV: 25  
 DATE: 15-MAR-2014  
 BY: JDF  
 APP: JDF

REV: 26  
 DATE: 15-MAR-2014  
 BY: JDF  
 APP: JDF

REV: 27  
 DATE: 15-MAR-2014  
 BY: JDF  
 APP: JDF

REV: 28  
 DATE: 15-MAR-2014  
 BY: JDF  
 APP: JDF

REV: 29  
 DATE: 15-MAR-2014  
 BY: JDF  
 APP: JDF

REV: 30  
 DATE: 15-MAR-2014  
 BY: JDF  
 APP: JDF

REV: 31  
 DATE: 15-MAR-2014  
 BY: JDF  
 APP: JDF

REV: 32  
 DATE: 15-MAR-2014  
 BY: JDF  
 APP: JDF

REV: 33  
 DATE: 15-MAR-2014  
 BY: JDF  
 APP: JDF

REV: 34  
 DATE: 15-MAR-2014  
 BY: JDF  
 APP: JDF

REV: 35  
 DATE: 15-MAR-2014  
 BY: JDF  
 APP: JDF

REV: 36  
 DATE: 15-MAR-2014  
 BY: JDF  
 APP: JDF

REV: 37  
 DATE: 15-MAR-2014  
 BY: JDF  
 APP: JDF

REV: 38  
 DATE: 15-MAR-2014  
 BY: JDF  
 APP: JDF

REV: 39  
 DATE: 15-MAR-2014  
 BY: JDF  
 APP: JDF

REV: 40  
 DATE: 15-MAR-2014  
 BY: JDF  
 APP: JDF

REV: 41  
 DATE: 15-MAR-2014  
 BY: JDF  
 APP: JDF

REV: 42  
 DATE: 15-MAR-2014  
 BY: JDF  
 APP: JDF

REV: 43  
 DATE: 15-MAR-2014  
 BY: JDF  
 APP: JDF

REV: 44  
 DATE: 15-MAR-2014  
 BY: JDF  
 APP: JDF

REV: 45  
 DATE: 15-MAR-2014  
 BY: JDF  
 APP: JDF

REV: 46  
 DATE: 15-MAR-2014  
 BY: JDF  
 APP: JDF

REV: 47  
 DATE: 15-MAR-2014  
 BY: JDF  
 APP: JDF

REV: 48  
 DATE: 15-MAR-2014  
 BY: JDF  
 APP: JDF

REV: 49  
 DATE: 15-MAR-2014  
 BY: JDF  
 APP: JDF

REV: 50  
 DATE: 15-MAR-2014  
 BY: JDF  
 APP: JDF

REV: 51  
 DATE: 15-MAR-2014  
 BY: JDF  
 APP: JDF

REV: 52  
 DATE: 15-MAR-2014  
 BY: JDF  
 APP: JDF

REV: 53  
 DATE: 15-MAR-2014  
 BY: JDF  
 APP: JDF

REV: 54  
 DATE: 15-MAR-2014  
 BY: JDF  
 APP: JDF

REV: 55  
 DATE: 15-MAR-2014

**FSG-PL-01306** SHIT 2 OF 2

NOTES:  
1. MASK FOR PAINTING  
2. ⚠ NEEDS TO BE BENCH SET TO 28-32 PSI.

PROJECTION:

**538-1470-10-0 ASSEMBLY**

ITEM NO.	PART NUMBER	DESCRIPTION	QTY.
1	007-3530-02-0	ADAPTER, AIR INTAKE	1
2	038-1470-03-0	VALVE, AIR CONTROL, 2.5	1
3	038-1690-00-0	VALVE, BLOW DOWN, 250 CFM TANK	1
4	040-3470-00-0	O-RING, .347, BUJANA, 70 DURO	1
5	062-0140-02-0	NIPPLE, 1/4" X 1/8"	2
6	062-4030-03-0	ORIFICE BUSHING, 0.0785"	1
7	067-2390-00-0	WASHER, FLAT, M16, ZP	2
8	200-2690-00-0	LOOM, CORRUGATED, 1/4 ID, 13"	1
9	217-0201-04-0	PLUG, 1/4 NPT HEX HEAD, BRASS	2
10	218-1617-02-0	SCREW, HCS, M16 X 2 X 35, LG. CL. 8.8	2
11	218-1620-02-0	SCREW, HCS, M16 X 2 X 40, LG. CL. 8.8	2
12	242-1060-00-0	CLAMP, HOSE, #52, 1/2 X 3	3
13	340-0940-00-0	HOSE, REDUCER ELBOW, 3/4 X 1/2 X 3	1
14	340-0960-00-0	HOSE, 3 ID X 2-1/4 LG	1
15	604-0690-00-0	TUBE, CLEAR, PFA, 6 X 4mm	16"
16	70141	SPEED CONTROLLER	1
17	062-0214-02-0	BUSHING, HEX, 1/4" MNPT X 1/8" NPT	2
18	062-0020-1702	FITTING, 1/4 MNPT X 6MM TUBE PUSH	2
19	062-3069-02-0	FITTING, ELBOW, SWIVEL, 1/8 BSPT X 6MM COMP.	2
20	038-1690-01-0	V.L.V. 1/8" NEEDLE	1
21	062-00102-706	ADAPTER, 1/8" MNPT X 6MM	1
22	321025	ADPT, 1/8 NPT STREET, BRASS	1
23	038-00071-001	VALVE, POP RELIEF, 1/4 NPT	1
24	106931	TEE 1/4 FPT/1/4 FPT/1/4 FPT SR.	1
25	062-0253-02-0	NIPPLE, HEX, 1/4" NPT	1
26	062-59900-111	TEE, 6MM POH	1

UNLESS OTHERWISE SPECIFIED DIMENSIONS ARE IN MILLIMETERS. TOLERANCE FOR MILLIMETER DIMENSIONS:	  <b>ASSEMBLY, COMPRESSOR, SMARTCAFS</b>
X.X, X.XX, X.XXX, .X, .XX, .XXX SURFACE TEXTURE IN $\mu m Ra$ REMOVE ALL SHARP EDGES, 0.25 MAX	
NOT TO BE COPY REPRODUCED OR USED TO MAKE OTHER DRAWINGS OR MACHINERY	PART NO. FSG-PL-01306 DATE 15 APR 2019 DRAWN BY DMB CHECKED BY K11 DATE 15 APR 2019 DESIGNED BY JSC DATE 27 JUL 2015



# PARTS LIST – SEPARATOR, OIL RESERVOIR

PROJECTION:

## PLATE FSG-PL-01307

NOTES FOR THIS SHEET:  
 REFER TO 108-0050-00-0 DRAWING FOR BASE TANK  
 1. ASSEMBLY ON SHEET 2  
 2. SYSTEM VOLTAGE DETERMINES WHICH SOLENOID IS USED  
 3. USE LOCOTITE PRT OR EQUIV. ON ALL PIPE CONNECTIONS EXCEPT WHERE MIXED THREAD TYPE CONNECTIONS EXIST. IN THIS CASE, USE LOCOTITE 83. DO NOT USE TEFLON TAPE. USE LOCOTITE 83 ON CHECK VALVE DURING INSTALLATION.  
 4. NOT ALL PARTS LISTED IN BOM TABLE ARE USED ON ALL CONFIGURATIONS. REFER TO EACH VIEW FOR CONFIGURATIONS.  
 5. SOLENOID IS DEPENDENT ON CONFIGURATION: 15 AND 16 ARE FOR NON-UV, WHILE 17 AND 18 ARE FOR UV VERSION.  
 6. USE LOCK NUTS. USE WASHERS TO ADJUST HEIGHT OF 019-4050-00-0 AS NEEDED.

**529-00040-005: 12VDC  
529-00040-006: 24VDC**

**SMARTCAFS WITH UV700  
PRESSURE: TRANSDUCER  
VALVE: AIR SENSING**

**529-00040-003: 12VDC  
529-00040-004: 24VDC**

**SMARTCAFS WITH UV700  
PRESSURE: TRANSDUCER  
VALVE: STANDARD AIR**

**529-00040-001: 12VDC  
529-00040-002: 24VDC**

**SMARTCAFS WITHOUT UV700  
PRESSURE: SWITCH  
VALVE: STANDARD AIR**

**529-00040-005: 12VDC  
529-00040-006: 24VDC**

**529-00040-003: 12VDC  
529-00040-004: 24VDC**

**529-00040-001: 12VDC  
529-00040-002: 24VDC**

**529-00040-005: 12VDC  
529-00040-006: 24VDC**

**529-00040-003: 12VDC  
529-00040-004: 24VDC**

**529-00040-001: 12VDC  
529-00040-002: 24VDC**

ITEM NO.	PART NUMBER	DESCRIPTION	QTY
1	108-00051-000	SMARTCAFS SEPARATOR TANK, BASE	1
2	082-0720-02-0	NIPPLE, CLOSE, 1-1/4 NPT	2
3	024-0650-00-0	MUFFLER, 1/8" NPT	4
4	082-0137-02-0	NIPPLE, HEX, 1/8 NPT	1
5	082-0706-02-0	ELBOW, STREET, 1-1/4 NPT	1
6	038-1631-02-0	VALVE, CHECK, AIR INJECT, 1-1/4 BSP	1
7	082-0729-08-0	FITTING, 1-1/4 X 20 JIC	1
8	082-3059-02-0	FITTING, ELBOW, SWIVEL, 1/8 BSPT X 6 MM COMP	3
9	50107-02	AIR VALVE - 1-1/4 SMARTCAFS	1
10	217-0101-15-0	PLUG, SOCKET HEAD, 1/8" NPT	1
11	082-0152-02-0	TEE, F X F X M, 1/8" NPT	1
12	6PNT1840-5	SWITCH, PRESSURE, SMARTCAFS	1
13	604-0690-00-0	TUBE, CLEAR, PFA, 8X4mm	15
14	200-2690-00-0	LOOM, CORRUGATED, 1/4 ID	15
15	038-00043-000	3-WAY SOLENOID VALVE W/CONNECTOR, 24V	3
16	038-00043-010	3-WAY SOLENOID VALVE W/CONNECTOR, 12V	3
17	038-2100-02-0	3 WAY SOL. VLV. MLY. PRP. 24V L170	3
18	038-2101-00-0	3WAY SOLENOID VALVE WITH CONNECTOR, 12VDC	3
19	200-00108	TRANSDUCER PRESS 600PSI	1
20	082-0145-02-0	ELBOW, STREET, 1/8" MNPT X 1/4 FNPT	1
21	200-2592-00-0	AIR SENSING VALVE	1
22	604-0690-00-0	TUBE, CLEAR, PFA, 8X4mm	24
23	200-2690-00-0	LOOM, CORRUGATED, 1/4 ID	24
24	082-00105-702	ADAPTER, 1/8" MNPT X BSPP	3
25	082-00104-708	ADAPTER, 1/8" FNPT X BSPP	2

**529-00040-005: 12VDC  
529-00040-006: 24VDC**

**529-00040-003: 12VDC  
529-00040-004: 24VDC**

**529-00040-001: 12VDC  
529-00040-002: 24VDC**

REV	ZONE	CHANGED FROM	BY	DATE	APPROV
488	K	ADDED ITEM 25 CALLED OUT PORTS ON BYPASS SOLENOIDS	SSJ	08/14/2020	DAB
586	M	ADDED NOTE TO REF. BASE TANK ASY	MAC	03/04/2022	AAS

**529-00040-005: 12VDC  
529-00040-006: 24VDC**

**529-00040-003: 12VDC  
529-00040-004: 24VDC**

**529-00040-001: 12VDC  
529-00040-002: 24VDC**

**529-00040-005: 12VDC  
529-00040-006: 24VDC**

**529-00040-003: 12VDC  
529-00040-004: 24VDC**

**529-00040-001: 12VDC  
529-00040-002: 24VDC**

**529-00040-005: 12VDC  
529-00040-006: 24VDC**

**529-00040-003: 12VDC  
529-00040-004: 24VDC**

**529-00040-001: 12VDC  
529-00040-002: 24VDC**

**529-00040-005: 12VDC  
529-00040-006: 24VDC**

**529-00040-003: 12VDC  
529-00040-004: 24VDC**

**529-00040-001: 12VDC  
529-00040-002: 24VDC**

**529-00040-005: 12VDC  
529-00040-006: 24VDC**

**529-00040-003: 12VDC  
529-00040-004: 24VDC**

**529-00040-001: 12VDC  
529-00040-002: 24VDC**

**529-00040-005: 12VDC  
529-00040-006: 24VDC**

**529-00040-003: 12VDC  
529-00040-004: 24VDC**

**529-00040-001: 12VDC  
529-00040-002: 24VDC**

**529-00040-005: 12VDC  
529-00040-006: 24VDC**

**529-00040-003: 12VDC  
529-00040-004: 24VDC**

**529-00040-001: 12VDC  
529-00040-002: 24VDC**

**529-00040-005: 12VDC  
529-00040-006: 24VDC**

**529-00040-003: 12VDC  
529-00040-004: 24VDC**

**529-00040-001: 12VDC  
529-00040-002: 24VDC**

**529-00040-005: 12VDC  
529-00040-006: 24VDC**

**529-00040-003: 12VDC  
529-00040-004: 24VDC**

**529-00040-001: 12VDC  
529-00040-002: 24VDC**

**529-00040-005: 12VDC  
529-00040-006: 24VDC**

**529-00040-003: 12VDC  
529-00040-004: 24VDC**

**529-00040-001: 12VDC  
529-00040-002: 24VDC**

**529-00040-005: 12VDC  
529-00040-006: 24VDC**

**529-00040-003: 12VDC  
529-00040-004: 24VDC**

**529-00040-001: 12VDC  
529-00040-002: 24VDC**

**529-00040-005: 12VDC  
529-00040-006: 24VDC**

**529-00040-003: 12VDC  
529-00040-004: 24VDC**

**529-00040-001: 12VDC  
529-00040-002: 24VDC**

**529-00040-005: 12VDC  
529-00040-006: 24VDC**

**529-00040-003: 12VDC  
529-00040-004: 24VDC**

**529-00040-001: 12VDC  
529-00040-002: 24VDC**

**529-00040-005: 12VDC  
529-00040-006: 24VDC**

**529-00040-003: 12VDC  
529-00040-004: 24VDC**

**529-00040-001: 12VDC  
529-00040-002: 24VDC**

**529-00040-005: 12VDC  
529-00040-006: 24VDC**

**529-00040-003: 12VDC  
529-00040-004: 24VDC**

**529-00040-001: 12VDC  
529-00040-002: 24VDC**

**529-00040-005: 12VDC  
529-00040-006: 24VDC**

**529-00040-003: 12VDC  
529-00040-004: 24VDC**

**529-00040-001: 12VDC  
529-00040-002: 24VDC**

**529-00040-005: 12VDC  
529-00040-006: 24VDC**

**529-00040-003: 12VDC  
529-00040-004: 24VDC**

**529-00040-001: 12VDC  
529-00040-002: 24VDC**

**529-00040-005: 12VDC  
529-00040-006: 24VDC**

**529-00040-003: 12VDC  
529-00040-004: 24VDC**

**529-00040-001: 12VDC  
529-00040-002: 24VDC**

**529-00040-005: 12VDC  
529-00040-006: 24VDC**

**529-00040-003: 12VDC  
529-00040-004: 24VDC**

**529-00040-001: 12VDC  
529-00040-002: 24VDC**

**529-00040-005: 12VDC  
529-00040-006: 24VDC**

**529-00040-003: 12VDC  
529-00040-004: 24VDC**

**529-00040-001: 12VDC  
529-00040-002: 24VDC**

**529-00040-005: 12VDC  
529-00040-006: 24VDC**

**529-00040-003: 12VDC  
529-00040-004: 24VDC**

# PLATE FSG-PL-01307

P/N: 108-00051-000

- NOTES FOR THIS SHEET:  
 1. THE LISTED PARTS ARE EQUIV ON ALL PIPE CONNECTIONS EXCEPT WHERE MIXED THREAD TYPE CONNECTIONS EXIST. IN THIS CASE, USE LOCITITE 243. DO NOT USE TEFLON TAPE.  
 2. USE CAUTION WHEN APPLYING DECALS. WHEN APPLYING OIL LEVEL MIN/MAX DECAL, POSITION THE MIN OIL LEVEL IN LINE WITH THE TOP OF THE OIL LEVEL TUBE COMPRESSION NUT.

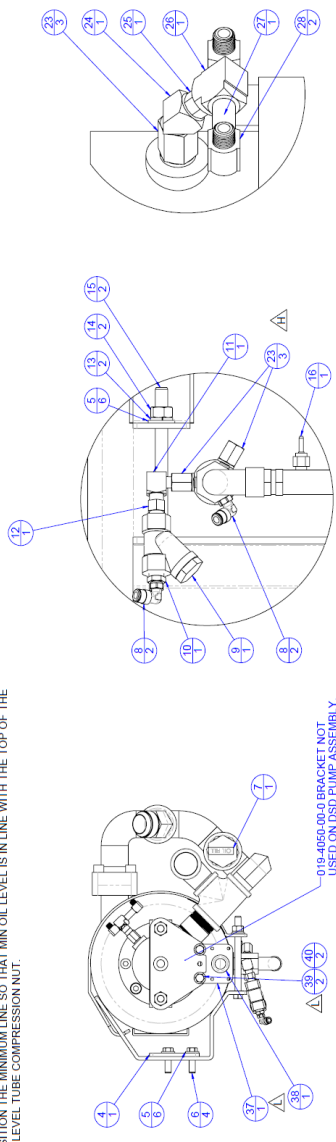

**DETAIL A**  
SCALE 1:2

**DETAIL B**  
SCALE 1:1

038-00109-000 RELIEF VALVE ASSEMBLY REFER TO FSG-PL-01308 FOR INSTRUCTIONS.  
 019-4050-00-0 BRACKET NOT USED ON DSD PUMP ASSEMBLY.

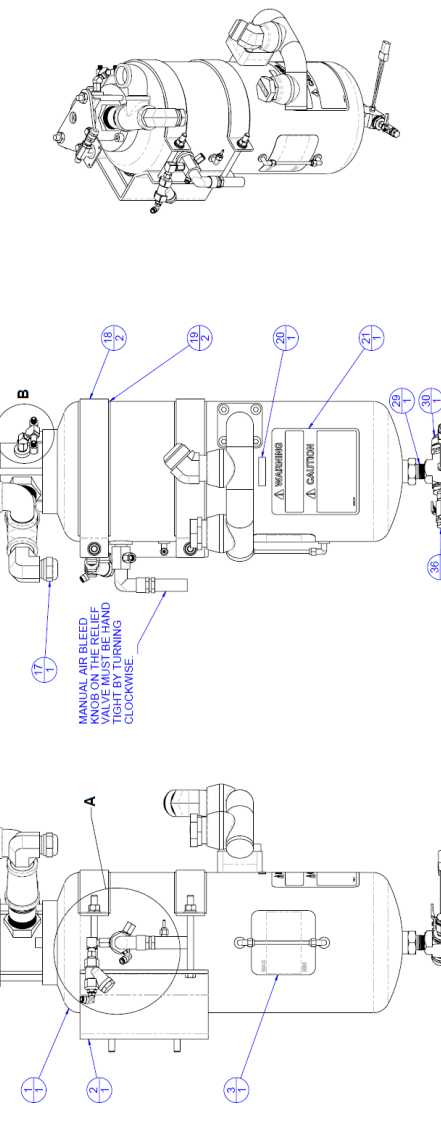

MAKING AIR LEAK WORK ON THE RELIEF VALVE MUST BE HAND TIGHT BY TURNING CLOCKWISE.

ITEM NO.	PART NUMBER	DESCRIPTION	QTY.
1	108-0630-00-0	TANK SEPARATOR, OIL RESERVOIR ASY	1
2	019-3430-00-0	BRACKET, SEPARATOR TANK MTO.	1
3	101-2360-00-0	DECAL, OIL LEVEL, CAFS SEP. TANK	1
4	019-3700-00-0	PLATE, DOUBLER, SEPARATOR TANK	1
5	007-0250-00-0	ZEYC-308 WASHER	6
6	018-1814-25-0	SCRW 7/16-14L1.5GR8 ZINC PL	4
7	101-0150-00-0	DECAL, OIL FILL	1
8	082-3059-02-0	FITTING, ELBOW, SWIVEL, 1/8 BSPT X 6MM COMP	2
9	010-0710-00-0	STRAINER, 1/4" WYE	1
10	082-0214-02-0	BUSHING, HEX, 1/4" MNPT X 1/8" NPT	1
11	082-0145-02-0	ELBOW, STREET, 1/8" MNPT X 1/4 FNPT	1
12	082-0253-02-0	NIPPLE, HEX, 1/4" NPT	1
13	097-0190-00-0	WASHER, SPLIT LOCK, 7/16	2
14	110-1800-02-0	NUT, 7/16-14, STEEL, ZP	2
15	018-1854-02-0	SCREW, HEX HEAD, 7/16-14 X 5-1/2, ZP	2
16	082-4030-03-0	ORIFICE BUSHING, 0.0785"	1
17	082-0801-06-0	CAP, -16 JIC	1
18	242-1050-00-0	STRAP, MTO, SEPARATOR TANK	2
19	046-1730-00-0	RUBBER, EPDM, 1/32" THK X 2" WIDE	2
20	101-2040-00-0	LABEL, METRIC SUBASSEMBLY	1
21	101-1410-01-0	DECAL, RESERVOIR WARNING	1
22	019-4050-00-0	BRACKET, MTO, SEPARATOR TANK, AIR CYLINDER	1
23	082-00104-708	ADAPTER, 1/8" FNPT X BSPP	3
24	082-00100-002	1/4" NPT X 1/8" FNPT, 45 ELBOW, BRASS	1
25	082-0137-02-0	NIPPLE, HEX, 1/8" NPT	1
26	082-0152-02-0	TEE, F X F X M, 1/8" NPT	1
27	082-0125-02-0	NIPPLE, 1/8" NPT X 1-1/2 LG	1
28	321025	ADPT, 1/8 NPT STREET, BRASS	2
29	082-00503-706	NIPPLE, 3/4" BSPT X NPT, SST	1
30	082-0542-08-0	FIT - 3/4" MNPT X -16 JIC L170	1
31	200-1161-00-0	TEMPERATURE SENSOR-10KP	1
32	082-0523-02-9	TEE, 3/4" FNPT W/1/8" FNPT	1
33	082-0513-02-0	REDUCER BSNG 3/4 MPT/1/4 FTT B	1
34	082-0253-02-0	NIPPLE, 1/4" NPT HEX	1
35	038-1130-00-0	VALVE BALL, 1/4" NPT FEMALE	1
36	217-0201-09-0	PLUG, 1/4" NPT HEX HD BRASS	1
37	019-0564-00-0	BRACKET, RELIEF VALVE, CAFS	1
38	048-00052-00-0	GROMMET, 1.375 IN O.D.	1
39	018-1806-25-0	SCREW, 3/8-16 X .75 ZINC PLATED	2
40	087-0170-00-0	WASHER, FLAT 0.38 SAE ZINC	2

**HALE** SMARTCAFS  
 OIL SEPARATOR TANK, BASE

HALE  
 SMARTCAFS

HALE  
 SMARTCAFS

**GODIVA**  
 SMARTCAFS

HALE  
 SMARTCAFS

HALE  
 SMARTCAFS

REV	DATE	BY	CHKD
M			

DIMENSIONS SHOWN ARE IN MILLIMETERS UNLESS OTHERWISE SPECIFIED.  
 DIMENSIONS ARE IN MILLIMETERS UNLESS OTHERWISE SPECIFIED.  
 X 1/4" = 25.4  
 X 1/2" = 50.8  
 X 3/4" = 76.2  
 X 1" = 101.6  
 ANGLES: 45°, 90°, 120°  
 REMOVE ALL SHARP EDGES, 0.25 MAX

NOT TO BE REPRODUCED OR USED TO MAKE OTHER DRAWINGS OR PARTS WITHOUT THE WRITTEN PERMISSION OF HALE PRODUCTS, INC.

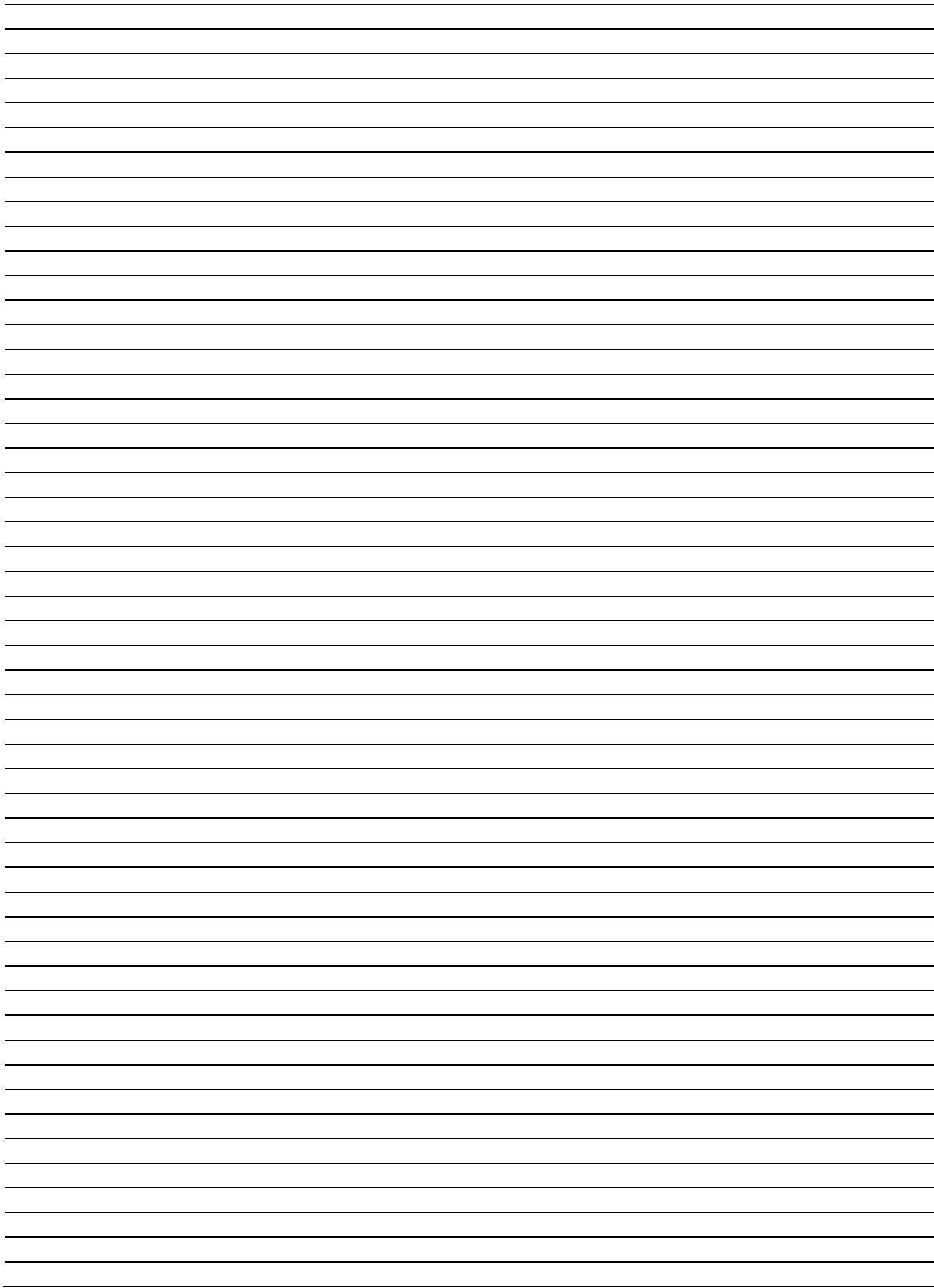

**QUICK REFERENCE GUIDE/TROUBLESHOOTING**

**AIR INJECTION/CONTROL**

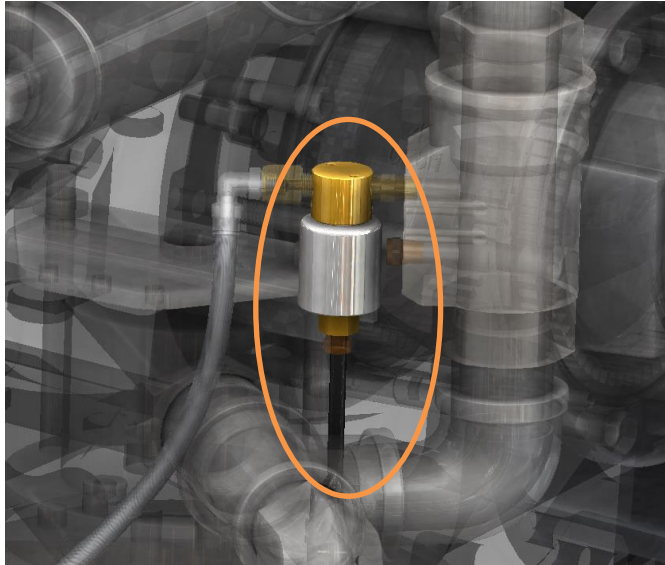

<b>PART NUMBER</b>	<b>12V: 038-00043-010</b> <b>24V: 038-00043-000</b>
<b>DESCRIPTION</b>	Air Inject Solenoid
<b>OPERATION</b>	Controls the air supply to the air inject valve. When the air is supplied to the air valve it allows air to be injected into the system.
<b>POSSIBLE FAULT</b>	<ul style="list-style-type: none"> <li>• No Air Injection               <ul style="list-style-type: none"> <li>○ No power being supplied to solenoid.</li> <li>○ Solenoid is clogged.</li> <li>○ Solenoid has failed.</li> </ul> </li> </ul>

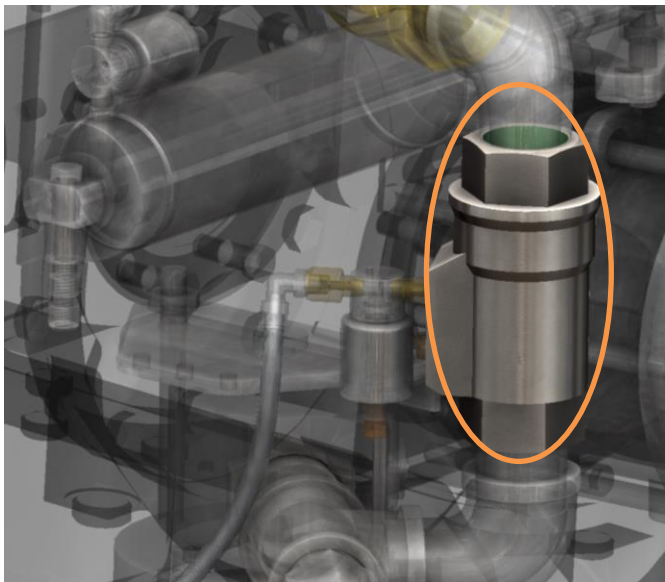

<b>PART NUMBER</b>	<b>59107-02</b>
<b>DESCRIPTION</b>	Air Inject Valve
<b>OPERATION</b>	Controls the air injection into the water/foam manifold. When this receives air from the air solenoid it has a plunger that lifts from its seat to allow air to pass through.
<b>POSSIBLE FAULT</b>	<ul style="list-style-type: none"> <li>• Not opening               <ul style="list-style-type: none"> <li>○ No air from solenoid.</li> <li>○ Air port from solenoid is clogged.</li> </ul> </li> <li>• Not closing               <ul style="list-style-type: none"> <li>○ Valve seat is dirty.</li> <li>○ Valve seal has failed.</li> </ul> </li> </ul>

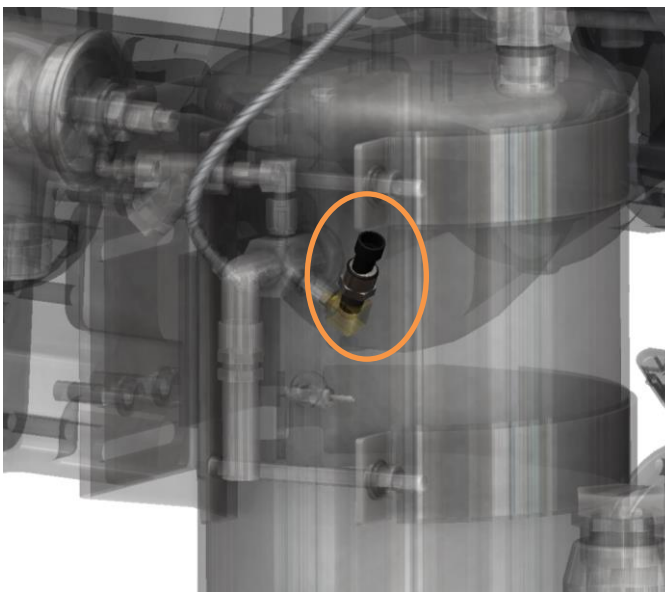

<b>PART NUMBER</b>	<b>200-00108</b>
<b>DESCRIPTION</b>	Air Pressure Detect Transducer
<b>OPERATION</b>	This transducer reads air pressure. Once this transducer senses 5 psi it disables the clutch from engaging. This also controls the interlock for air injection. It also provides the air pressure readout on the display.
<b>POSSIBLE FAULT</b>	<ul style="list-style-type: none"> <li>• Air is not injecting               <ul style="list-style-type: none"> <li>○ Transducer not detecting air pressure.</li> <li>○ No power to transducer.</li> <li>○ Transducer has failed.</li> </ul> </li> <li>• Clutch is not engaging               <ul style="list-style-type: none"> <li>○ Air pressure &gt; 5 psi detected.</li> <li>○ No power to transducer.</li> <li>○ Transducer has failed.</li> </ul> </li> </ul>

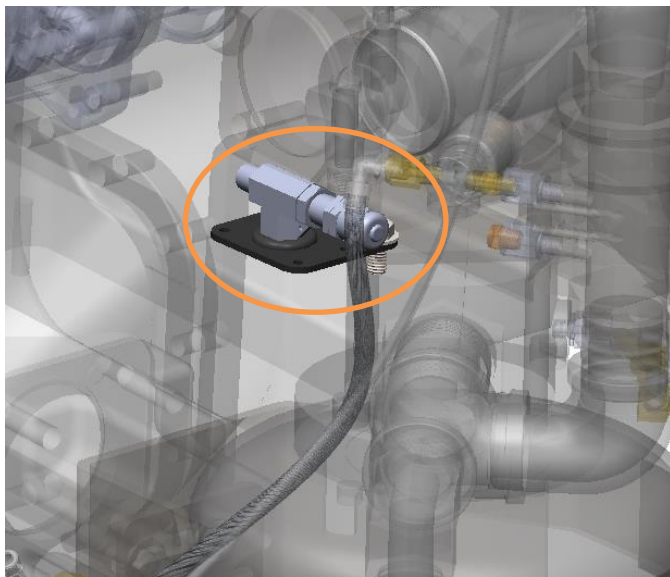

<b>PART NUMBER</b>	<b>038-00109-000</b>
<b>DESCRIPTION</b>	Air Pressure Limiter
<b>OPERATION</b>	This relief valve is to be set at 170-175 PSI. It limits the max air pressure the system can produce.
<b>POSSIBLE FAULT</b>	<ul style="list-style-type: none"> <li>• Air pressure not sufficient               <ul style="list-style-type: none"> <li>○ Pressure limiter limiting the max air pressure allowed.</li> </ul> </li> <li>• Air pressure over 175 PSI               <ul style="list-style-type: none"> <li>○ Relief Valve not set to adequate range</li> </ul> </li> </ul>

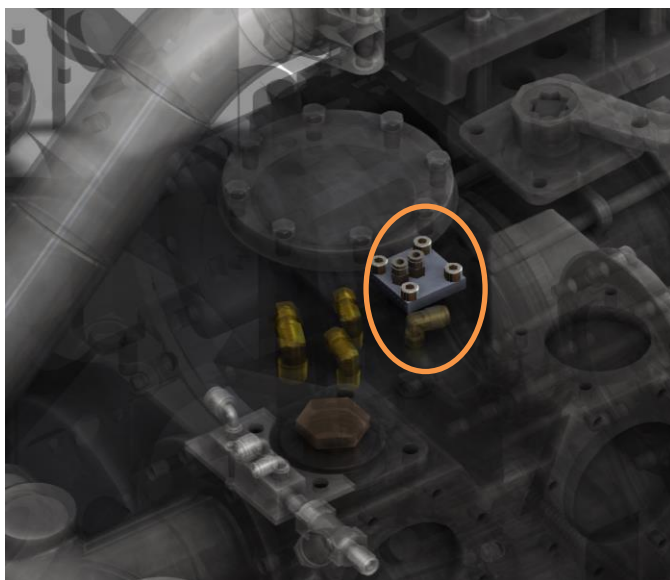

<b>PART NUMBER</b>	<b>61215</b>
<b>DESCRIPTION</b>	Air Balance Valve
<b>OPERATION</b>	Controls the air intake valve for the compressor in order to match the air to the water pressure. Air is injected from the outside port onto a plunger which is raised and lowered by the water pressure from the other side to choke and open the air intake for the compressor.
<b>POSSIBLE FAULT</b>	<ul style="list-style-type: none"> <li>• Air is not matching               <ul style="list-style-type: none"> <li>○ O-ring needs to be greased</li> <li>○ Water inlet has been crushed preventing the plunger from moving properly.</li> </ul> </li> </ul> <p>See <b>“CAFS - Setting the Air Balance control Valves”</b> on page 90.</p>

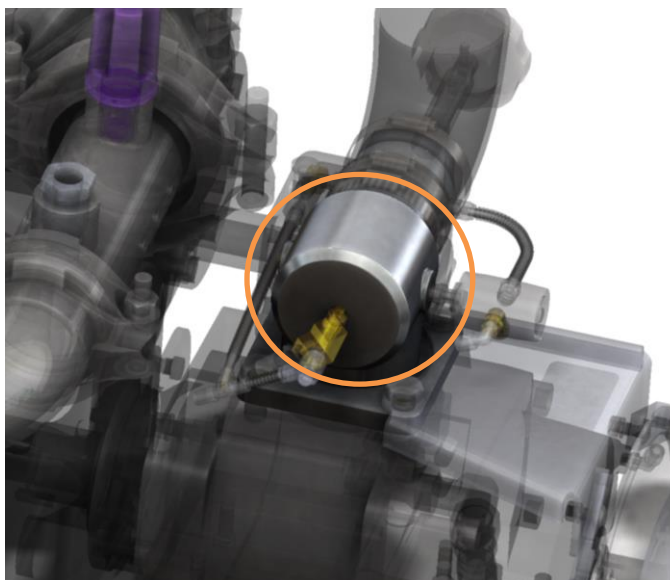

<b>PART NUMBER</b>	<b>038-1470-03-0</b>
<b>DESCRIPTION</b>	Air Intake Valve
<b>OPERATION</b>	Controls the amount of air going into the compressor. This in turn controls the amount of air being injected into the system. The farther open the plunger the more air being injected. The plunger is balanced
<b>POSSIBLE FAULT</b>	<ul style="list-style-type: none"> <li>• No air injection               <ul style="list-style-type: none"> <li>○ Too much air pressure from the control side of the air intake valve from the air balance valve</li> </ul> </li> <li>• Pressure match isn't smooth               <ul style="list-style-type: none"> <li>○ Plunger is sticking</li> </ul> </li> <li>• Pressure isn't matching               <ul style="list-style-type: none"> <li>○ See instructions on page 90.</li> </ul> </li> <li>• Air leaks               <ul style="list-style-type: none"> <li>○ O-ring/Seal is bad</li> <li>○ Bolts to compressor are loose.</li> </ul> </li> </ul>

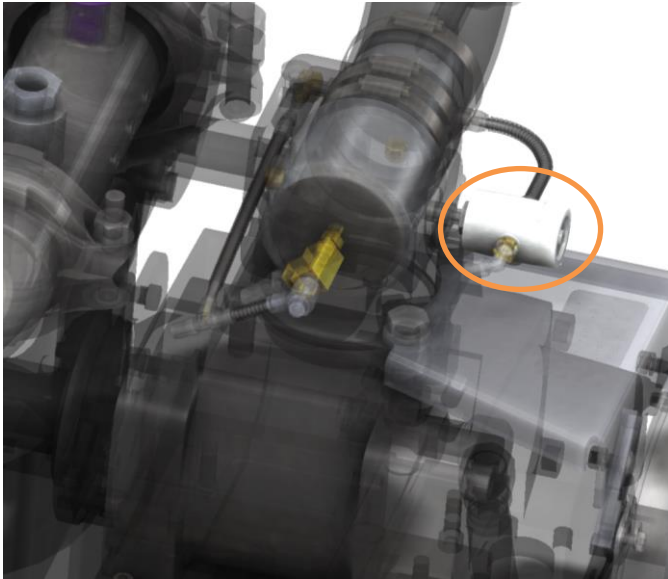

<b>PART NUMBER</b>	<b>038-1560-00-0</b>
<b>DESCRIPTION</b>	Blow Down Valve
<b>OPERATION</b>	Releases built up pressure in air system. Air pressure is supplied from the oil separator and the air intake. If they don't match the valve opens connection from the oil separator to atmosphere
<b>POSSIBLE FAULT</b>	<ul style="list-style-type: none"> <li>• Air leaks               <ul style="list-style-type: none"> <li>○ Valve is bad</li> <li>○ Fittings are loose</li> </ul> </li> </ul>



<b>PART NUMBER</b>	<b>038-00071-001</b>
<b>DESCRIPTION</b>	Air Relief Valve
<b>OPERATION</b>	This valve relieves pressure from the control side of the air intake valve. Any pressure above the required pressure to close the air intake valve will be released. This improves the tracking speed for the pressure match, especially when reducing water pressure.
<b>POSSIBLE FAULT</b>	<ul style="list-style-type: none"> <li>• Pressure isn't matching               <ul style="list-style-type: none"> <li>○ Relief pressure is set too low. Tighten to increase relief pressure.</li> </ul> </li> <li>• Air leaks               <ul style="list-style-type: none"> <li>○ O-ring/Seal is bad</li> </ul> </li> </ul>

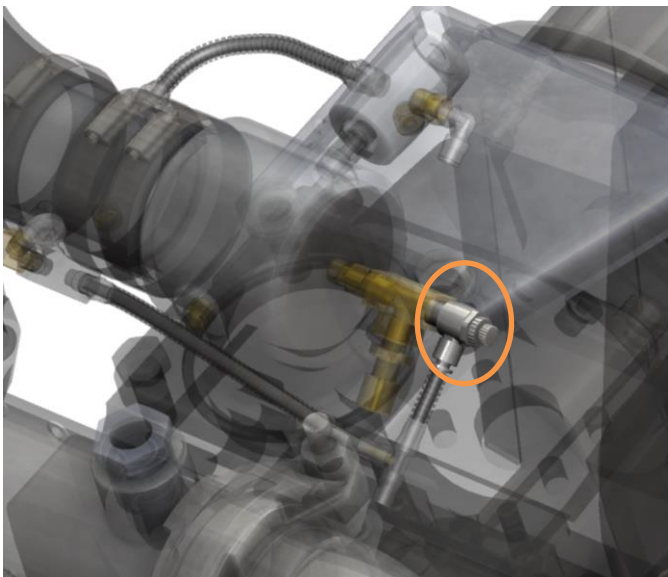

<b>PART NUMBER</b>	<b>70141</b>
<b>DESCRIPTION</b>	Air Intake Control Needle Valve
<b>OPERATION</b>	This valve controls the amount of air pressure limiting the air intake. The larger the air pressure the lower the air flow into the compressor. It also dampens the response of the air intake plunger.
<b>POSSIBLE FAULT</b>	<ul style="list-style-type: none"> <li>• Air/Water tracking is not steady               <ul style="list-style-type: none"> <li>○ Needle valve is open too far.</li> </ul> </li> <li>• Air/Water tracking is too slow when changing water pressure               <ul style="list-style-type: none"> <li>○ Needle valve is closed too far.</li> </ul> </li> </ul> <p>See instructions on page <b>90</b>.</p>

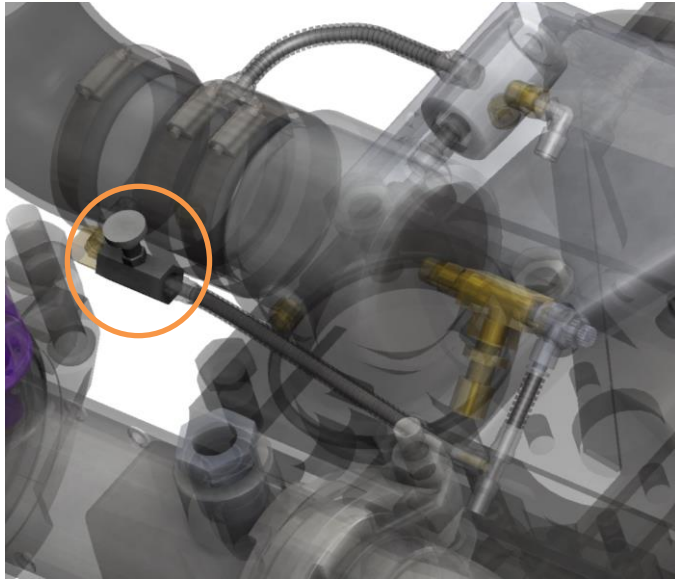

<b>PART NUMBER</b>	<b>038-1680-01-0</b>
<b>DESCRIPTION</b>	Air Intake Inlet Needle Valve
<b>OPERATION</b>	This valve controls the amount of air pressure dumping to atmosphere. The more air dumping the farther the air intake plunger opens.
<b>POSSIBLE FAULT</b>	<ul style="list-style-type: none"> <li>• Air flow for wet is too great                             <ul style="list-style-type: none"> <li>○ Needle valve is open too far.</li> </ul> </li> <li>• Air/Water not tracking                             <ul style="list-style-type: none"> <li>○ Needle valve is closed too far.</li> <li>○ Needle valve is clogged.</li> </ul> </li> <li>• Air/Water is not dry enough                             <ul style="list-style-type: none"> <li>○ Needle valve is closed too far.</li> </ul> </li> </ul> <p>See instructions on page <b>90</b>.</p>

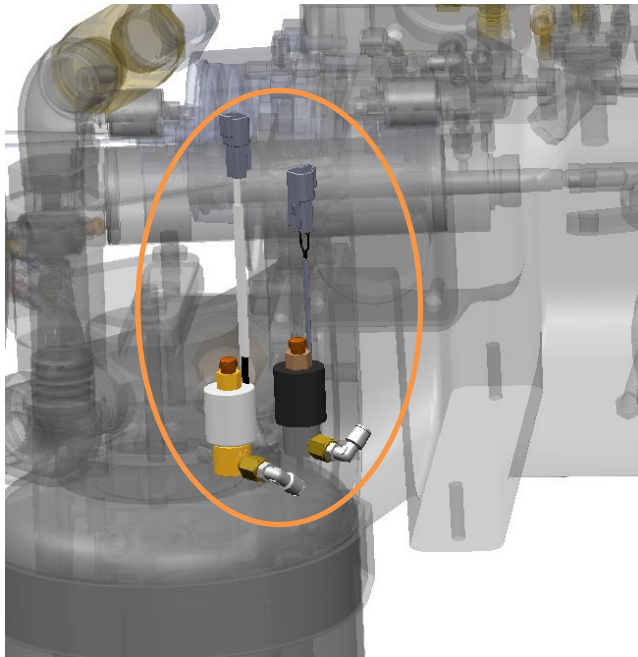

<b>PART NUMBER</b>	<b>12V: 038-2101-00-0</b> <b>24V: 038-2100-02-0</b>
<b>DESCRIPTION</b>	Air Pressure Bypass Solenoids
<b>OPERATION</b>	These solenoids provide quick air pressure relieve for system upon shutoff of air injection signal.
<b>POSSIBLE FAULT</b>	<ul style="list-style-type: none"> <li>• System air exhaust noise upon quick RPM drop                             <ul style="list-style-type: none"> <li>○ Solenoids are not activating</li> <li>○ Solenoids activating but lines could be clogged</li> </ul> </li> </ul>

**COMPRESSOR OPERATION**

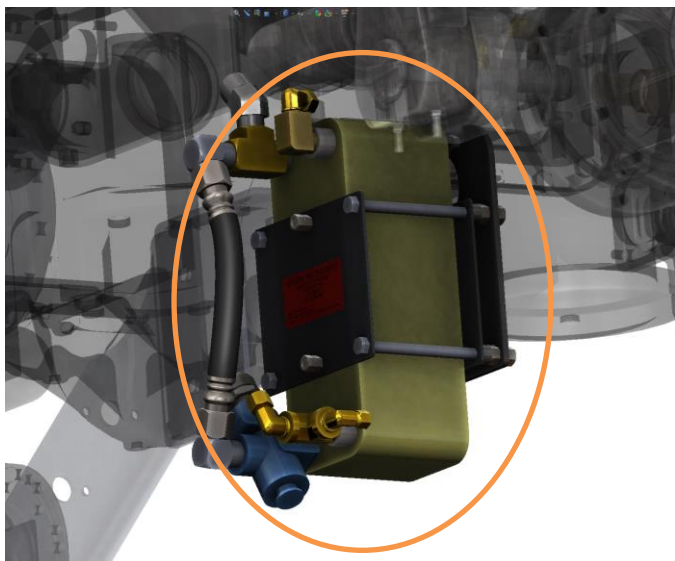

<b>PART NUMBER</b>	<b>108-0641-00-0</b>
<b>DESCRIPTION</b>	Heat Exchanger
<b>OPERATION</b>	Plate style heat exchanger cools the oil from the oil separator for the compressor with discharge water from the pump. Thermostatic Valve <b>038-1390-00-0</b> opens at 150°F (65°C) to allow the oil to run through the heat exchanger otherwise it bypasses the heat exchanger.
<b>POSSIBLE FAULT</b>	<ul style="list-style-type: none"> <li>• Not opening                             <ul style="list-style-type: none"> <li>○ No air from solenoid.</li> <li>○ Air port from solenoid is clogged.</li> </ul> </li> </ul>

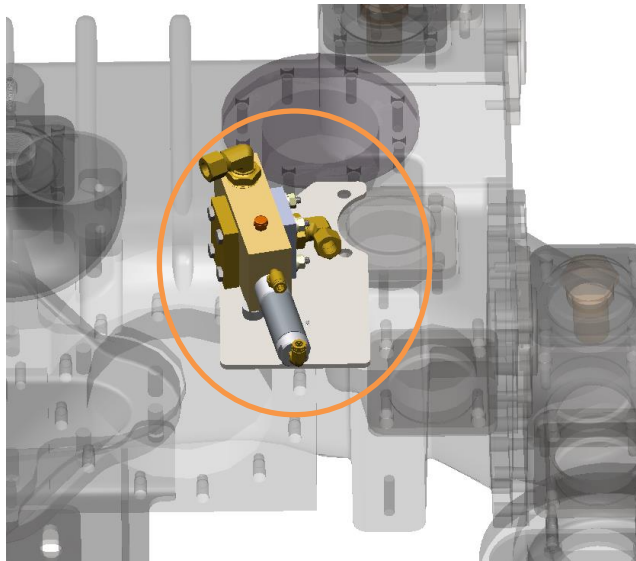

<b>PART NUMBER</b>	<b>538-00107-000</b>
<b>DESCRIPTION</b>	Cooler Valve
<b>OPERATION</b>	Cooling water from the heat exchanger designed to cool the compressor is plumbed to the tank. When not running CAFS (i.e. drafting), the tank can overflow. This solenoid/valve assembly is designed to be flowing when the clutch solenoid is engaged.
<b>POSSIBLE FAULT</b>	<ul style="list-style-type: none"> <li>• Not opening               <ul style="list-style-type: none"> <li>○ No air to 4-way valve.</li> <li>○ Air ports clogged.</li> <li>○ No signal from clutch solenoid.</li> </ul> </li> </ul>

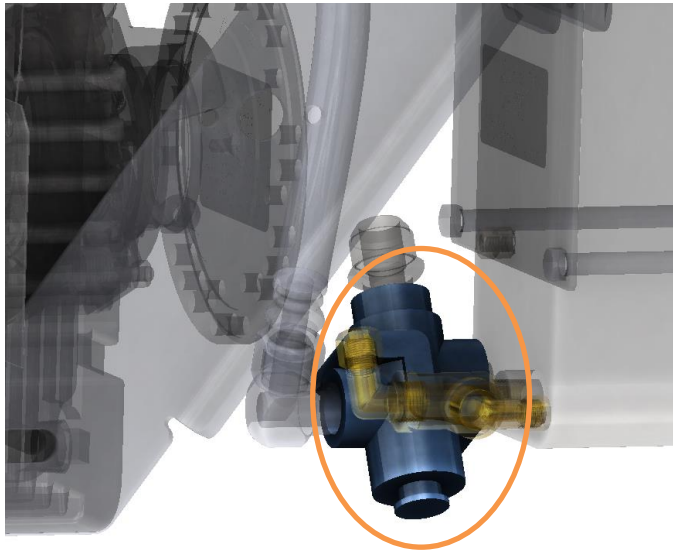

<b>PART NUMBER</b>	<b>038-1390-00-0</b>
<b>DESCRIPTION</b>	Thermostatic Oil Bypass Valve
<b>OPERATION</b>	Opens at 150°F (65°C) [fully opening at 170°F (76°C)] to allow the oil to run through the heat exchanger otherwise it bypasses the heat exchanger.
<b>POSSIBLE FAULT</b>	<ul style="list-style-type: none"> <li>• Compressor is overheating               <ul style="list-style-type: none"> <li>○ Not fully opening.</li> <li>○ Oil temperature is above max operating temperature.</li> </ul> </li> </ul>

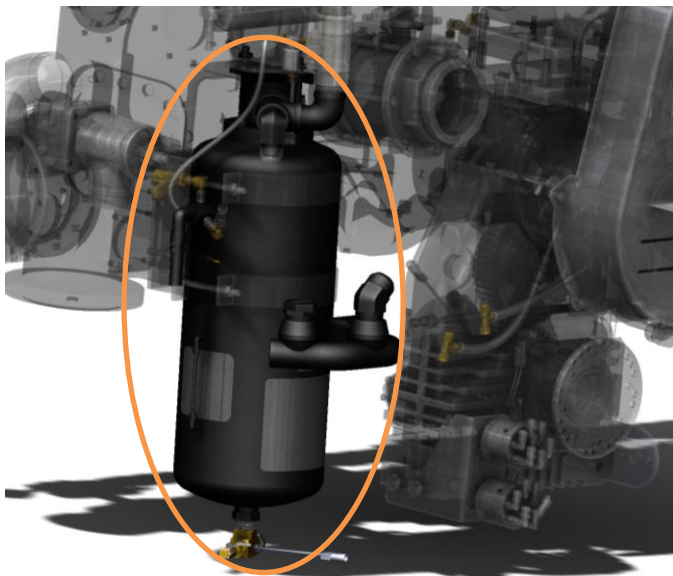

<b>PART NUMBER</b>	<b>108-0630-00-0</b>
<b>DESCRIPTION</b>	Oil Separator
<b>OPERATION</b>	Separates the air and oil through a series of chambers internally and any condensation/water, which can be drained from the bottom ball valve. The side “arm” is for replacing oil. The top port with the air valve is for discharging air to the pump or auxiliary port. The hex on the side supplies air to the control system for the compressor.
<b>POSSIBLE FAULT</b>	<ul style="list-style-type: none"> <li>• Compressor is overheating               <ul style="list-style-type: none"> <li>○ Oil is not at proper level.</li> <li>○ Oil not being cooled by Heat Exchanger.</li> <li>○ Coolant Valve not opening.</li> </ul> </li> <li>• Air injection/Pressure match               <ul style="list-style-type: none"> <li>○ Hex port on side is leaking</li> <li>○ Brass orifice is missing from scavenge line.</li> </ul> </li> </ul>



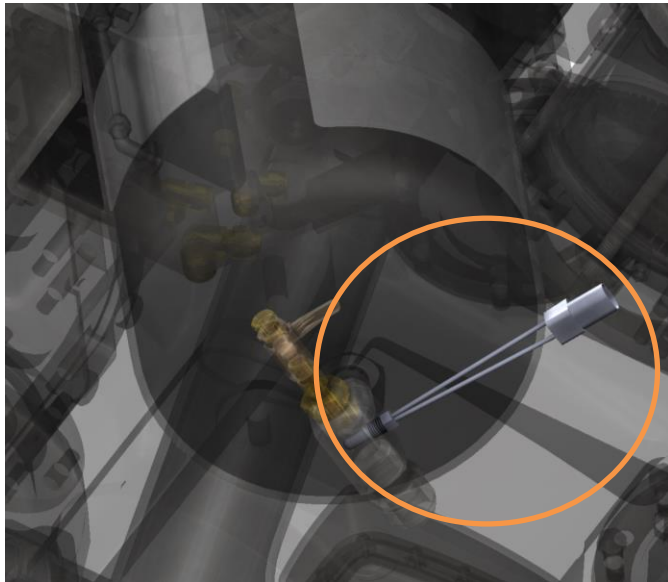

<b>PART NUMBER</b>	<b>200-1161-00-0</b>
<b>DESCRIPTION</b>	Oil Temperature Sensor
<b>OPERATION</b>	Temperature sensor enables/disables the compressor interlock. If temperature goes outside of operating range or if system loses signal from this sensor then the clutch will be disabled.
<b>POSSIBLE FAULT</b>	<ul style="list-style-type: none"> <li>• Clutch is not engaging               <ul style="list-style-type: none"> <li>○ No signal from this sensor.</li> <li>○ Oil temperature is outside of operating range.</li> </ul> </li> </ul>

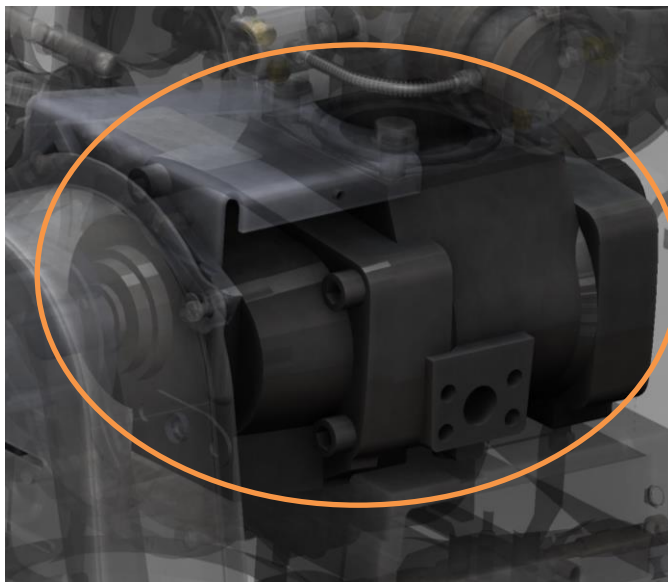

<b>PART NUMBER</b>	<b>501-4140-01-0</b>
<b>DESCRIPTION</b>	Compressor
<b>OPERATION</b>	Oil lubricated twin screw compressor is driven by gearbox by a herringbone drive belt that is enabled by a pneumatic clutch. Compressor is water cooled by plate heat exchanger. Air is supplied and controlled by the air intake valve.
<b>POSSIBLE FAULT</b>	<ul style="list-style-type: none"> <li>• Clutch is not engaging               <ul style="list-style-type: none"> <li>○ See clutch section.</li> </ul> </li> <li>• Overheating               <ul style="list-style-type: none"> <li>○ Belt is not a correct tension</li> <li>○ Heat exchanger not functioning</li> <li>○ Oil is not at correct level</li> </ul> </li> <li>• No Air injection               <ul style="list-style-type: none"> <li>○ Air Intake Valve isn't opening</li> <li>○ Air Injection Valve isn't opening</li> </ul> </li> </ul>

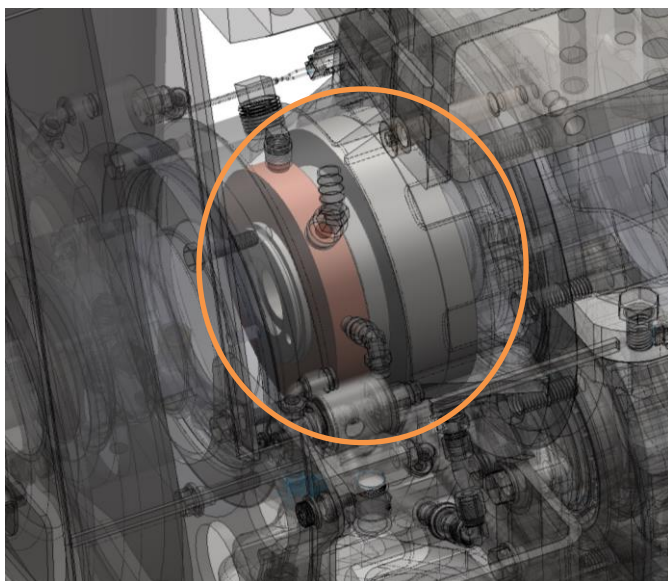

<b>PART NUMBER</b>	<b>505-0260-01-0</b>
<b>DESCRIPTION</b>	Clutch
<b>OPERATION</b>	Pneumatic Clutch that can be set through the UV display to be engaged upon start up or only when CAFS is needed. It operates from truck air and is enabled by a solenoid. The engagement timing is controlled by a needle valve attached to the engagement solenoid.
<b>POSSIBLE FAULT</b>	<ul style="list-style-type: none"> <li>• Clutch is not engaging               <ul style="list-style-type: none"> <li>○ Clutch solenoid has failed</li> <li>○ Inadequate air supply</li> <li>○ Needle valve not set correctly.</li> <li>○ Interlocks are enabled.</li> </ul> </li> <li>• Overheating               <ul style="list-style-type: none"> <li>○ Oil is at incorrect level</li> <li>○ Plates are damaged</li> <li>○ Belt is installed crooked</li> <li>○ Belt is not at correct tension.</li> </ul> </li> </ul>



<b>PART NUMBER</b>	<b>12V: 538-1910-10-0</b> <b>24V: 538-1910-00-0</b>
<b>DESCRIPTION</b>	Clutch Enable Solenoid
<b>OPERATION</b>	The clutch solenoid is normally closed. When all of the interlock conditions are met the solenoid opens and allows air to engage the clutch.
<b>POSSIBLE FAULT</b>	<ul style="list-style-type: none"> <li>• Clutch is not engaging               <ul style="list-style-type: none"> <li>○ Clutch solenoid has failed</li> <li>○ Solenoid not receiving signal</li> <li>○ Inadequate air supply</li> <li>○ Interlocks are enabled.</li> <li>○ Incorrect Solenoid is installed (Voltage or Normally Open)</li> </ul> </li> </ul>

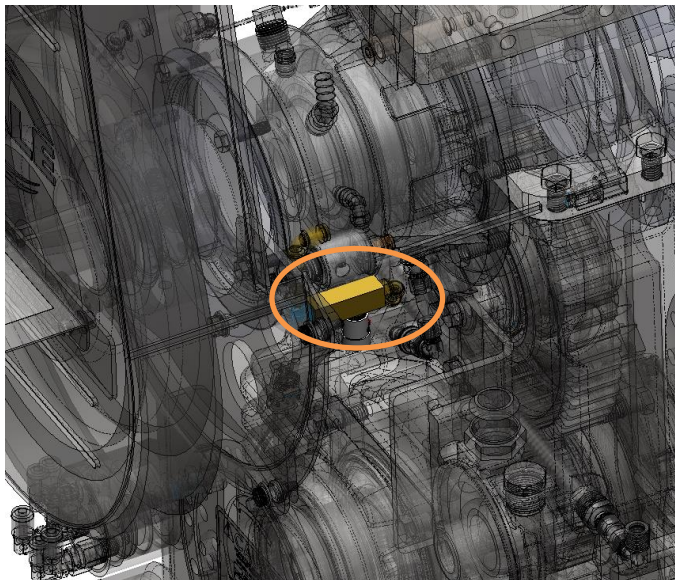

<b>PART NUMBER</b>	<b>038-2030-00-0</b>
<b>DESCRIPTION</b>	Clutch Needle Valve
<b>OPERATION</b>	Clutch needle valve controls the engagement speed of the clutch by controlling the amount of air going to the clutch. Closing the needle valve slows engagement, while opening the needle valve speeds engagement.
<b>POSSIBLE FAULT</b>	<ul style="list-style-type: none"> <li>• Clutch is not engaging               <ul style="list-style-type: none"> <li>○ Clutch solenoid has failed</li> <li>○ Inadequate air supply</li> <li>○ Needle valve not set correctly.</li> <li>○ Interlocks are enabled.</li> </ul> </li> </ul> <p>See “CAFS – Hot Shift Clutch Engagement” on page 92.</p>

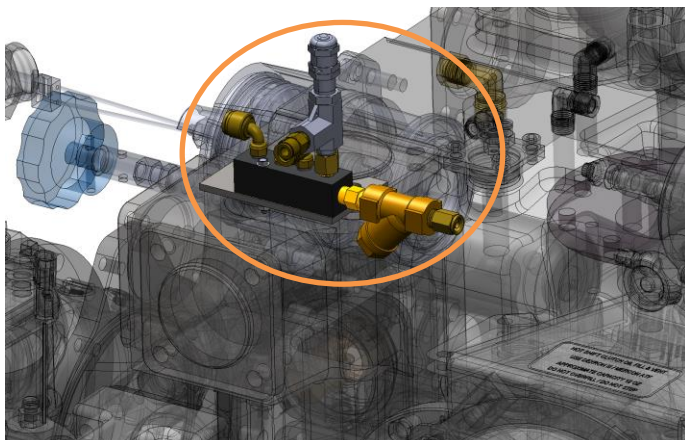

<b>PART NUMBER</b>	<b>178-1050-10-0</b>
<b>DESCRIPTION</b>	Truck Air Manifold
<b>OPERATION</b>	<p>This air manifold is used as an inlet from the truck air. It supplies air to the Master Drain, Tank-to-Pump, and clutch.</p> <p>The pressure limiter is in line for the clutch and set to restrict the max air pressure going to clutch to 100 PSI.</p>
<b>POSSIBLE FAULT</b>	<p>Problems with Master Drain, Tank-to-Pump, and Clutch can be from:</p> <ul style="list-style-type: none"> <li>• Dirty Strainer</li> <li>• Leaks in Manifold</li> <li>• No air from truck</li> </ul> <p>Clutch breather spitting oil can be from:</p> <ul style="list-style-type: none"> <li>• Pressure limiter not set correctly</li> </ul>

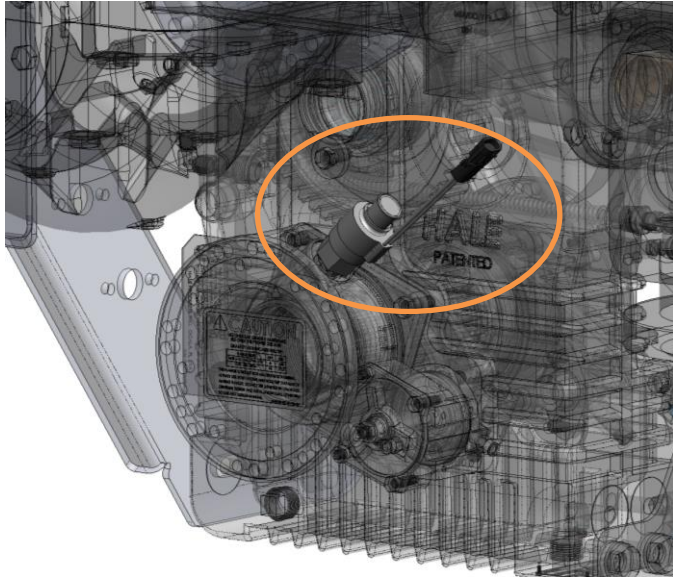

<b>PART NUMBER</b>	<b>200-2610-00-0</b>
<b>DESCRIPTION</b>	Tachometer
<b>OPERATION</b>	Tachometer reads the rotation of the drive shaft. It reports to the UV SmartCAFS display in order to meet interlock requirements for the clutch enable.
<b>POSSIBLE FAULT</b>	<ul style="list-style-type: none"> <li>• Clutch is not engaging             <ul style="list-style-type: none"> <li>○ Engine speed is too high</li> <li>○ Tachometer has failed</li> <li>○ Harness is damaged.</li> </ul> </li> </ul>

**CAFS OPERATION**

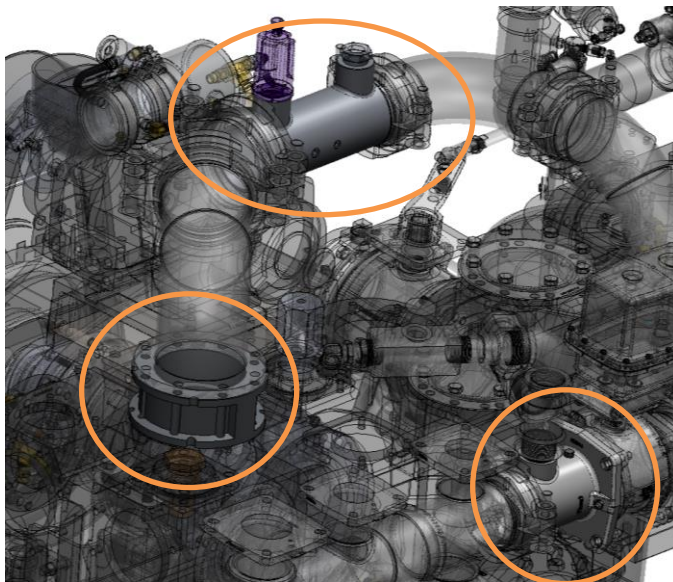

<b>PART NUMBER</b>	<b>SINGLE CHECK: 538-1850-00-0</b> <b>DOUBLE CHECK: 538-1840-00-0</b> <b>4" WAFER: 038-1570-04-0</b> <b>4" WAFER QTWO: 538-00038-001</b> <b>CAFS CHECK: 114666</b>
<b>DESCRIPTION</b>	Check Valves
<b>OPERATION</b>	The first two check valves isolate the pump from the foam, while the check valve after the ARC isolates the air from the foam. The configuration depends on the manifold ordered.
<b>POSSIBLE FAULT</b>	<ul style="list-style-type: none"> <li>• Check Valve failure can result in:             <ul style="list-style-type: none"> <li>○ Foam in the pump body</li> <li>○ Poor CAFS pressure matching</li> </ul> </li> </ul>

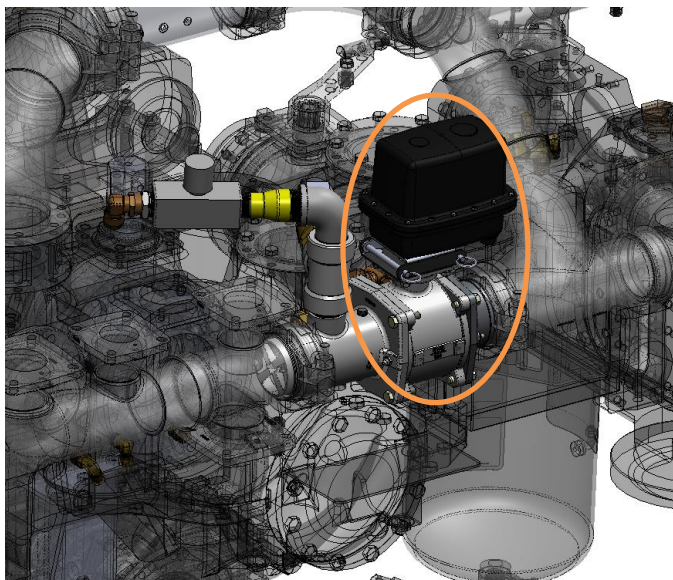

<b>PART NUMBER</b>	<b>538-1900-05-0</b>
<b>DESCRIPTION</b>	ARC VALVE
<b>OPERATION</b>	ARC valve controls the air/water ratio for CAFS operation. It automatically goes to full open when CAFS is not in operation. It is CAN controlled by the UV display. Bypass is installed for fine tuning (factory set).
<b>POSSIBLE FAULT</b>	<ul style="list-style-type: none"> <li>• Poor CAFS performance             <ul style="list-style-type: none"> <li>○ ARC is stuck                 <ul style="list-style-type: none"> <li>▪ (Remove actuator and loosen with 3/4" wrench being careful to keep the valve orientation the same when replacing valve.</li> <li>▪ Grease valve</li> </ul> </li> <li>○ No signal to ARC valve</li> </ul> </li> </ul>

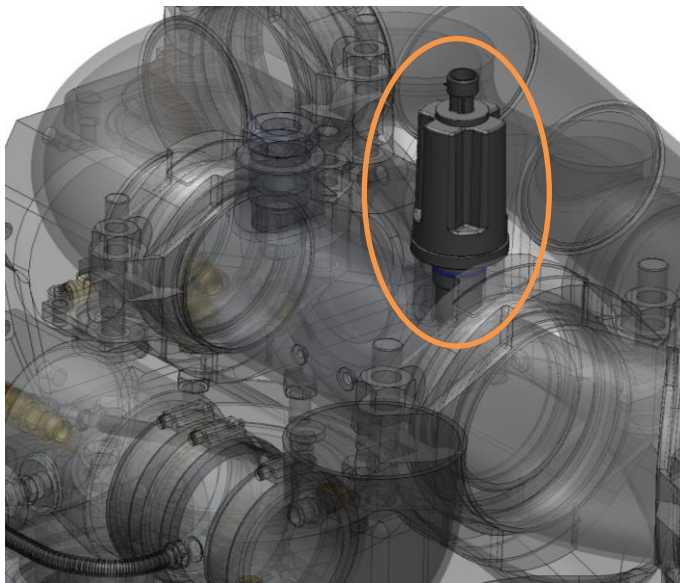

<b>PART NUMBER</b>	<b>STANDARD: 102714</b> <b>HIGH PRESSURE KIT: 8713198-1</b>
<b>DESCRIPTION</b>	Paddlewheel
<b>OPERATION</b>	Paddlewheel measures the water flow before foam and air injection. The high pressure kit is for qtwo and other high pressure pump applications.
<b>POSSIBLE FAULT</b>	<ul style="list-style-type: none"> <li>• No signal from paddlewheel can result in:               <ul style="list-style-type: none"> <li>○ No foam injection</li> <li>○ No air injection</li> </ul> </li> <li>• Poor CAFS performance               <ul style="list-style-type: none"> <li>○ Paddlewheel is out of calibration</li> <li>○ Not properly grounded (can result in large jumps in the water flow reading).</li> </ul> </li> </ul>

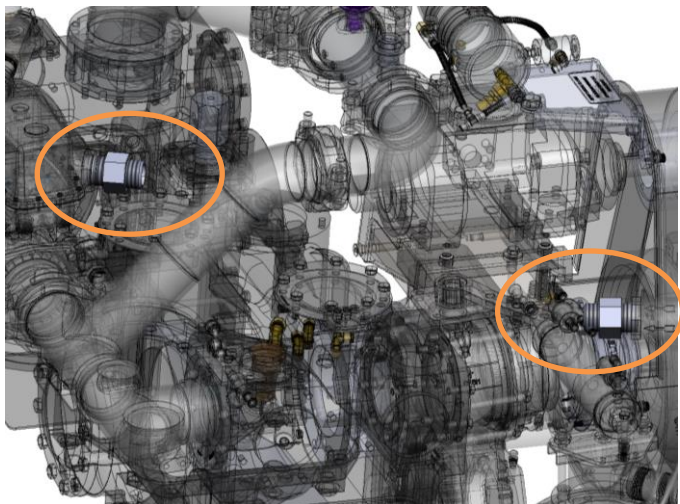

<b>PART NUMBER</b>	<b>STANDARD: 038-1631-02-0</b>
<b>DESCRIPTION</b>	Air Inject Check Valve
<b>OPERATION</b>	Air inject check valve prevents water from entering the oil separator.
<b>POSSIBLE FAULT</b>	<ul style="list-style-type: none"> <li>• Check Valve failure can result in:               <ul style="list-style-type: none"> <li>○ Water in the Oil Separator</li> <li>○ Poor CAFS pressure matching</li> </ul> </li> </ul>

## LIMITED WARRANTY

### Express Warranty

**EXPRESS WARRANTY:** Hale Products, Inc. (HALE) hereby warrants to the original Buyer that products manufactured by Hale are free of defects in material and workmanship for one (1) year. The "Warranty Period" commences on the date the original Buyer takes delivery of the product from the manufacturer.

**LIMITATIONS:** Hale's obligation is expressly conditioned on the Product being:

- Subjected to normal use and service.
- Properly installed, maintained in accordance with Hale's Instruction Manual as to recommended services and procedures.
- Not damaged due to abuse, misuse, negligence, or accidental causes.
- Not altered, modified, serviced (non-routine) or repaired other than by an Authorized Service Facility.
- Manufactured per design and specifications submitted by the original Buyer.

THE ABOVE EXPRESS LIMITED WARRANTY IS EXCLUSIVE. NO OTHER EXPRESS WARRANTIES ARE MADE. SPECIFICALLY EXCLUDED ARE ANY IMPLIED WARRANTIES INCLUDING, WITHOUT LIMITATIONS, THE IMPLIED WARRANTIES OF MERCHANTABILITY OF FITNESS FOR A PARTICULAR PURPOSE OR USE; QUALITY; COURSE OF DEALING; USAGE OF TRADE; OR PATENT INFRINGEMENT FOR A PRODUCT MANUFACTURED TO ORIGINAL BUYER'S DESIGN AND SPECIFICATIONS.

**EXCLUSIVE REMEDIES:** If Buyer promptly notifies HALE upon discovery of any such defect (within the Warranty Period), the following terms shall apply:

- Any notice to HALE must be in writing, identifying the Product (or component) claimed defected and circumstances surrounding its failure.
- HALE reserves the right to physically inspect the Product and require Buyer to return same to HALE's plant or other Authorized Service Facility.
- In such event, Buyer must notify HALE for a Returned Goods Authorization Number and Buyer must return the product F.O.B. within thirty (30) days thereof.
- If determined defective, HALE shall, at its option, repair or replace the Product, or refund the purchase price (less allowance for depreciation).
- Absent proper notice *within* the Warranty Period, HALE shall have no further liability or obligation to Buyer therefore.

THE REMEDIES PROVIDED ARE THE SOLE AND EXCLUSIVE REMEDIES AVAILABLE. IN NO EVENT SHALL HALE BE LIABLE FOR INCIDENTAL OR CONSEQUENTIAL DAMAGE INCLUDING, WITHOUT LIMITATION, LOSS OF LIFE; PERSONAL INJURY; DAMAGE TO REAL OR PERSONAL PROPERTY DUE TO WATER OR FIRE; TRADE OR OTHER COMMERCIAL LOSSES ARISING, DIRECTLY OR INDIRECTLY, OUT OF PRODUCT FAILURE.