

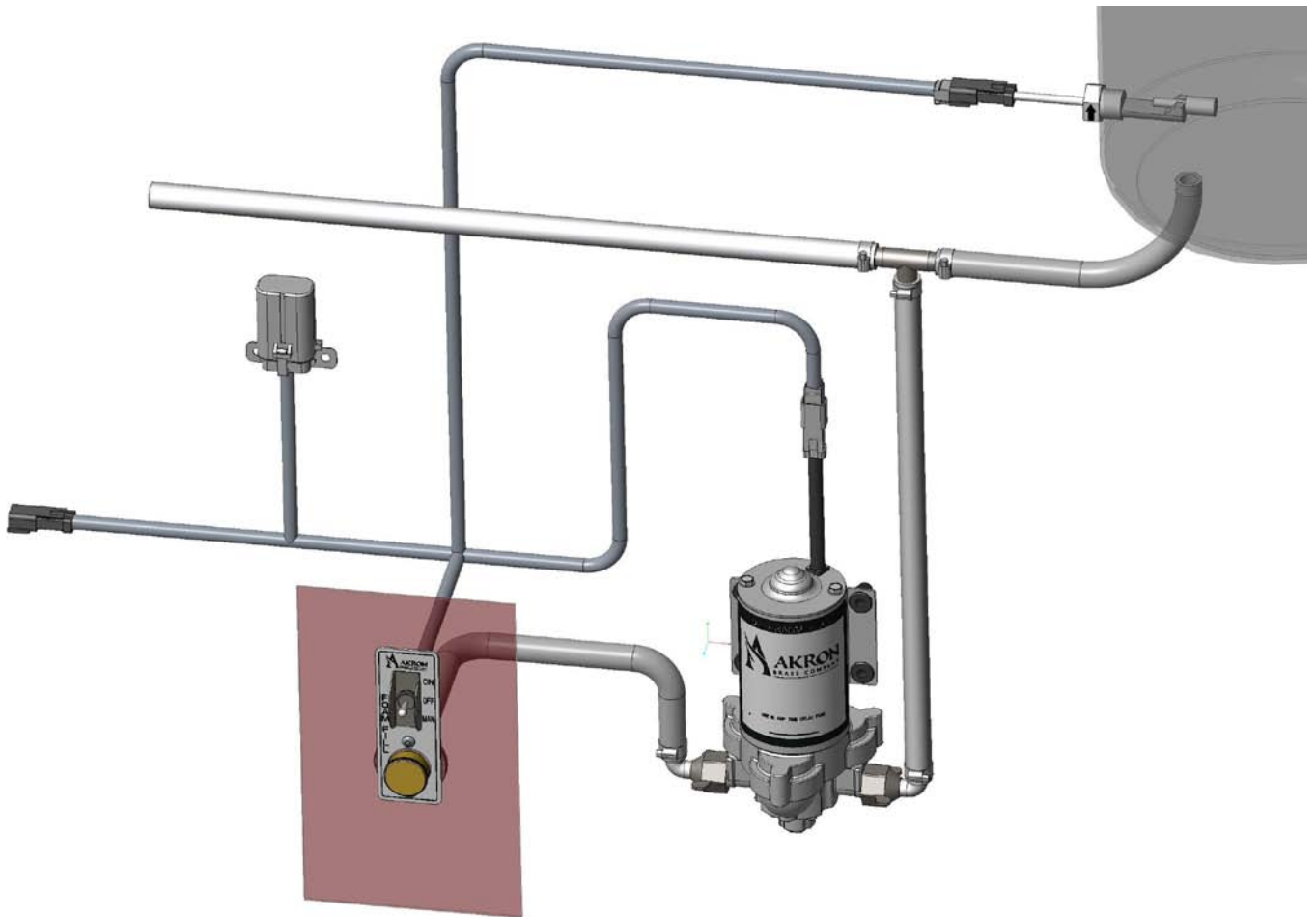

ARFS Rapid Fill™ Foam Tank Refill System INSTALLATION AND OPERATING INSTRUCTIONS

The following is intended to provide the basic instructions for installation, operation, and maintenance. Read and understand these operating instructions before use.



WARNING

Read and follow the operating instructions before use.



WARNING

For firefighting use only.

PHONE: 330.264.5678 or 800.228.1161 | FAX: 330.264.2944 or 800.531.7335

www.akronbrass.com



ARFS Rapid Fill™ Foam Tank Refill System INSTALLATION AND OPERATING INSTRUCTIONS

Product Ratings

Electrical Specifications:

	12-VOLT SYSTEM (11-14 Volts DC)		24-VOLT SYSTEM (22-28 Volts DC)	
	Maximum Operating Current	Normal Operating Current	Maximum Operating Current	Normal Operating Current
Pump	10 Amps	1.0-2.0 Amps	6 Amps	0.5-1.5 Amps

Mechanical Specifications:

Parameter	US Measure	Metric Measure
Flow Rate	3.3 GPM*	12.5 LPM*

*High viscosity foams will decrease flow rate

NOT RECOMMENDED FOR FOAMS WITH VISCOSITY GREATER THAN 1000 CPS

Tools Required

- Utility Knife
- Drill
- 3/16" Drill Bit
- 1/2" Drill Bit
- 1-3/16" Bit
- Medium flat screwdriver
- Standard Pliers
- 23/32" Drill Bit
- 1/2-14 NPT Tap

Also Required

- Thread sealing tape (PTFE tape)

PHONE: 330.264.5678 or 800.228.1161 | FAX: 330.264.2944 or 800.531.7335

www.akronbrass.com



ARFS Rapid Fill™ Foam Tank Refill System INSTALLATION AND OPERATING INSTRUCTIONS

Product Warnings

⚠ DANGER

- Indicates a hazardous situation which, if not avoided, WILL result in death or serious injury.

⚠ WARNING

- Indicates a hazardous situation which, if not avoided, COULD result in death or serious injury.

⚠ CAUTION

- Indicates a potentially hazardous situation which, if not avoided, may result in minor or moderate injury.

NOTICE

- Addresses practices not related to personal injury.

⚠ WARNING

- Make the connection of the power source at the final step.

⚠ WARNING

- Disconnect power and disable flow before maintenance.

⚠ WARNING

- Not designed for explosive environments.

⚠ WARNING

- Use only for firefighting by trained operators.

⚠ WARNING

- Not intended to be used during emergency situations.

NOTICE

- Replace the identification tags if they should become worn or damaged.

NOTICE

- For use with standard firefighting foams only.

PHONE: 330.264.5678 or 800.228.1161 | FAX: 330.264.2944 or 800.531.7335

www.akronbrass.com



ARFS Rapid Fill™ Foam Tank Refill System INSTALLATION AND OPERATING INSTRUCTIONS

Installation

Pump Installation

The pump should be located in an area that is dry and provides adequate ventilation. If mounted within an enclosure, provisions to cool the motor may be necessary. The pump may be mounted in any position. However, if mounting the pump vertically, the pump head should be in the down position.

Locate the desired location to mount the pump. Drill four 3/16" holes and use #8 hardware to secure the rubber feet to the mounting surface. Do not over-compress the feet; doing so will reduce their ability to isolate vibration/noise.

The pump is self priming. Horizontal and vertical prime vary depending on the fluid viscosity and pump configuration.

Figure 1

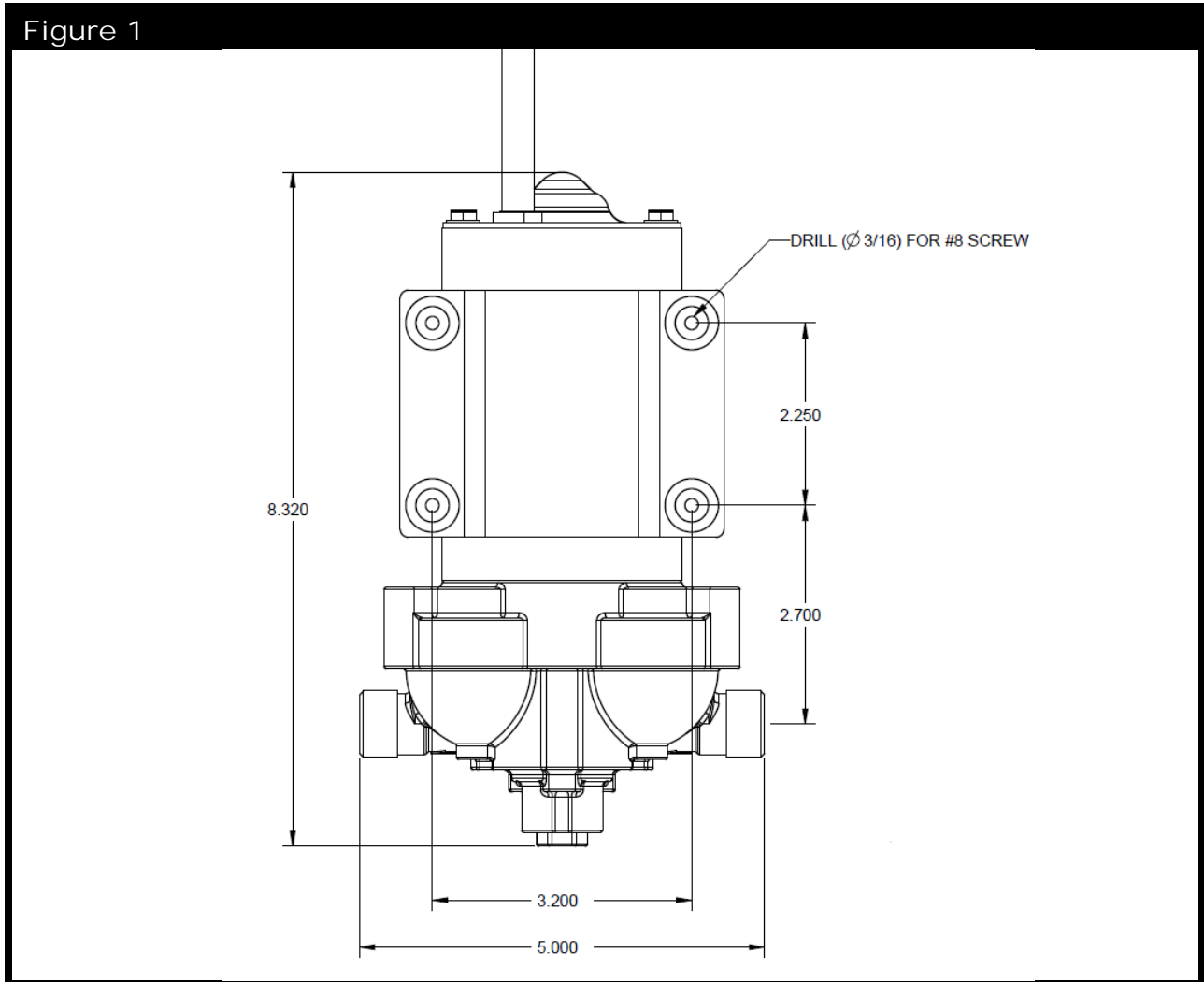

PHONE: 330.264.5678 or 800.228.1161 | FAX: 330.264.2944 or 800.531.7335

www.akronbrass.com



ARFS Rapid Fill™ Foam Tank Refill System INSTALLATION AND OPERATING INSTRUCTIONS

Panel Installation

Determine the desired location for the foam pump controls on the panel. Using the label as a template, mark and drill holes for the bulkhead adapter and toggle switch. Peel off the removable backing from the label and attach to the panel. Next install the toggle switch; ensure that the momentary on corresponds with the manual setting (MAN) on the label. Finally, install the bulkhead adapter securely to the panel using #10 hardware.

Figure 2

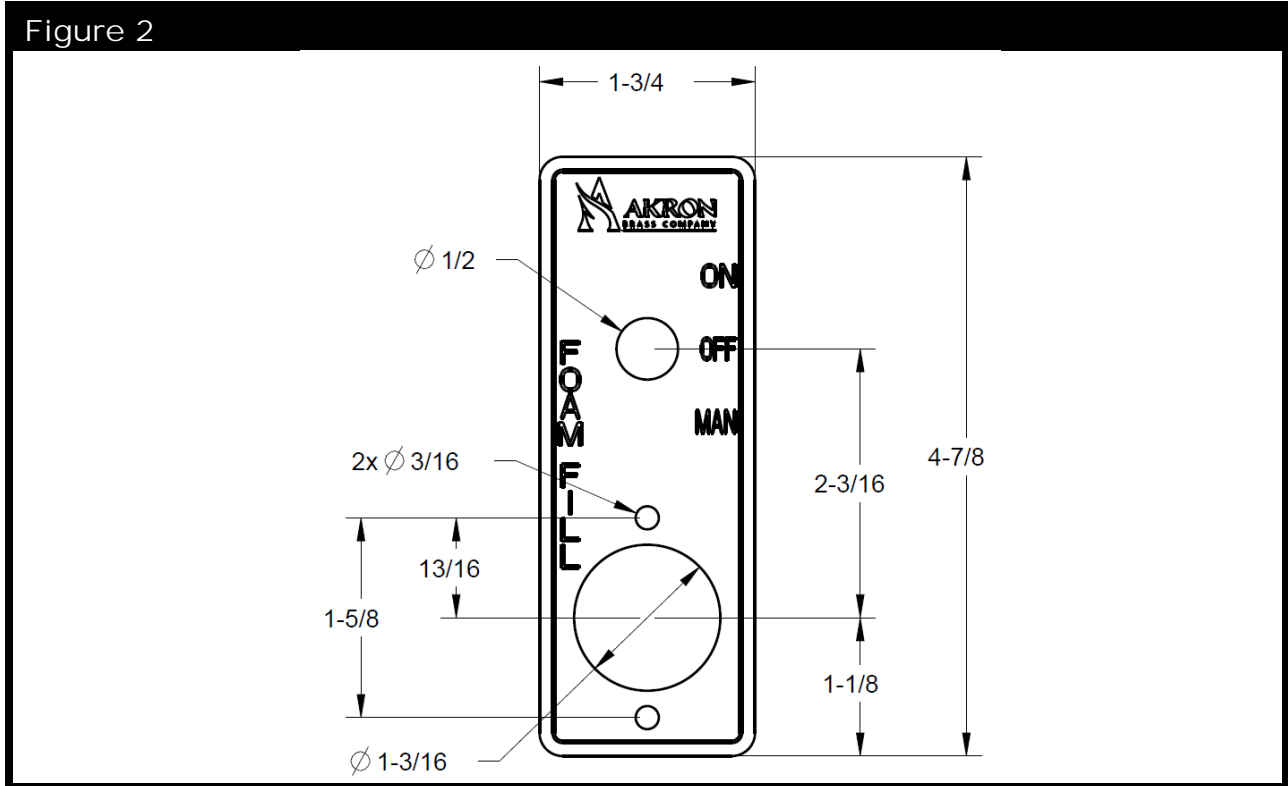

PHONE: 330.264.5678 or 800.228.1161 | FAX: 330.264.2944 or 800.531.7335

www.akronbrass.com



ARFS Rapid Fill™ Foam Tank Refill System INSTALLATION AND OPERATING INSTRUCTIONS

Tank Switch Installation

The tank switch communicates to the pump when the tank is full when the toggle switch is in the “ON” position. The tank switch should be installed near the top of the tank. Drill and tap the tank to accept ½-14 NPT threads; a thread sealer such as PTFE tape should be used. Ensure the arrows located on the hex of the tank switch are pointing upwards.

Figure 3

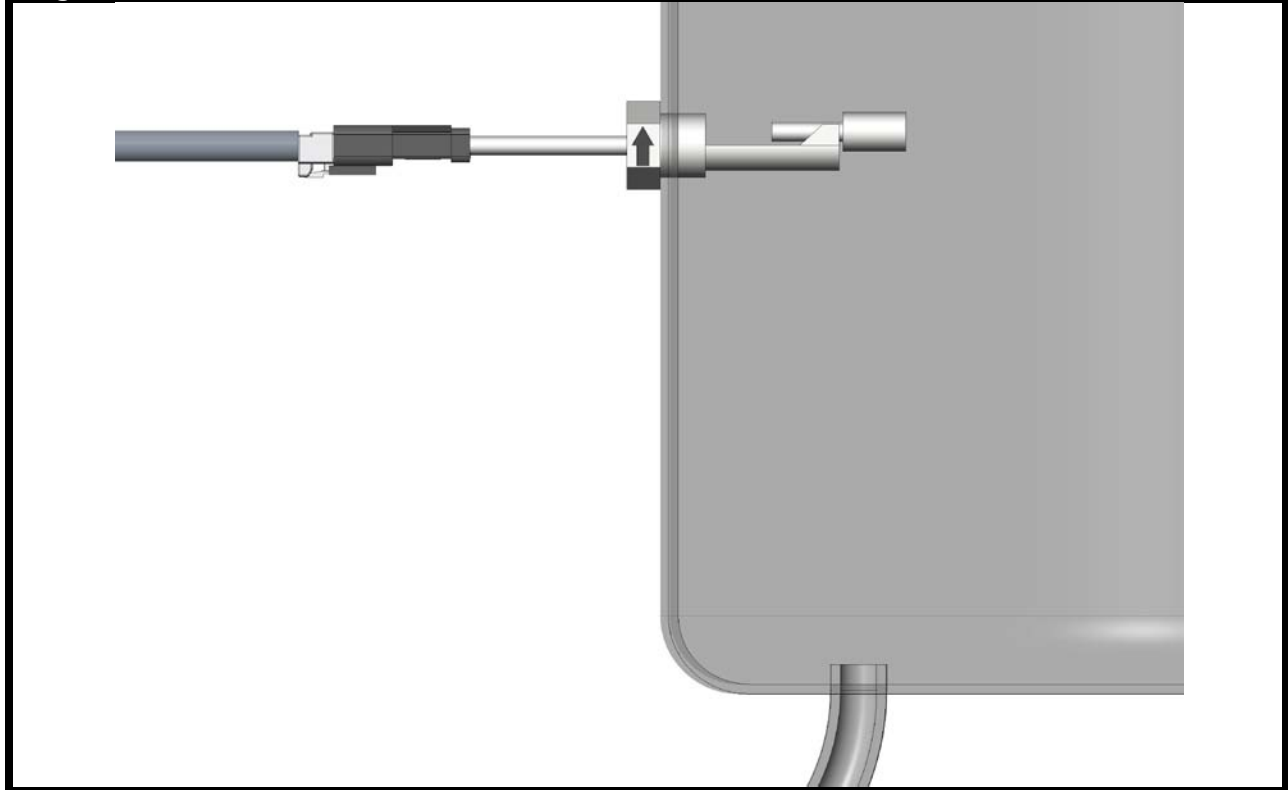

Hose Installation

Determine the length of hose required from the panel mount to the pump. Cut the required length from the supplied hose and connect the bulkhead adapter and pump using the supplied pipe clamps and fittings. Note the direction of flow labeled with arrows on the pump housing. Use the remaining section of hose and the supplied barbed tee to tie into the existing foam supply line.

PHONE: 330.264.5678 or 800.228.1161 | FAX: 330.264.2944 or 800.531.7335

www.akronbrass.com



ARFS Rapid Fill™ Foam Tank Refill System INSTALLATION AND OPERATING INSTRUCTIONS

Harness Installation

Connect the harness to the pump and tank switch. Mount the fuse/relay box in an accessible location. With the toggle switch in the “OFF” position, attach to the power supply. Ensure that the pump turns on when the toggle switch is set to the “ON” position. Finish installation by installing the supplied cap onto the foam inlet port.

Operating Instructions

Remove the cap from the foam inlet port and attach the pick-up tube assembly. Insert the free end of the pick-up tube assembly into the container of firefighting foam. Put the toggle switch in the “ON” position. The pump will continue pumping until the foam reaches the tank switch. The “MAN” position will allow the pump to run whether the tank switch is activated or not.

When finished pumping, set the toggle switch to the “OFF” position and remove the pick-up hose from the foam inlet port and replace the cap.

Warranty Statement

WARRANTY AND DISCLAIMER*: We warrant Akron Brass products for a period of five (5) years* after purchase against defects in materials or workmanship. Akron Brass will repair or replace product which fails to satisfy this warranty. Repair or replacement shall be at the discretion of Akron Brass. Products must be promptly returned to Akron Brass for warranty service. We will not be responsible for: wear and tear; any improper installation, use, maintenance or storage; negligence of the owner or user; repair or modification after delivery; failure to follow our instructions or recommendations; or anything else beyond our control. WE MAKE NO WARRANTIES, EXPRESS OR IMPLIED, OTHER THAN THOSE INCLUDED IN THIS WARRANTY STATEMENT, AND WE DISCLAIM ANY IMPLIED WARRANTY OF MERCHANTABILITY OR FITNESS FOR ANY PARTICULAR PURPOSE. Further, we will not be responsible for any consequential, incidental or indirect damages (including, but not limited to, any loss of profits) from any cause whatsoever. No person has authority to change this warranty. Unless otherwise provided herein. Akron Brass industrial electronic components & the Severe-Duty Monitor have a one (1) year warranty. Select Akron Brass handline nozzles and valves carry a ten (10) year warranty. Weldon products have a two (2) year warranty from date of manufacture (excluding consumable components). Select Weldon LED products carry a five (5) year warranty. Honda products have the manufacturers' warranty and Akron Brass disclaims any warranty in respect of those products.

PHONE: 330.264.5678 or 800.228.1161 | FAX: 330.264.2944 or 800.531.7335

www.akronbrass.com



ARFS Rapid Fill™ Foam Tank Refill System INSTALLATION AND OPERATING INSTRUCTIONS

Revision History

Revision	Reason Updated
02/18/16	New Instruction

PHONE: 330.264.5678 or 800.228.1161 | FAX: 330.264.2944 or 800.531.7335

www.akronbrass.com