



STYLE 9305 FLOW NAVIGATOR 12 OR 24 VDC LPM / kPa - bar COMBINATION ELECTRIC VALVE FLOW / PRESSURE SYSTEM INSTALLATION, CALIBRATION AND OPERATING INSTRUCTIONS

SECTION I INSTALLATION INSTRUCTIONS

A. **SYSTEM COMPONENTS**

Flow Navigator (Comb. Valve Controller/Meter)
Valve Actuator (Electric)
Wiring Harness
2 - Cables
Flow Sensor
Pressure Transducer
Valve Adapters with Flow Sensor ports, Saddle Clamps or Weld Boss

NOTE: The Flow Navigator is designed for use only with Akron Style 7820 - 7840 and 8820 - 8840 Swing-Out Valves and 7940 - 7960 Butterfly Valves stamped 64:1 on actuator. DO NOT USE THE FLOW NAVIGATOR ON 4" - 6" VALVES THAT ARE NOT MARKED 64:1

B. **FLOW SENSOR LOCATION**

Akron's Flow Sensors can be installed in one of three ways:

1. Akron's specially designed inlet adapters for Swing-out Valves. (See current catalog for a complete listing.)
2. Saddle Clamps. Size 2" - 5" (Schedule 40 pipe)
3. Weld Bosses - 4", 4 1/2" and 5" O.D. 1/8" walled aluminum on 4" Schedule 40 pipe.

Note: Horizontal installations must position the Flow Sensor port within 180° on topside (9:00 - 3:00).

Things to Avoid

- Installations where the Flow Sensor would be located in a line where a smaller line precedes it.
- Installations where the Flow Sensor would be positioned following a valve or elbow.
- Installations where the Flow Sensor would directly precede a Bypass Eductor.

C. **FLOW SENSOR INSTALLATION**

1. Akron Valve Adapter
 - a. Remove the retainer nut or plug.
 - b. Grease the O-Rings on the Flow Sensor with O-Ring lube or silicone grease.
 - c. Insert the Flow Sensor into the port and push in.
 - d. Seat alignment in locator hole (Figure 2) and push in.
 - e. Replace the retainer nut or plug and tighten with a wrench.
Sensor Installation is Complete
2. Saddle Clamp
 - a. Determine the location on the pipe.
 - b. Drill a 1-1/4" hole in the pipe with a hole saw.
 - c. Deburr the edge of the hole and clean the area where the gasket seals.
 - d. Center the saddle with the hole in the pipe
 - e. Insert the strap into the saddle and hand tighten the nuts.

- f. Using a torque wrench tighten nuts alternately to 80 foot pounds.
- g. Follow steps in C.1 to add the Flow Sensor.
Flow Sensor Installation Complete

3. Weld Bosses

Flow Sensor Weld Bosses are available for 4", 4 1/2" and 5" O.D. 1/8" wall aluminum and 4" Schedule 40 steel pipe. Detailed installation instructions for each option is included with each Weld Boss ordered from Akron.

E. PRESSURE TRANSDUCER INSTALLATION

CAUTION: Water trapped inside the Pressure Transducer will cause permanent damage if frozen.

1. Install the Pressure Transducer on the discharge side of the valve. The Pressure Transducer should be located as close to the valve adapter as possible to assure accurate readings. The Transducer should be mounted as near vertical as possible -not exceeding the 10 to 2 o'clock position. Be sure the placement of the Pressure Transducer allows for proper draining. If the Transducer is improperly installed freezing conditions can damage the unit.

Note: Placing the Pressure Transducer in a drain line away from the valve adapter is not recommended.

- 2. Apply pipe sealant to the thread and insert into provided tapped hole in valve discharge adapter on discharge side of valve.
- 3. Tighten with wrench to torque used for small pipe fittings.

Pressure Transducer Installation is now Complete

F. FLOW NAVIGATOR INSTALLATION

- 1. Select the mounting location on the control panel for the Flow Navigator. The Flow Navigator is mounted from the outside of the panel and will need a clear space behind the mounting position of 2 1/2". The dimensions of the panel cutouts for the Flow Navigator housing and mounting screws are shown on the attached template (Fig. 1). If not already made these holes should be cut at this time. **WARNING:** The Flow Navigator is a sealed unit and should not be disassembled. Disassembly may damage the seal, which can result in a malfunction.
- 2. Attach the Flow Navigator to the panel using the four screws provided.
- 3. Connect the 12 VDC electrical system of the apparatus to the Flow Navigator. Use the proper wire gauge when connecting the controller to the power hook-up. Depending on the distance of the controller from the power source, the following wire gauge size is recommended.

- 6 feet or less - 16 AWG or heavier
- 10 feet or less - 14 AWG or heavier
- 15 feet or less - 12 AWG or heavier
- 25 feet or less - 10 AWG or heavier

NOTE: Any intermediate connections or loads between Flow Navigator and power source can impact operation of the Flow Navigator.

It is recommended that direct runs be used for all connections. Do not splice. Use good weatherproof connections. (Flow Navigator supplied with Weatherpack connector.) A minimum of 11.5 volts is required under full load (28 amps). Typical current draw is 2 to 4 amps during normal travel; however, when the mechanical stop is contacted current draw can reach 28 amps. This will activate the red and green lights on the controller. For maximum performance, engine should always be running when operating the valves.

CAUTION: Exercise caution when working with the truck electrical system. Disconnect cable from truck battery positive terminal before connecting power to Flow Navigator. See truck manual for additional information.

- 4. Connect the Flow and Pressure Cables to marked connectors on the Controller.
- 5. Use a 10 foot Wiring Harness to connect the Valve Motor and Controller. If more than 20' is required between the Controller and the Valve, a special Wiring Harness is required. These special Harness' are available up to 50'. Contact Customer Service for details.

CAUTION: Do not use a Flow Navigator through slip (collector) rings as voltage drop will be increased. If a Controller is required beyond a slip ring, it is recommended an Auxiliary Controller be used.

- 6. Once installation is complete, operate the valve control open/close switches through a complete cycle to be sure the valve is operating properly and to calibrate valve position readout.

**SECTION II
FLOW/PRESSURE METER CALIBRATION INSTRUCTIONS**

General - When unit is in Calibration mode, all mode lights on left side of display will be illuminated. A flashing mode light indicates what function is being calibrated.

A. PRESSURE CALIBRATION

- 1. Open the valve and drain to eliminate any pressure in line.
- 2. Power up the meter.

Figure 1

FLOW-NAVIGATOR INSTALLATION TEMPLATE

**FLOW NAVIGATOR
INSTALLATION DIAGRAM**

NOT TO SCALE

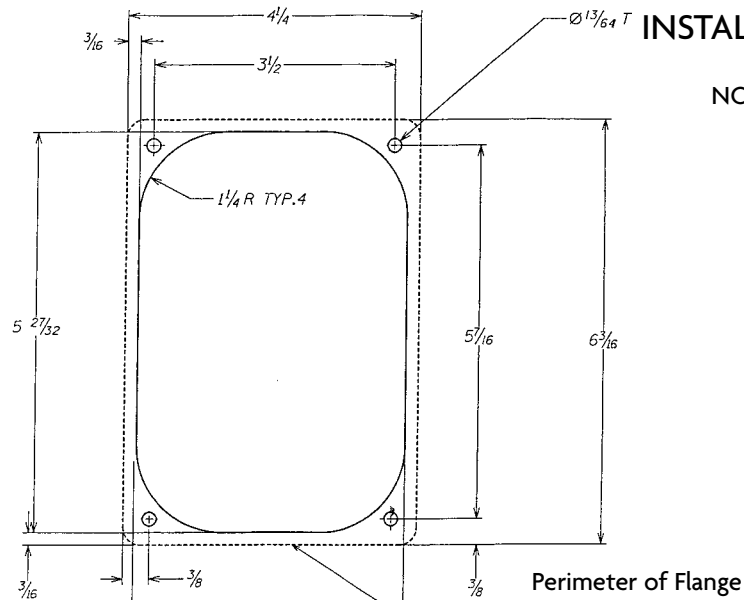

ELECTRIC VALVE FUNCTIONS

SYMPTOM	CAUSES	SOLUTION
Red and green lights do not illuminate, but valve will open and close.	<ol style="list-style-type: none"> 1. Low voltage. 2. LED's burned out. 	<ol style="list-style-type: none"> 1. Truck engine must be running. 2. Check voltage and amps to meter. Controller required 11.5 volts and 28 amps. 3. Jump a positive and ground cable from the controller to the battery + & -. Use a minimum 12 gauge wire up to 20 feet away. If controller operates properly during this test, check the wire gauge used from the battery to the terminal strip or junction box. It may not be heavy enough for all electrical requirements. Also, check for poor connections and improper ground.
Red and green lights illuminate prematurely. (Before valve is fully opened or closed.)	<ol style="list-style-type: none"> 1. Short in motor or controller. 2. Damaged actuator. 3. Gear system jammed. 4. Seat or ball damage. 	<ol style="list-style-type: none"> 1. Motor - Remove motor from gearbox. Measure current required to operate motor. Should be 1.5 amps. 2. Controller - Remove four bezel screws. Check inside of controller for water or signs that water may have been present. 3. Actuator or gear damage - Remove gear cover. Check operation using a $7/16$" wrench. It should turn easily with no binding. Look for bent shaft or gear tooth breakage. Also, check for gear sector crack at trunnion mounting square. 4. Check valve seats and valve ball for damage.
Yellow light illuminated, but valve does not open or close. (motor continues to run) Actuator moves at end of open or closed function.	<p>Worm shaft, worm or gear disengaged</p> <p>Some motion is normal from torque. However, if it appears to be excessive, screws may be loose where mounted to valve body.</p>	<p>Remove gear cover. Check shaft and worm pin for disengagement. Also, check gear for disengagement.</p> <p>Remove cover from sector housing. Remove four socket head cap screws and lift actuator off. Manually rotate the sector to remove one screw. Apply PermaBond LM113 or Loctite 222 on screws reassemble. NOTE: On the 4" Swing-Out Valve, also remove the adapter mounting plate under the gear housing and put the adhesive on those screws.</p>
Controller shows no power.	Power break or damaged PC board	Check power connections. Check inside of controller for water or water damage.

If any portion of the fire fighting device is not operational, do not use the product in a fire fighting application. Have it repaired and re-tested before placing it back into service.

All products rigidly attached to fire trucks should be installed, as per good engineering installation practices.

Ensure the valve is mounted far enough away from the engines or exhaust systems, to ensure rubber or plastic parts do not degrade with the excessive temperature encountered.

Do not use other controllers to operate Akron Brass valves.

SPECIFICATIONS

Sensor Types

Flow Meter - Paddlewheel

Pressure Transducer - Ratio Metric, 0.5 - 4.5 VDC, 1/4" NPT, Male, 0-4200 kPa.

Flow Navigator

Operating Voltage 12 VDC

Minimum Operations Voltage - 11.5 VDC

Maximum Operations Voltage - 32 VDC

Operating Current - 150 MA Flow Meter

Display Type - LED

Operating Temp. - 40 °F - 140 °F

**SECTION V
TROUBLESHOOTING GUIDE**

FLOW/PRESSURE FUNCTIONS

SYMPTOM	CAUSE	
Display does not illuminate	1. Power Connection 2. Power Source	If problems exist with power check, correct them. Replace Meter if power check is ok.
GPM shows 0-water is flowing	1. Cable Connections 2. Shut down pump - remove sensor - spin paddlewheel 3. Remove sensor from cable connect direct to meter spin paddlewheel	If display shows reading, replace cable. If not, replace sensor.
LED Dim	Hold left button down for 5 seconds. Should brighten.	
LENS Foggy	Should dissipate shortly after use with LED's lighted.	Will cause no harm. This will happen if meter is not assembled in a humidity free area.
dEAD, EprL, EprH Appears on display	1. Check pressure transducer connections 2. Shutdown pump remove transducer and connect directly to meter	If display clears, replace cable. If it does not, replace transducer.

dEAd - Hardware problem. Probably meter.
EprL - 1. Short to ground. Check cable.
2. Not ZEROED at 0 kPa or bar
3. Check for vacuum in line

EprH - 1. Transducer not installed.
2. Short to power. Check cable.
3. Not ZEROED to 0 kPa or bar

- After the display has gone through a sequence of messages, 0 will appear on the display, or an error message may appear if in the pressure mode. Also, a mode light will appear on the left side of the display.

The unit is now ready for Pressure Calibration

- Step 1** - Press and hold **BOTH** Flow and Pressure buttons simultaneously for approximately 15 seconds, until the display flashes **CAL** (calibration). Release buttons. After a few seconds **SIZE** will appear on display and all mode lights will be illuminated.
- Step 2** - Press and release the **LEFT** button. **PRES** (pressure) will appear on the display.
- Step 3** - Press and release **RIGHT** button. **ZEro** (a digital display meaning “**ZERO**”) should appear and kPa or bar mode light will flash. Note: If “**ZERO**” does not appear, the messages **EPRO**, **EPRI**, or **EPR2** may appear on the display. They indicate possible transmission errors between the pressure transducer and the meter.
(See trouble shooting guide - Section IV to resolve)
- Step 4** - With “**ZERO**” appearing on display, press and release right (pressure) button. **ZERO** will start flashing. After a moment, **0** will appear on display.

Unit is now ready to provide pressure readings for operations. This procedure will only need to be repeated if the Pressure Transducer or Flow Meter is replaced.

B. FLOW CALIBRATION - PIPE SIZE

- Step 1** - Power up unit. No flow is required through system.
- Step 2** - Press and hold **BOTH** Flow and Pressure buttons simultaneously for 15 seconds until the display flashes **CAL** (calibration) release buttons. After a few seconds **SIZE** will appear on the display.
- Step 3** - Press and release **RIGHT** button, if unit had previously been programmed with a pipe size, that size will appear. If unit was not calibrated with pipe size, **CUS** (custom) will appear. Press and release left button. **FRE** (frequency) will appear. Proceed with Steps 4 & 5.
NOTE: Pipe size will be displayed as 0020 for 2" and 0025 for 2 1/2", etc.
- Step 4** - Press and release **LEFT** button until desired pipe size appears.
- Step 5** - With correct pipe size displayed, press and release **RIGHT** button, the pipe size will flash, then **0** will appear on display. Unit is now calibrated for pipe size.
- Step 6** - The accuracy of the installation should be checked, due to possible variations associated with individual installations. An Akron Water Flow Test Kit is recommended as the basis for comparison. If the Flow Meter does not agree the Water Flow Test Kit, recalibrate using the custom flow setting covered in the next section.

C. FLOW CALIBRATION - CUSTOM FLOW SETTINGS (HIGH/LOW)

For maximum accuracy of each flow line, (especially with elbows in line) it maybe desirable to set each discharge line to a given high flow/low flow range rather than using pipe size mode, this can be done utilizing the Akron Water Flow Test Kit. Once calibrated, unit will remain as set, unless new range is entered under calibration process.

Line Size	SUGGESTED FLOW RANGES	
	LPM Low Flow	LPM High Flow
2"	115	950
2-1/2"	230	2280
3"	600	4880
4"	950	7600
5"	950	7600

To explain this procedure, a 2-1/2" line with a 230 LPM low flow and 2800 LPM high flow will be used. **Note: 230 & 2280 only used to explain how to set. Use your own settings. High flow should be 7-10 times low flow setting. In custom calibration, both high and low must be set.**

- Step 1** - Power up unit.
- Step 2** - Press and hold **BOTH** buttons simultaneously for approximately 15 seconds, until the display flashes **CAL** (calibration). Release buttons. After a few seconds **SIZE** will appear on the display.
- Step 3** - Press and release **LEFT** button until **FLO** (flow) appears on the display.
- Step 4** - Press and release **RIGHT** button. **HIFL** (highflow) will appear on the display.
- Step 5** - Start up pump and commence discharge through selected discharge line with the Water Flow Test Kit connected according to instructions.
- Step 6** - Bring flow up to **2280 LPM** and maintain a steady flow. Use the Pressure/Flow Conversion Sheet provided with the Water Flow Test Kit.
- Step 7** - Press and release **RIGHT** button. The meter will begin to count pulses up to 1000. It will then stop and **HEND** (high end) will appear on display. If steady flow is not maintained during pulse counting, press and release **LEFT** button.

HIFL will appear on the display. Press and release RIGHT button to recollect 1000 pulses.

- Step 8 - After ensuring that a steady reading has been maintained through the count sequence, press and release RIGHT button to accept pulse data. **0000** will appear on the display, with far left **0** flashing.
- Step 9 - Since the display will show four characters and the high flow is 2280, press the left button until 2 appears.
- Step 10 - Press and release RIGHT button. The second **0** from left will begin flashing.
- Step 11 - Press and release the LEFT button until 2 appears.
- Step 12 - Press and release RIGHT button. The third **0** from left will begin flashing. Display should read 0220.
- Step 13 - Press and release RIGHT button. The right **0** will begin flashing. The display should read 2280.
- Step 14 - Press and release RIGHT button. 2280 will flash.
If other than 2280 is desired, use the LEFT button to change numbers and right button to change fields, as steps 9-13 explain.
- Step 15 - If value is correct, press and release RIGHT button. **LOFL** (low flow) will now appear on the display. Using the Pressure/Flow Conversion Sheet provided with the Water Flow Test Kit, hold flow at 230 LPM and maintain steady flow.
- Step 16 - Press and release RIGHT button. The meter will begin to count pulses to 1000. Note: The Low flow pulse collection will take longer than high flow due to lower velocity.
- Step 17 - When 1000 pulses have been reached, the counting will stop. **LEND** (low end) will appear on display.
- Step 18 - Press and release RIGHT button. **0000** will appear on the display. Proceed as you did in steps 9-13, display should show 0230 after step 12 using 0230 instead of 2280
- Step 19 - Press and release RIGHT button. 0230 will flash.
- Step 20 - Press and release RIGHT button. **CAL** (calibration) will flash momentarily, indicating that the meter is calibrated. Display will then show **0** with a mode indicator light.
- Step 21 - Verify Flow Meter calibration by comparing flows to the Akron Water Flow Test Kit. **Note: Pitot pressure at tip will not match surface pressure reading on meter, so disregard.**

Unit is now ready for use

NOTE: The high flow settings should be 7 - 10 times the low flow settings.

D. SETTING THE OPTIONAL AUTO OPEN FEATURE

Auto Open is not preset. The following steps must be preformed to establish the Auto Open feature:

To turn the Auto Open feature on:

1. Press and hold the Open and Close Buttons simultaneously for 30 seconds, until the Yellow Light begins to flash.
2. Press the Open Button (The Yellow and Green lights will flash alternately.)
3. Press and hold the Open and Close Buttons simultaneously for 3 seconds. The Yellow Light will flash initially then remain lit.
The Auto Open feature is now selected.

Cycle the Valve full open to full close one time.

To verify the Auto Open feature is on, with the Valve fully closed, touch the Open Button and the Valve will fully open. Note: The Auto Open feature will apply to any Auxiliary Controller but the set up must be done using the Master Controller.

To turn the Auto Open feature off:

1. Press and hold the Open and Close Buttons simultaneously for 30 seconds, until the Yellow Light begins to flash.
2. Press the Close Button (The Yellow and Red lights will flash alternately.)
3. Press and hold the Open and Close Buttons simultaneously for 3 seconds. The Yellow Light will flash initially then remain lit.

The Auto Open feature is now cancelled.

Cycle the Valve full open to full close one time.

To verify the Auto Open feature is off, with the Valve in the fully closed, touch and release the Open Button. The Valve movement will stop as soon as the button is released.

SECTION III VALVE OPERATING INSTRUCTIONS

The electrically actuated valve is operated by the momentary Open/Close switches, (Fig. 3) of the Flow Navigator mounted on the apparatus control panel. The controller features a lighted display indicating when the valve is fully open (Green), in a throttling position (Yellow) or fully closed (Red).

TO OPEN VALVE - Push the OPEN valve button, hold the button until the valve attains the desired position, then release the button.

TO CLOSE VALVE - Push the CLOSE valve button, hold the button until the valve attains the desired position, then release.

NOTE: A minimum of 11.5 volts and 28 amps are required to activate open/close (Green/red) lights. Valve will operate with less, but only yellow light will register due to current limiting design. (Engine should be running to insure proper light functions.)

MANUAL VALVE OPERATION - If the valve fails to operate during use, disconnect the electrical connector on the valve. With a 7/16" wrench, turn the hex head on the end of the motor drive shaft to open or close the valve.

DANGER - Always disconnect the electrical connector on the valve when the gear cover is removed.

KEEP FINGERS AWAY FROM THE MOVING GEARS!

FLOW/PRESSURE METER OPERATION INSTRUCTIONS

A. **GENERAL**

These instructions describe features and operational steps for general service after the system is set up and calibrated.

The meter consists of the display screen and two operation buttons located directly beneath the display.

When unit is powered, there are three red LED mode lights on the left side of display. Each of these lights align with particular function marked on the bezel face. They will only be illuminated individually, except during power up sequence and calibration.

The unit has four operation functions:

1. Flow **LPM** - Actual liters per minute flowing. (Displayed in increments of 1 LPM to 1200. 10 LPM increments above 1200.)
2. Flow **TOTAL** - Total liters flowed since unit was powered up. (Figure displayed must be multiplied X 100 to get total)
3. Pressure **kPa** or **bar** - Actual pounds per square inch pressure.
4. LED INTENSITY - Brightness of display.

B. **OPERATION**

At the time of power up, all three mode lights will appear with four zeros. In sequence a number value will appear, followed by **LPM**, **kPa** or bar, **CUS** or **PIPE** and finally **0**. This will be complete in a few seconds.

The unit is now ready for operation

TO READ:

LPM - Press and release **LEFT** (flow) button to place mode light on **LPM**. Actual **LPM** will appear on display.

TOTAL FLOW - Press and release **LEFT** (flow) button to place mode light on **TOTAL**. The figures displayed must be multiplied by 100 to give liters flowed.

kPa or **bar** - Press and release **RIGHT** (pressure) button to place mode light on **kPa** or bar. Actual pressure will appear on display.

LED INTENSITY - To brighten or dim **LED**, press and hold **LEFT** button until desired brightness is displayed.

Refer to Section V, Troubleshooting guide if problems occur.

NOTE: The Akron Electric Valve System is designed to be used with Akron components only. Other controls and actuators may not be used. No more than 20 feet separation may be used between the power source and the controller and the controller and the actuator. For greater distance separation, an auxiliary controller must be used up to 370 feet. Controller wiring harnesses to the actuator may not be spliced. Auxiliary controller cables must be used for connections through collector rings on aerial devices or other applications that require splicing.

CAUTION: Always disconnect all wiring and cables from the Flow Navigator before electric arc welding at any point on apparatus. Failure to do so will result in damage to the Flow Navigator.

SECTION IV GENERAL PRODUCT GUIDELINES

All fire fighting products should be carefully inspected after each use, in order to ensure no damage incurred, and they are in good working order. If not in good working order or damaged, the product should be repaired and re-tested to ensure the product meets the specification.

All Akron Brass fire fighting equipment should be operated by trained and knowledgeable fire fighters only.

All Akron Brass product is designed for fire fighting use only. If another application is anticipated, approval must be gained from Akron Brass.

All fire fighting products should be operated in accordance with nationally recognized standards and training manuals.

Figure 2

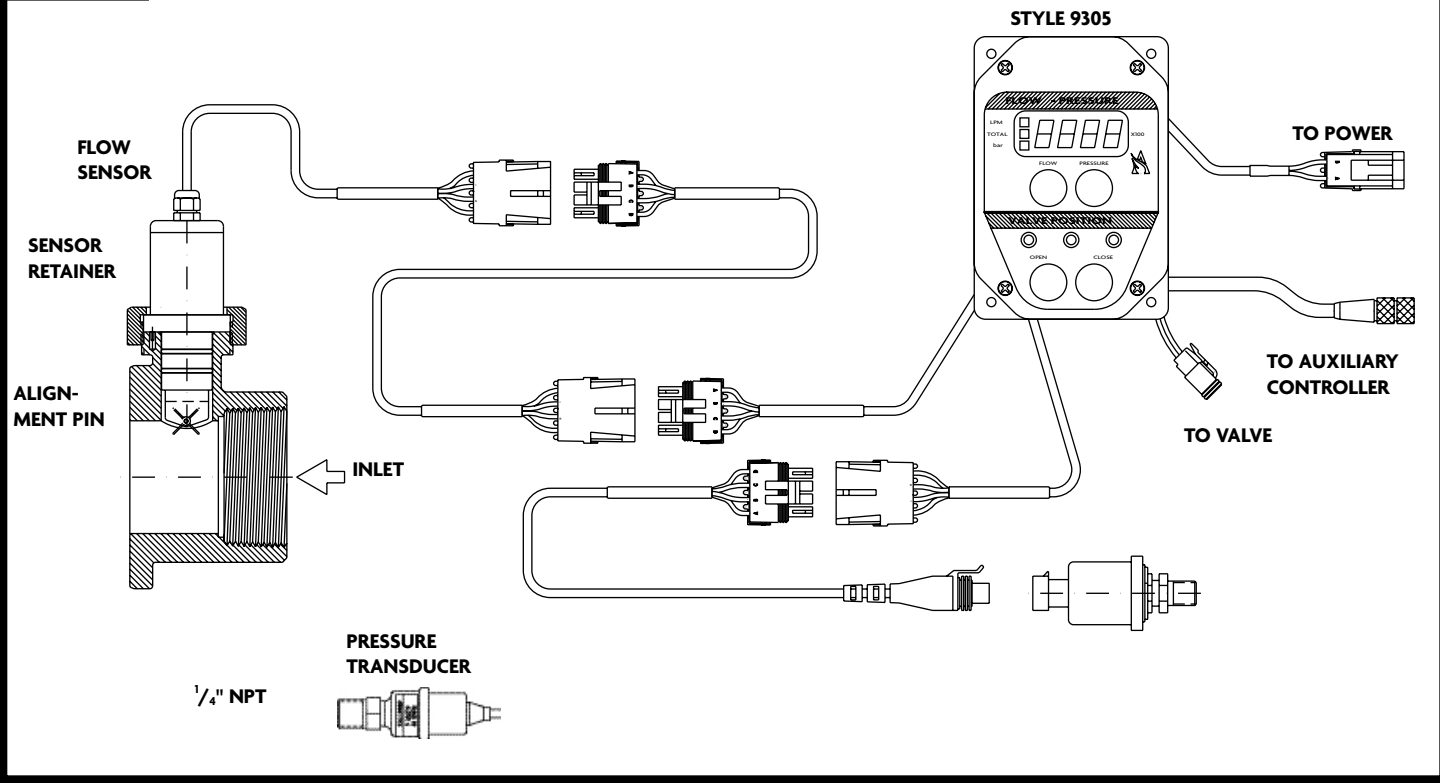

Figure 3

