

NOTE: This product model is no longer in production. For service and repair, please contact Akron's Customer Service at 800.228.1161 or 330.264.5678.

STYLE 5078
Electrically Controlled Akromatic® Nozzle

TECHNICAL SERVICE PARTS

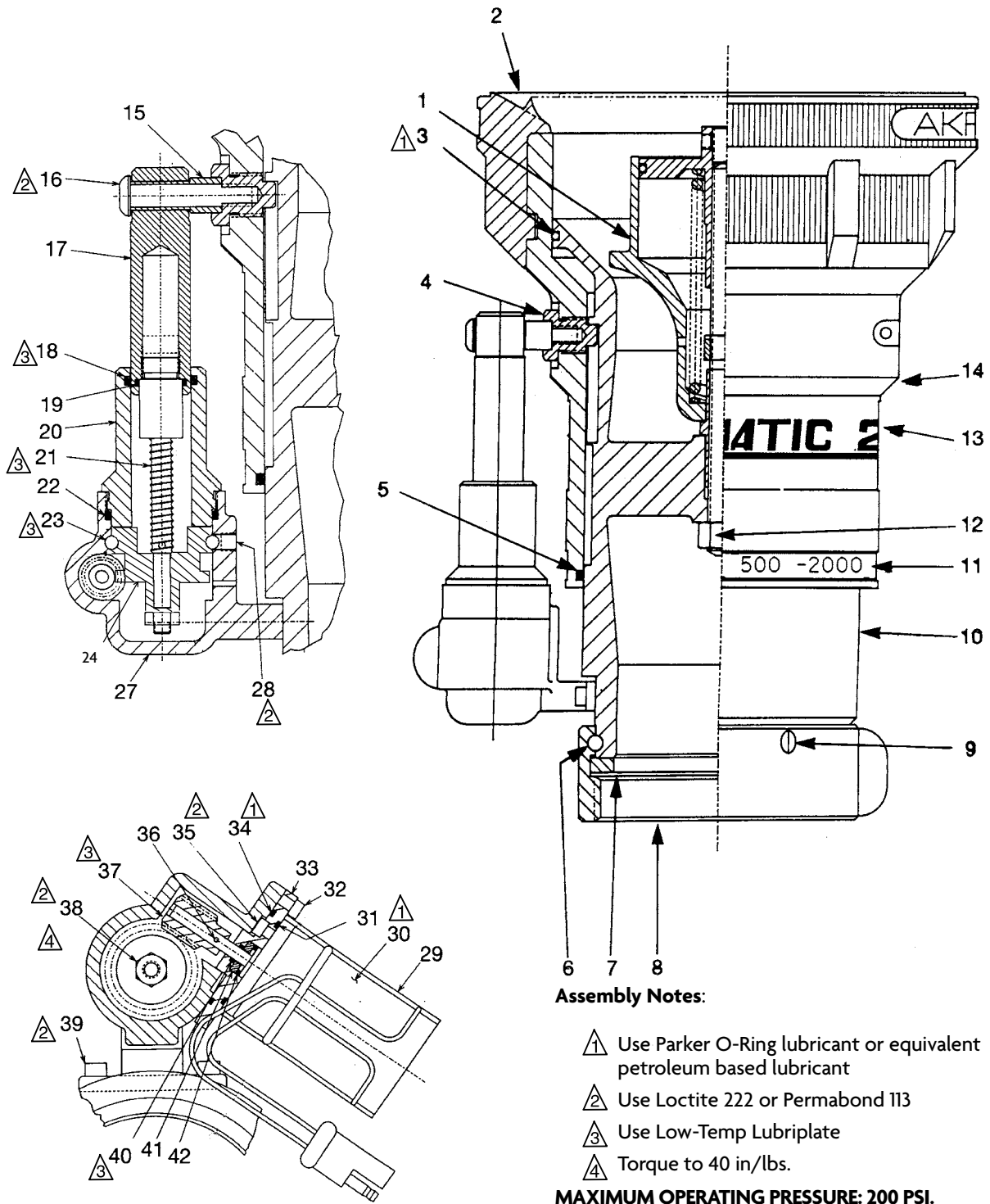

Assembly Notes:

- ⚠1 Use Parker O-Ring lubricant or equivalent petroleum based lubricant
- ⚠2 Use Loctite 222 or Permabond 113
- ⚠3 Use Low-Temp Lubriplate
- ⚠4 Torque to 40 in/lbs.

MAXIMUM OPERATING PRESSURE: 200 PSI.

FLOW RATING: 500-1200 or 500-2000 GPM at 80 PSI

WARNING: The electrical control system must incorporate a current limiting circuitry set for a maximum of 3 amps for 12 volts (1.5 amps for 24 volts). Without circuitry set motor may become inoperable if stalled during operation.



STYLE 5078
Electrically Controlled Akromatic® Nozzle
TECHNICAL SERVICE PARTS LIST

ITEM NO.	DESCRIPTION	PART NUMBER	QUANTITY
1	Baffle Assembly 2000 GPM	*	1
2	Bumper	*	1
3	O-Ring	757316	1
4	Pattern Stop	769509	1
5	Bearing	703443	1
6	Ball Bearing	**	53
7	Swivel Gasket	714023	1
8	Swivel 3-1/2 " NH	104014	1
9	Swivel Plug	742023	1
10	Throat	108389	1
11	Band	703449	1
12	Nut	734084	1
13	ID Band	704390	1
14	Pattern Sleeve	108386	1
15	Spacer	768257	1
16	Button Head Screw	766052	1
17	Screw Housing	108384	1
18	O-Ring	757293	1
19	O-Ring	757055	1
20	Tube Guide	108388	1
21	Drive Screw	767136	1
22	O-Ring	757048	1
23	Ball Bearings	704018	24
24	Gear	718191	1
27	Pattern Housing	108385	1
28	Socket Head Cap Screw	765134	1
29	Shrink Cap	707125	1
30	12V Motor Assembly	50770009	1
30	24V Motor Assembly	50770010	1
31	O-Ring	757317	1
32	Socket Head Cap Screw	765150	4
33	Motor Adapter	108383	1
34	O-Ring	757056	1
35	Socket Head Cap Screw	765175	4
36	Roll Pin	744341	1
37	Worm Gear	785021	1
38	Hex Nut	734061	1
39	Socket Head Cap Screw	763038	2
40	O-Ring	757318	1
41	Spacer	768258	1
42	O-Ring	757180	1
Not Shown	24V CE Tag	773318	1

*If repair is required entire nozzle must be returned to the factory.

**Packet of 50 Ball Bearings - P/N 109041



Tested..Proven..Trusted.

ISO 9001 REGISTERED COMPANY

PHONE: 330.264.5678 or 800.228.1161 | FAX: 330.264.2944 or 800.531.7335 | akronbrass.com

REVISED: 7/11

WARRANTY AND DISCLAIMER: We warrant Akron Brass products for a period of five (5) years after purchase against defects in materials or workmanship. Akron Brass will repair or replace product which fails to satisfy this warranty. Repair or replacement shall be at the discretion of Akron Brass. Products must be promptly returned to Akron Brass for warranty service.

We will not be responsible for: wear and tear; any improper installation, use, maintenance or storage; negligence of the owner or user; repair or modification after delivery; damage; failure to follow our instructions or recommendations; or anything else beyond our control. WE MAKE NO WARRANTIES, EXPRESS OR IMPLIED, OTHER THAN THOSE INCLUDED IN THIS WARRANTY STATEMENT, AND WE DISCLAIM ANY IMPLIED WARRANTY OF MERCHANTABILITY OR FITNESS FOR ANY PARTICULAR PURPOSE. Further, we will not be responsible for any consequential, incidental or indirect damages (including, but not limited to, any loss of profits) from any cause whatsoever. No person has authority to change this warranty.

© Akron Brass Company. 2011 All rights reserved. No portion of this can be reproduced without the express written consent of Akron Brass Company.