



STYLE 3679 CONQUEST™ INSTALLATION AND OPERATING INSTRUCTIONS

TOOLS REQUIRED

- Utility knife
- Medium Phillips screwdriver
- Small Phillips screwdriver
- Electrician's pliers (multipurpose, stripping and crimping)
- Medium flat screwdriver
- Small flat screwdriver
- 1/2 inch hex head wrench

The following is intended to provide the basic instructions for installation, operating, and maintenance of the Conquest.

PRODUCT RATINGS

Maximum motor current draw:

12 volt versions	14.0 amps each for elevation and rotation motors 3.0 amps for nozzle pattern motor
24 volt versions	7.0 amps each for elevation and rotation motors 1.5 amps for nozzle pattern motor

Normal operating current (depending on operating conditions—pressure, flow, etc.):

12 volt versions	3 - 10 amps each for elevation and rotation motors 0.7 amps for nozzle pattern motor
24 volt versions	1.5 - 5 amps each for elevation and rotation motors 0.35 amps for nozzle pattern motor

Minimum voltage: All 12 volt motors - 11.5 volts
All 24 volt motors - 23 volts

Maximum Flow: 2000 GPM

Maximum Pressure: 200 PSI

PRODUCT WARNINGS

- The maximum flow of the Conquest and Akromatic® 2000 is 2000 GPM. The center of the waterway outlet is 15 1/2 inches from the bottom of the inlet flange. Ensure these values and an appropriate safety factor is used to determine a proper support structure.
- Charge the Conquest slowly. Rapid charging may cause water hammer.
- Aim the Conquest in a safe direction before pumping water through it.
- Although the logic box includes a water resistant coating it is important to keep water out of the control and logic boxes. Prolonged exposure to water will cause damage. When the cover of the control or logic box is removed check that the O-Ring under the cover is intact and free of dirt and debris.
- The Conquest uses current limiting for both the monitor and nozzle stops. Use only appropriate Akron Brass® nozzles.
- Do not use the electric controls when the override cranks are being used or are in position for use.
- Make vehicle and auxiliary battery connection the final step.
- If any tags or bands are worn or damaged and cannot be easily read, they should be replaced.
- See inside page for dimensions.

GENERAL INSTRUCTIONS

- Review the instructions, wiring diagram, component layout and rotational stops diagram before installing this unit. This unit operates on 12 volt (or 24V optionally) DC. All electrical current flows through the wires. The monitor does not act as a ground. The wires from the control boxes can be cut to the length for the application plus 10 inches (see STEP 2). Do not extend the wires from the logic box to the monitor.
- The optional auxiliary battery is used to ensure that the proper voltage and current are maintained at the logic box when using a smaller gauge wire for the vehicle battery wires. If the optional auxiliary battery is used do not extend the auxiliary battery wires. This will ensure that the proper voltage and current are maintained at the monitor for it to operate properly. The optional battery is automatically recharged by the truck electrical system through the positive and ground connections on the circuit board. These connections must have power turned on whenever the truck is running so that the battery can be recharged properly. If possible, connect the positive wire directly to the main vehicle battery or main master switch. A diode in the logic box will prevent the optional battery from feeding current back into the main truck system.
- For firefighting by trained firefighters only.
- For use with water or standard fire fighting foams only. After use with foam, flush with fresh water.
- Do not use the Conquest nozzle as a forcible entry tool.
- Drain the Conquest monitor and nozzle after use to prevent “freeze damage”.
- Ensure that the thread in the nozzle swivel matches the thread on the Conquest outlet. Do not overtighten the nozzle onto the Conquest.
- The Conquest monitor, nozzle, logic box, control boxes, optional battery, and field adjustable rotation stops are made for optimal performance. Do not alter in any manner.
- Do not install shutoffs on the outlet of the Conquest.

ELECTRICAL INSTALLATION INSTRUCTIONS

CONTROL BOXES WIRING AND ATTACHMENT

The Conquest upper and lower controls use the same control box. The following steps will prepare either one or both control boxes for attachment to the logic box.

STEP 1 If the control box includes an attached cable skip to STEP 5.

STEP 2 Determine the length of #20-7 cable needed, add 10 inches, then cut. For example, if a five foot length of cable is needed, add 10 inches and cut the cable 5 foot 10 inches long.

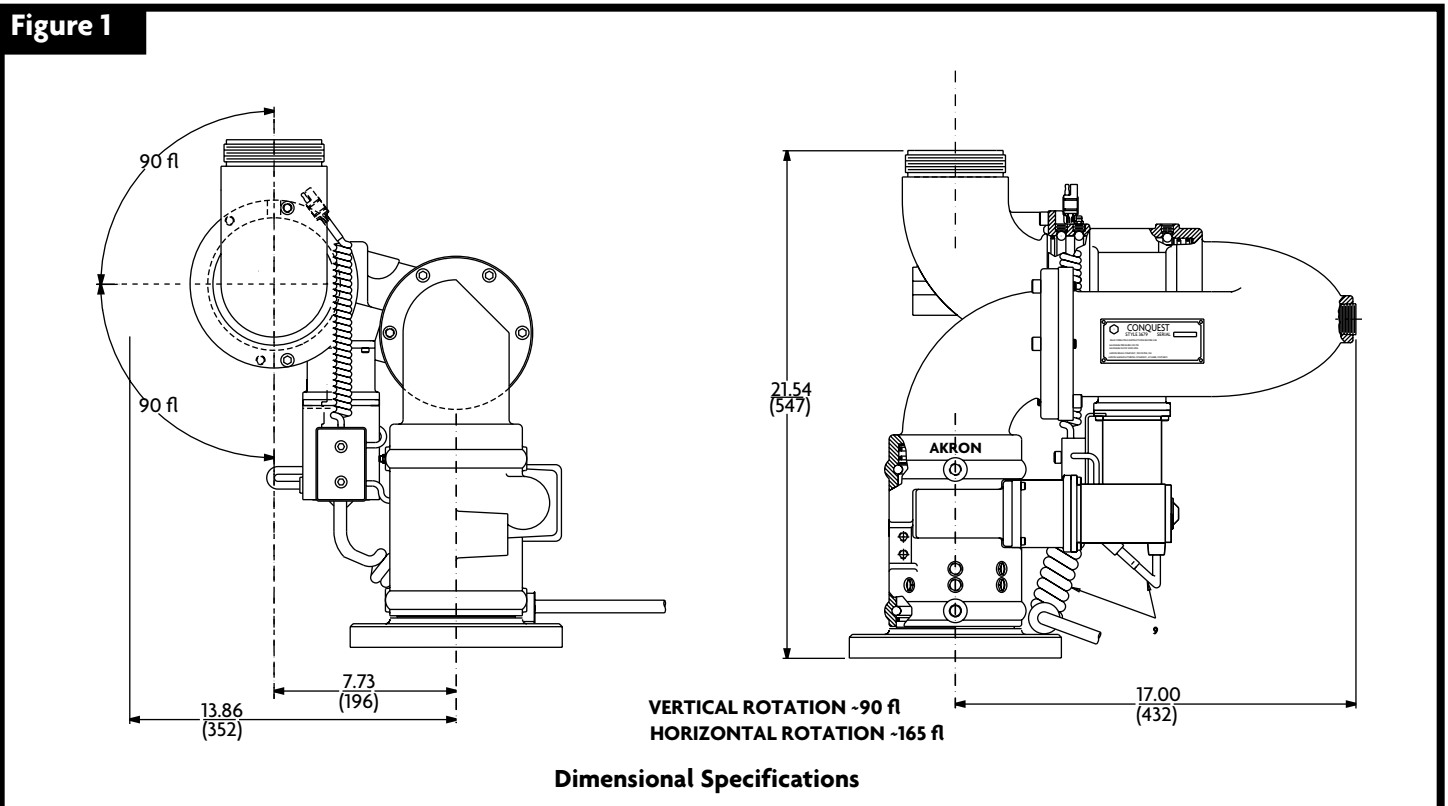

STEP 3 Remove the cable grip nut from the control box and put it on the cable with the threads facing out. On the same end of the cable remove 4 inches of the outer casing of the cable and strip back $\frac{3}{8}$ inch from each of the 7 wires.

STEP 4 Remove the four control box cover screws and set the control box cover aside. Thread the 7 wires through the cable grip nut attached to the control box and attach them to the proper terminals. Reattach control box cover and secure with the four screws.

STEP 5 Remove the cable grip nut from the plastic bag and put it on the other end of the cable with the threads facing out. Remove 6 inches of the outer cover and strip back $\frac{3}{8}$ inch from each of the 7 wires.

STEP 6 Remove the 6 logic box cover screws and set the logic box cover aside. Thread the 7 wires through the upper or lower control hole in the logic box (see component layout, Figure 3). Thread the cable grip washer and cable grip nut with the threads facing the box on the cable. Pull enough cable through the cable grip to ensure a good fit. Tighten the cable grip nut and attach the individual wires to the proper terminals (see wiring schematic Figure 2). Reattach the logic box cover and secure with the 6 screws.

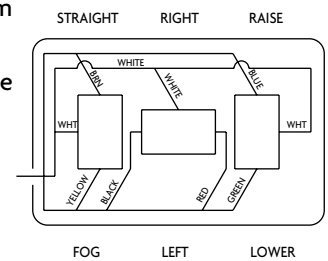

NOTE: The lower control and upper control wires must be attached to the correct terminals for the lower control to override the upper control. None of the functions can be controlled from the upper control box when any of the switches on the lower control box are activated.

MONITOR ATTACHMENT

These instructions are to attach the monitor wiring harness to the logic box.

STEP 7 Remove the cable grip nut for the wiring harness cable from the logic box, **DO NOT REMOVE THE CABLE GRIP**. Thread the cable grip nut on the wiring harness (#16-6) cable with the threads facing out. Thread the cable through the correct logic box cable grip (see component layout, Figure 3) so the cable grip nut will grab the outer cover of the cable. Tighten the cable grip nut and attach the individual wires to the proper terminals (see wiring schematic Figure 2). Reattach the logic box cover and secure with the 6 screws.

BATTERY ATTACHMENT

The battery connections should be the last connection made.

STEP 8 **AUXILIARY BATTERY**—Remove the logic box cable grip nut for the auxiliary battery and thread on the battery (#16-2) cable with the threads facing out. Thread the cable through the cable grip nut until the cable grip will grab the cable. Tighten the cable grip and attach the individual wires to the proper terminals (see wiring schematic Figure 2). Reattach the logic box cover and secure with the 6 screws.

STEP 9 **VEHICLE BATTERY**—Remove the logic box cable grip nut for the vehicle battery and thread on the battery (#16-2) cable with the threads facing out. Thread the cable through the cable grip until the cable grip nut will grab the cable. Tighten the cable grip nut and attach the individual wires to the proper terminals (see wiring schematic Figure 2).

MECHANICAL MONITOR ATTACHMENT

The Monitor is to be mounted on the waterway with eight $\frac{5}{8}$ inch bolts and nuts of grade five minimum and suitable washers with a minimum of six threads engagement. The notch on the side of the inlet flange (Figure 4) is the front of the monitor. The bolts must be tightened in a criss cross pattern progressively increasing tightening torque to a maximum of 100 pound feet dry.

THE ROTATIONAL STOPS SET THE BOUNDARIES FOR THE AREA IN WHICH THE MONITOR IS ALLOWED TO TRAVEL. The upper row controls the right travel, and the lower row controls the left travel. The angles for the rotational stops are with respect to the “reference direction” illustrated in Figure 4. The monitor is shipped with the upper row stop at point 7 which stops the monitor at 90° right, clockwise and the lower row stop at point 3 which stops the monitor at 90° left, counterclockwise. All other positions are achieved by switching the factory set stop and the plug in the desired stop location. Both the stops and the plugs have a $\frac{1}{2}$ inch hex head. Refer to Figure 4 to determine which stop location is needed for the desired right, clockwise or left, counterclockwise rotation. The elevation stop sets the upper limit of the elevation. The monitor is shipped with elevation stops at 90° above horizontal and 90° below horizontal. Other vertical positions are achieved by switching the $\frac{3}{8}$ socket head stops to the desired locations. The other 2 stop locations are 45° above horizontal and 70° below horizontal (Figure 5).

Figure 2

WIRING SCHEMATIC

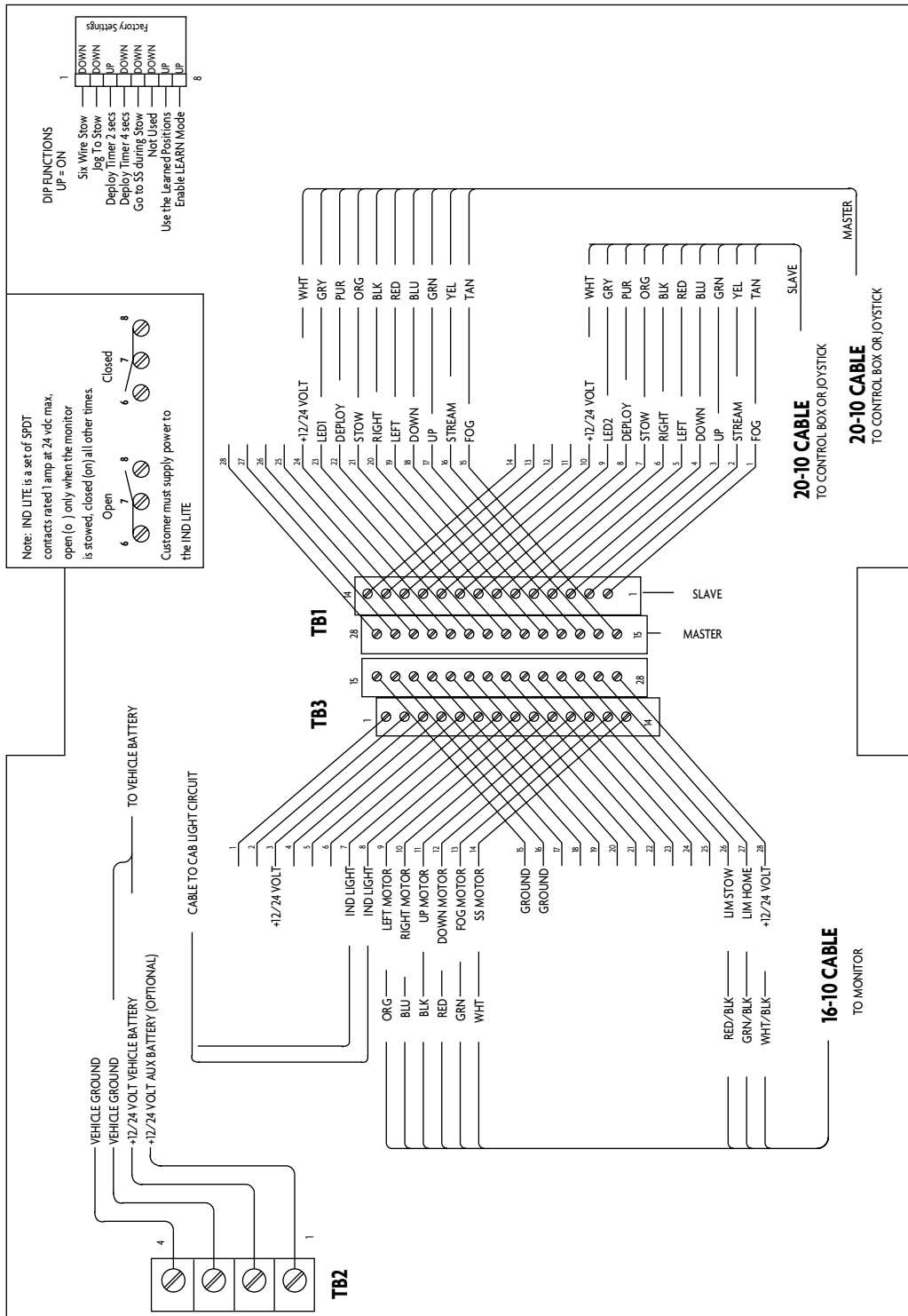

Figure 3

ELECTRICAL COMPONENT LAYOUT

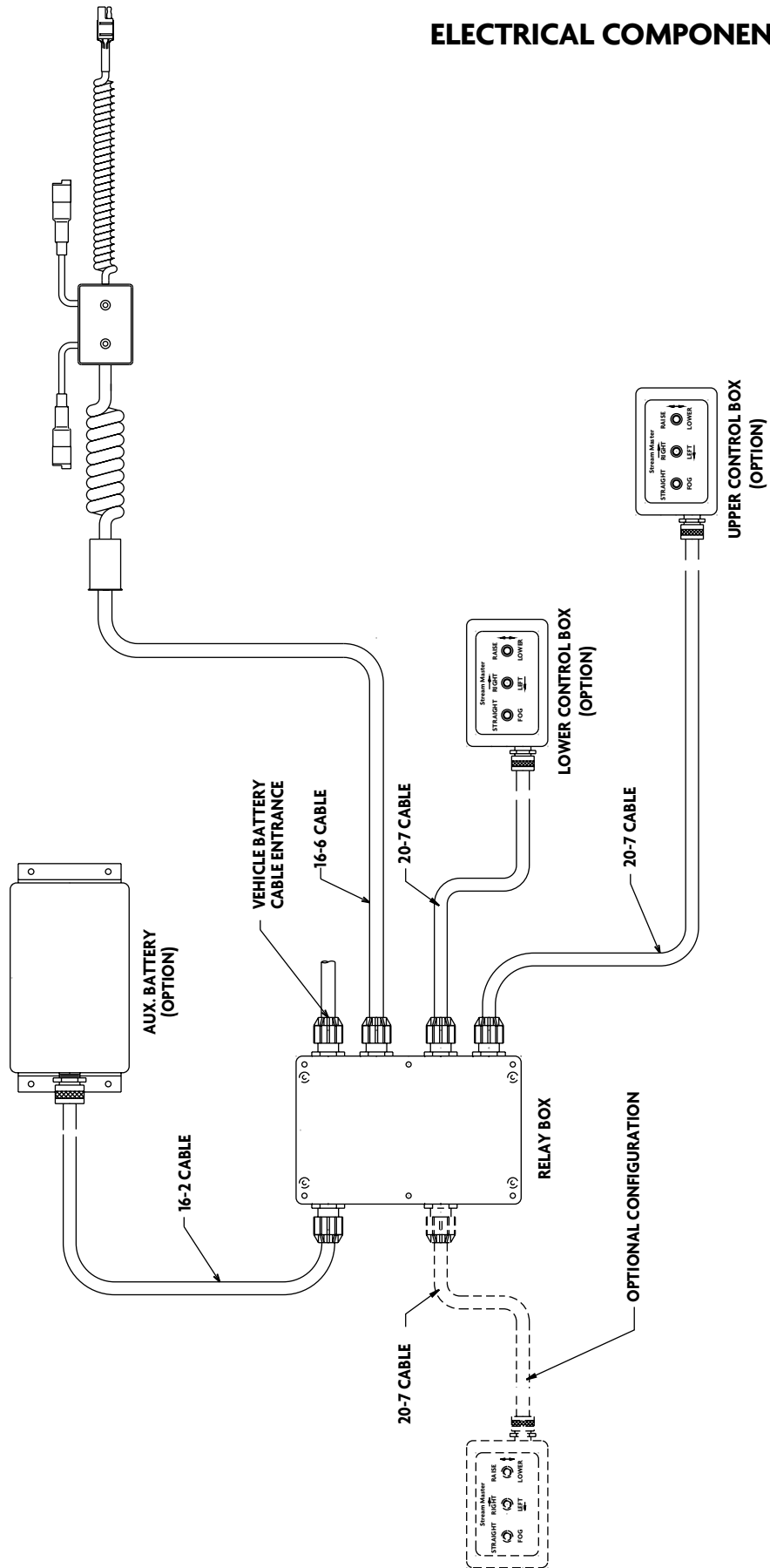
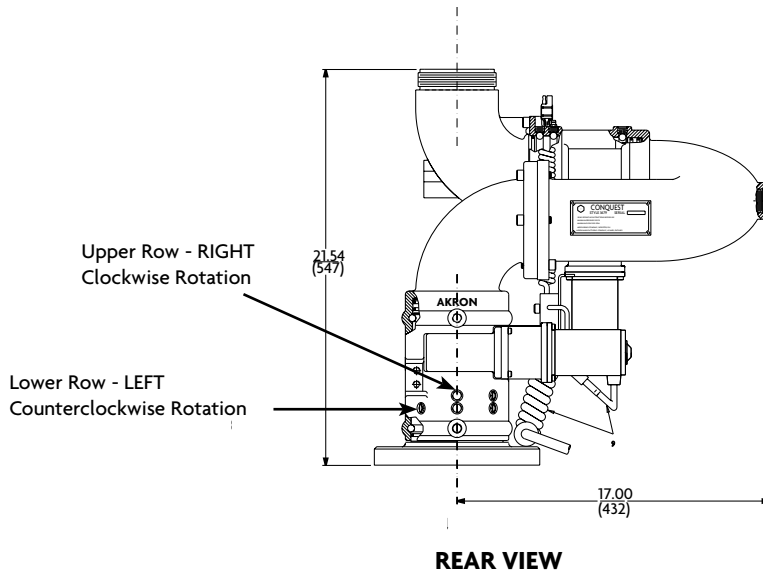
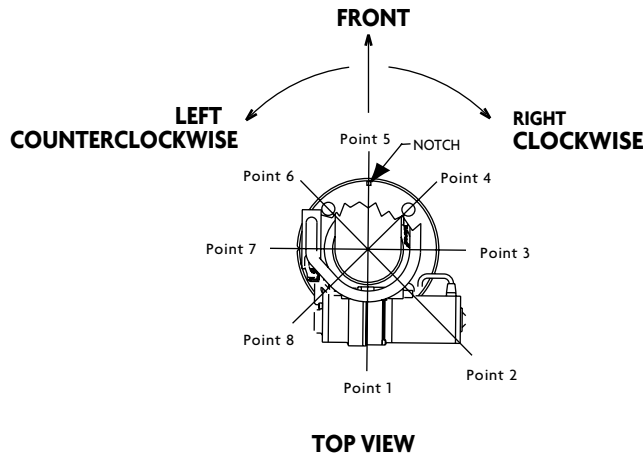

Figure 4

ROTATIONAL STOP LOCATIONS



**CONQUEST
ROTATION FOR EACH STOP COMBINATION**

		Upper Row							
Lower Row	CCW / CW	1	2	3	4	5	6	7	NO STOP
	1	165 / 165	120 / 165	75 / 165	30 / 165	180 / 0	180 / 45	180 / 90	180 / 165
	2	135 / 180	120 / 210	75 / 210	30 / 210	135 / 0	135 / 45	135 / 90	135 / 210
	3	90 / 180	90 / 225	75 / 255	30 / 255	90 / 0	90 / 45	90 / 90*	90 / 255
	4	45 / 180	45 / 225	45 / 270	30 / 300	45 / 0	45 / 45	45 / 90	45 / 300
	5	0 / 180	0 / 225	0 / 270	0 / 315	0 / 0	0 / 45	0 / 90	0 / 345
	6	165 / 30	120 / 30	75 / 30	30 / 30	315 / 0	300 / 30	255 / 30	315 / 30
	7	165 / 75	120 / 75	75 / 75	30 / 75	270 / 0	270 / 45	255 / 75	270 / 75
	8	165 / 120	120 / 120	75 / 120	30 / 120	210 / 0	210 / 45	210 / 90	210 / 135
NO STOP	165 / 180	120 / 225	75 / 270	30 / 315	345 / 0	300 / 45	255 / 90	N/A	

*Factory set stops

Note: There is no upper row for point 8 due to the location of the wiring harness.

OPERATING INSTRUCTIONS

UPPER AND LOWER CONTROL OPERATION

The upper and lower control boxes are used to control the monitor and nozzle. To change the nozzle pattern toward the “straight stream” or “fog” position press the proper toggle switch toward “STRAIGHT” or “FOG” respectively. To change the horizontal monitor position toward the “RIGHT” or “LEFT” press the proper toggle switch toward “RIGHT” or “LEFT” respectively. To change the vertical monitor position upward or downward press the proper toggle switch toward “RAISE” or “LOWER” respectively.

THE LOWER CONTROL BOX FUNCTIONS WILL OVERRIDE THE UPPER CONTROL BOX FUNCTIONS IN COMPLIANCE WITH THE REQUIREMENTS OF THE NFPA STANDARD. NOTE: THE LOWER CONTROL AND UPPER CONTROL WIRES MUST BE ATTACHED TO THE CORRECT TERMINALS FOR THE LOWER CONTROL TO OVERRIDE THE UPPER CONTROL. NONE OF THE FUNCTIONS CAN BE CONTROLLED FROM THE UPPER CONTROL BOX WHEN ANY OF THE SWITCHES ON THE LOWER CONTROL BOX ARE ACTIVATED.

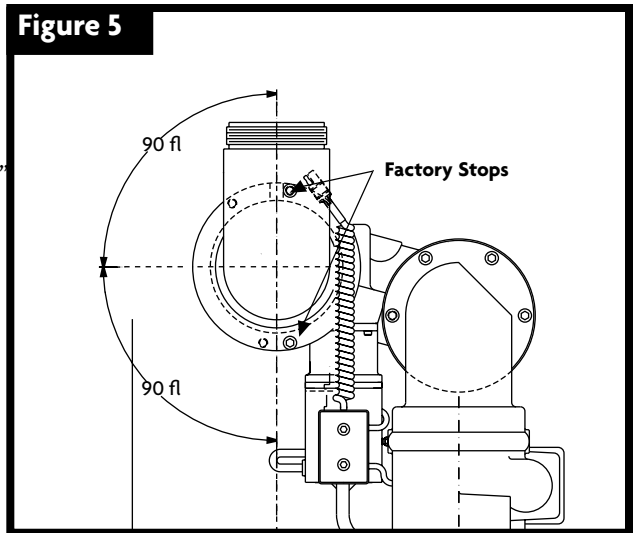

MANUAL OVERRIDE CONTROLS

THE MANUAL OVERRIDE CONTROL IS TO BE USED WHEN THE POWER TO THE MONITOR IS OFF. An override crank is attached. The crank is $\frac{1}{4}$ inch in size. A $\frac{1}{4}$ inch Allen wrench will also actuate the overrides. To operate the manual override, insert the hex head end of the override crank in the hexagon shaped hole. Then rotate or spin the override crank either clockwise or counterclockwise to aim the monitor in the desired direction.

WHEN THE OVERRIDE CRANKS ARE NO LONGER IN USE PUT THEM BACK IN THE STORAGE POSITION. DO NOT USE THE ELECTRIC CONTROLS WHEN THE OVERRIDE CRANKS ARE BEING USED OR ARE IN POSITION FOR USE.

MAINTENANCE INSTRUCTIONS

Your Conquest monitor and nozzle should be inspected prior to and after each use, to ensure it is in good operating condition. Periodically, an unanticipated incident occurs where the Conquest is misused in a manner that is inconsistent with standard operating practices and those listed in IFSTA. A partial list of potential misuse includes:

- Operating above maximum rated pressure and flow.
- Not draining, and allowing water to freeze inside.
- Prolonged exposure to temperatures above 130°F, or below -25°F.
- Having the Conquest nozzle hit a fixed object during operating or transportation.
- Other misuse that might be unique to your specific environment.

Also there are many “tell tale” signs that indicate repair is in order, such as:

- Controls that are either inoperable or difficult to operate.
- Excessive wear.
- Poor discharge performance.
- Water leaks.

If any of the above situations are encountered, the Conquest should be taken out of service, repaired, and tested by a qualified technician before placing it back in service.



PHONE: 330.264.5678 or 800.228.1161 | FAX: 330.264.2944 or 800.531.7335 | akronbrass.com

REVISED: 12/16

WARRANTY AND DISCLAIMER: We warrant Akron Brass products for a period of five (5) years after purchase against defects in materials or workmanship. Akron Brass will repair or replace product which fails to satisfy this warranty. Repair or replacement shall be at the discretion of Akron Brass. Products must be promptly returned to Akron Brass for warranty service.

We will not be responsible for: wear and tear; any improper installation, use, maintenance or storage; negligence of the owner or user; repair or modification after delivery; damage; failure to follow our instructions or recommendations; or anything else beyond our control. WE MAKE NO WARRANTIES, EXPRESS OR IMPLIED, OTHER THAN THOSE INCLUDED IN THIS WARRANTY STATEMENT, AND WE DISCLAIM ANY IMPLIED WARRANTY OF MERCHANTABILITY OR FITNESS FOR ANY PARTICULAR PURPOSE. Further, we will not be responsible for any consequential, incidental or indirect damages (including, but not limited to, any loss of profits) from any cause whatsoever. No person has authority to change this warranty.

© Akron Brass Company. 2011 All rights reserved. No portion of this can be reproduced without the express written consent of Akron Brass Company.